

ET9420/9421/9422 and ET9320/9321/9322

Absolute Maximum Ratings

Voltage at Any Pin	-0.3V to +7V	Package Power Dissipation	750 mW at 25°C
Operating Temperature Range		24 and 28 pin	400 mW at 70°C
ET9420/9421/9422	0°C to 70°C		250 mW at 85°C
ET9320/9321/9322	-40°C to +85°C	Package Power Dissipation	650 mW at 25°C
Storage Temperature Range	-65°C to +150°C	20 pin	300 mW at 70°C
Total Sink Current	75 mA		200 mW at 85°C
Total Source Current	95 mA	Lead Temperature (soldering, 10 sec.)	300°C

Absolute maximum ratings indicate limits beyond which damage to the device may occur. DC and AC electrical specifications are not ensured when operating the device at absolute maximum ratings.

ET9420/9421/9422

DC Electrical Characteristics $0^{\circ}\text{C} \leq T_A \leq 70^{\circ}\text{C}$, $4.5\text{V} \leq V_{CC} \leq 6.3\text{V}$ unless otherwise noted.

Parameter	Conditions	Min.	Max.	Units
Operation Voltage		4.5	6.3	V
Power Supply Ripple	Peak to Peak (Note 3)		0.4	V
Supply Current	Outputs Open		38	mA
Supply Current	Outputs Open, $V_{CC} = 5\text{V}$, $T_A = 25^{\circ}\text{C}$		30	mA
Input Voltage Levels				
CKI Input Levels				
Crystal Input				
Logic High	$V_{CC} = \text{Max.}$	3.0		V
Logic High	$V_{CC} = 5\text{V} \pm 5\%$	2.0		V
Logic Low		-0.3	0.4	V
TTL Input	$V_{CC} = 5\text{V} \pm 5\%$			
Logic High		2.0		V
Logic Low		-0.3	0.8	V
Schmitt Trigger Inputs				
RESET, CKI ($\div 4$)				
Logic High		$0.7 V_{CC}$		V
Logic Low		-0.3	0.6	V
SO Input Level (Test Mode)		2.0	3.0	V
All Other Inputs				
Logic High	$V_{CC} = \text{Max.}$	3.0		V
Logic High	$V_{CC} = 5\text{V} \pm 5\%$	2.0		V
Logic Low		-0.3	0.8	V
Input Levels High Trip Option				
Logic High		3.6		V
Logic Low		-0.3	1.2	V
Input Load Source Current	$V_{CC} = 5\text{V}$, $V_{IN} = 0\text{V}$			
CKO		-4	-800	μA
All Others		-100	-800	μA
Input Capacitance			7	pF
Hi-Z Input Leakage	$V_{CC} = 5\text{V}$	-1	+1	μA
Output Voltage levels				
Standard Outputs				
TTL Operation	$V_{CC} = 5\text{V} \pm 5\%$			
Logic High	$I_{OH} = -100\mu\text{A}$	2.4		V
Logic Low	$I_{OL} = 1.6\text{mA}$	-0.3	0.4	V
CMOS Operation				
Logic High	$I_{OH} = -10\mu\text{A}$	$V_{CC} - 1$		V

ET9420/9421/9422

DC Electrical Characteristics (Cont'd) $0^{\circ}\text{C} \leq T_A \leq 70^{\circ}\text{C}$, $4.5\text{V} \leq V_{CC} \leq 6.3\text{V}$ unless otherwise noted.

Parameter	Conditions	Min.	Max.	Units
Output Current Levels				
LED Direct Drive Output	$V_{CC} = 6\text{V}$			
Logic High	$V_{OH} = 2.0\text{V}$	2.5	14	mA
CKI Sink Current (R/C Option)	$V_{IN} = 3.5\text{V}$	2		mA
CKO (RAM Supply Current)	$V_R = 3.3\text{V}$		3	mA
TRI-STATE® or Open Drain Leakage Current	$V_{CC} = 5\text{V}$	-2.5	+2.5	μA
Output Current Levels				
Output Sink Current (I_{OL})	$V_{CC} = 6.3\text{V}$, $V_{OL} = 0.4\text{V}$	-2.0		mA
	$V_{CC} = 4.5\text{V}$, $V_{OL} = 0.4\text{V}$	-1.0		mA
Output Source Current (I_{OH})				
Standard Configuration				
All Outputs	$V_{CC} = 6.3\text{V}$, $V_{OH} = 3.0\text{V}$	-200	-900	μA
	$V_{CC} = 4.5\text{V}$, $V_{OH} = 2.0\text{V}$	-100	-500	μA
Push-Pull Configuration				
SO, SK Outputs	$V_{CC} = 6.3\text{V}$, $V_{OH} = 3.0\text{V}$	-1.0		mA
	$V_{CC} = 4.5\text{V}$, $V_{OH} = 2.0\text{V}$	-0.4		mA
TRI-STATE Configuration				
L ₀ -L ₇ Outputs	$V_{CC} = 6.3\text{V}$, $V_{OH} = 3.0\text{V}$	-2.0		mA
	$V_{CC} = 4.5\text{V}$, $V_{OH} = 2.0\text{V}$	-0.8		mA
LED Configuration				
L ₀ -L ₇ Outputs	$V_{CC} = 6.3\text{V}$, $V_{OH} = 3.0\text{V}$	-1.0		mA
	$V_{CC} = 4.5\text{V}$, $V_{OH} = 2.0\text{V}$	-0.5		mA
Allowable Sink Current				
Per Pin (L, D, G)			10	mA
Per Pin (All Others)			2	mA
Per Port (L)			16	mA
Per Port (D, G)			10	mA
Allowable Source Current				
Per Pin (L)			-15	mA
Per Pin (All Others)			-1.5	mA

ET9320/9321/9322

DC Electrical Characteristics $-40^{\circ}\text{C} \leq T_A \leq +85^{\circ}\text{C}$, $4.5\text{V} \leq V_{CC} \leq 5.5\text{V}$ unless otherwise noted.

Parameter	Conditions	Min.	Max.	Units
Operation Voltage		4.5	5.5	V
Power Supply Ripple	Peak to Peak (Note 3)		0.4	V
Supply Current	$T_A = -40^{\circ}\text{C}$, Outputs Open		40	mA
Input Voltage Levels				
CKI Input Levels				
Crystal Input				
Logic High		2.2		V
Logic Low		-0.3	0.3	V
TTL Input	$V_{CC} = 5\text{V} \pm 5\%$			
Logic High		2.2		V
Logic Low		-0.3	0.6	V
Schmitt Trigger Inputs				
RESET, CKI ($\div 4$)				
Logic High		$0.7V_{CC}$		V
Logic Low		-0.3	0.4	V
SO Input Level (Test Mode)		2.0	3.0	V
All Other Inputs				
Logic High	$V_{CC} = \text{Max.}$	3.0		V
Logic High	$V_{CC} = 5\text{V} \pm 5\%$	2.2		V
Logic Low		-0.3	0.6	V
Input Levels High Trip Option				
Logic High		3.6		V
Logic Low		-0.3	1.2	V
Input Load Source Current	$V_{CC} = 5\text{V}$, $V_{IN} = 0\text{V}$			
CKO		-4	-800	μA
All Others		-100	-800	μA
Input Capacitance			7	pF
Hi-Z Input Leakage	$V_{CC} = 5\text{V}$	-2	+2	μA
Output Voltage levels				
Standard Outputs				
TTL Operation	$V_{CC} = 5\text{V} \pm 5\%$			
Logic High	$I_{OH} = -75\mu\text{A}$	2.4		V
Logic Low	$I_{OL} = 1.6\text{mA}$	-0.3	0.4	V
CMOS Operation				
Logic High	$I_{OH} = -10\mu\text{A}$	$V_{CC} - 1$		V
Logic Low	$I_{OL} = 10\mu\text{A}$	-0.3	0.2	V
Output Current Levels				
LED Direct Drive Output	$V_{CC} = 5\text{V}$ (Note 4)			
Logic High	$V_{OH} = 2.0\text{V}$	1.0	12	mA
CKI Sink Current (R/C Option)	$V_{IN} = 3.5\text{V}$	2		mA
CKO (RAM Supply Current)	$V_R = 3.3\text{V}$		4	mA
TRI-STATE [®] or Open Drain Leakage Current	$V_{CC} = 5\text{V}$	-5	+5	μA
Allowable Sink Current				
Per Pin (L, D, G)			10	mA
Per Pin (All Others)			2	mA
Per Port (L)			16	mA
Per Port (D, G)			10	mA
Allowable Source Current				
Per Pin (L)			-15	mA
Per Pin (All Others)			-1.5	mA

AC Electrical Characteristics

ET9420/9421/9422
ET9320/9321/9322

$0^{\circ}\text{C} \leq T_A \leq 70^{\circ}\text{C}$, $4.5\text{V} \leq V_{CC} \leq 6.3\text{V}$ unless otherwise noted.
 $-40^{\circ}\text{C} \leq T_A \leq +85^{\circ}\text{C}$, $4.5\text{V} \leq V_{CC} \leq 5.5\text{V}$ unless otherwise noted.

Parameter	Conditions	Min.	Max.	Units
Instruction Cycle Time		4	10	μs
Operating CKI Frequency	$\div 16$ mode	1.6	4.0	MHz
	$\div 8$ mode	0.8	2.0	MHz
CKI Duty Cycle (Note 1)		40	60	%
Rise Time	Freq. = 4 MHz		60	ns
Fall Time	Freq. = 4 MHz		40	ns
CKI Using RC (Figure 8c)	$\div 4$ mode			
Frequency	$R = 15\text{k}\Omega \pm 5\%$, $C = 100\text{pF} \pm 10\%$	0.5	1.0	MHz
Instruction Cycle Time		4	8	μs
CKO as SYNC input (Figure 8d)				
t_{SYNC}	Figure 3a	50		ns
Inputs:				
SI				
t_{SETUP}		0.3		μs
t_{HOLD}		250		ns
All Other Inputs				
t_{SETUP}		1.7		μs
t_{HOLD}		300		ns
Output Propagation Delay	Test Conditions: $R_L = 5\text{k}\Omega$, $C_L = 50\text{pF}$, $V_{\text{OUT}} = 1.5\text{V}$	300		ns
SO and SK				
t_{pd1}			1.0	μs
t_{pd0}			1.0	μs
CKO				
t_{pd1}			0.25	μs
t_{pd0}			0.25	μs
All Other Outputs				
t_{pd1}			1.4	μs
t_{pd0}			1.4	μs
MICROBUS™ Timing	$C_L = 100\text{pF}$, $V_{CC} = 5\text{V} \pm 5\%$			
Read Operation (Figure 4)				
Chip Select Stable before $\overline{\text{RD}}$ — t_{CSR}		65		ns
Chip Select Hold Time for $\overline{\text{RD}}$ — t_{RCS}		20		ns
$\overline{\text{RD}}$ Pulse Width— t_{RR}		400		ns
Data Delay from $\overline{\text{RD}}$ — t_{RD}			375	ns
$\overline{\text{RD}}$ to Data Floating— t_{DF}			250	ns
Write Operation (Figure 5)				
Chip Select Stable before $\overline{\text{WR}}$ — t_{CSW}		65		ns
Chip Select Hold Time for $\overline{\text{WR}}$ — t_{WCS}		20		ns
$\overline{\text{WR}}$ Pulse Width— t_{WW}		400		ns
Data Set-Up Time for $\overline{\text{WR}}$ — t_{DW}		320		ns
Data Hold Time for $\overline{\text{WR}}$ — t_{WD}		100		ns
INTR Transition Time from $\overline{\text{WR}}$ — t_{WI}			700	ns

Note 1: Duty cycle = $t_{W1}/(t_{W1} + t_{W0})$.

Note 2: See Figure 9 for additional I/O characteristics.

Note 3: Voltage change must be less than 0.5 volts in a 1 ms period.

Note 4: Exercise great care not to exceed maximum device power dissipation limits when direct driving LEDs (or sourcing similar loads) at high temperature.

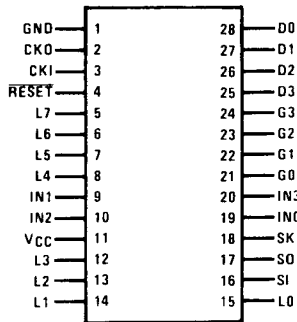

Order Number ET 9420/N ET 9320/N
Package N28A

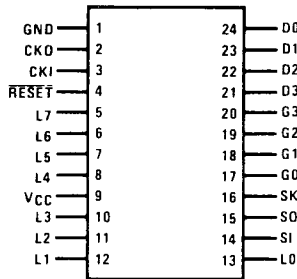

Order Number ET 9421/N, ET 9321/N
Package N24A

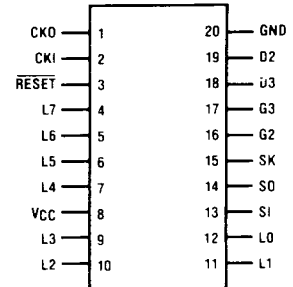

Order Number ET 9422/N ET 9322/N
Package N20A

Figure 2. Connection Diagrams

Pin	Description	Pin	Description
L7-L0	8 bidirectional I/O ports with TRI-STATE [®]	SK	Logic-controlled clock (or general purpose output)
G3-G0	4 bidirectional I/O ports	CKI	System oscillator input
D3-D0	4 general purpose outputs	CKO	System oscillator output (or general purpose input or RAM power supply)
IN3-IN0	4 general purpose inputs (COP420/320 only)	RESET	System reset input
S1	Serial input (or counter input)	VCC	Power supply
S0	Serial output (or general purpose output)	GND	Ground

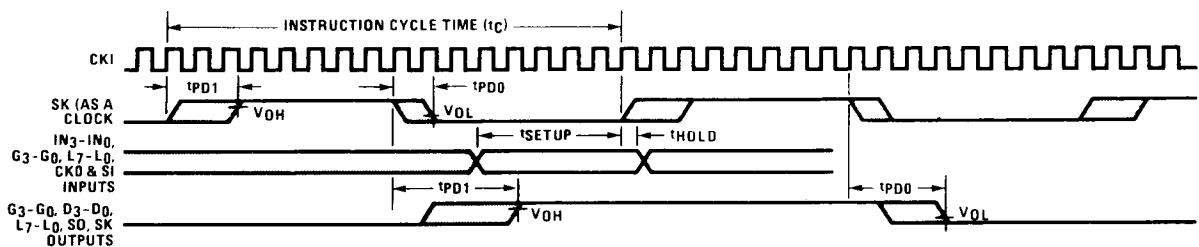

Figure 3. Input/Output Timing Diagrams (crystal divide by 16 mode)

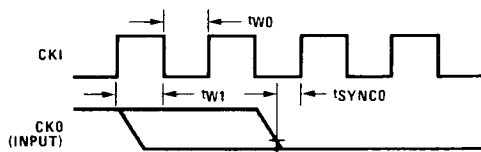

Figure 3A. Synchronization Timing

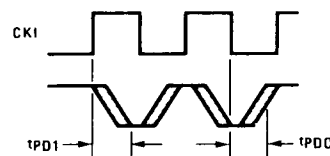

Figure 3B. CKO Output Timing

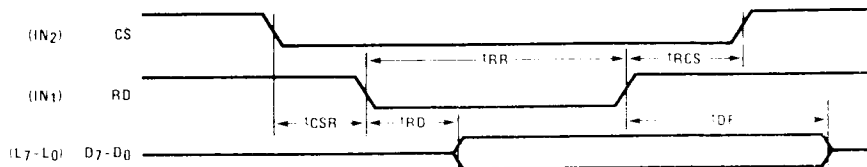

Figure 4. MICROBUS™ Read Operation Timing

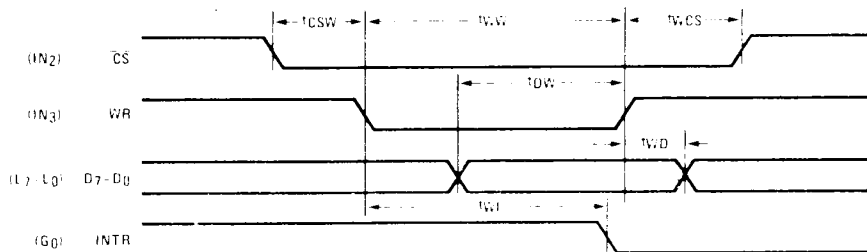

Figure 5. MICROBUS™ Write Operation Timing

Functional Description ET9420/9421/9422, ET9320/9321/9322

For ease of reading this description, only ET9420 and/or ET9421 are referenced; however, all such references apply equally to the ET9422, 9322, 9320 and/or ET9321, respectively.

A block diagram of the ET9420 is given in figure 1. Data paths are illustrated in simplified form to depict how the various logic elements communicate with each other in implementing the instruction set of the device. Positive logic is used. When a bit is set, it is a logic "1" (greater than 2 volts). When a bit is reset, it is a logic "0" (less than 0.8 volts).

Program Memory

Program Memory consists of a 1,024 byte ROM. As can be seen by an examination of the ET9420/9421 instruction set, these words may be program instructions, program data or ROM addressing data. Because of the special characteristics associated with the JP, JSRP, JID and LQID instructions, ROM must often be thought of as being organized into 16 pages of 64 words each.

ROM addressing is accomplished by a 10-bit PC register. Its binary value selects one of the 1,024 8-bit words contained in ROM. A new address is loaded into the PC register during each instruction cycle. Unless the instruction is a transfer of control instruction, the PC register is loaded with the next sequential 10-bit binary count value. Three levels of subroutine nesting are implemented by the 10-bit subroutine save registers, SA, SB and SC, providing a last-in, first-out (LIFO) hardware subroutine stack.

ROM instruction words are fetched, decoded and executed by the Instruction Decode, Control and Skip Logic circuitry.

Data Memory

Data memory consists of a 256-bit RAM, organized as 4 data registers of 16 4-bit digits. RAM addressing is implemented by a 6-bit **B register** whose upper 2 bits (Br) select 1 of 4 data registers and lower 4 bits (Bd) select 1

of 16 4-bit digits in the selected data register. While the 4-bit contents of the selected RAM digit (M) is usually loaded into or from, or exchanged with, the A register (accumulator), it may also be loaded into or from the Q latches or loaded from the L ports. RAM addressing may also be performed directly by the LDD and XAD instructions based upon the 6-bit contents of the operand field of these instructions. The Bd register also serves as a source register for 4-bit data sent directly to the D outputs.

Internal Logic

The 4-bit **A register** (accumulator) is the source and destination register for most I/O, arithmetic, logic and data memory access operations. It can also be used to load the Br and Bd portions of the B register, to load and input 4 bits of the 8-bit Q latch data, to input 4 bits of the 8-bit L I/O port data and to perform data exchanges with the SIO register.

A **4-bit adder** performs the arithmetic and logic functions of the ET9420/9421, storing its results in A. It also outputs a carry bit to the 1-bit **C register**, most often employed to indicate arithmetic overflow. The C register, in conjunction with the XAS instruction and the EN register, also serves to control the SK output. C can be outputted directly to SK or can enable SK to be a sync clock each instruction cycle time. (See XAS instruction and EN register description, below.)

Four **general-purpose inputs**, IN₃-IN₀, are provided; IN₁, IN₂ and IN₃ may be selected, by a mask-programmable option, as Read Strobe, Chip Select and Write Strobe inputs, respectively, for use in MICROBUS™ applications.

The **D register** provides 4 general-purpose outputs and is used as the destination register for the 4-bit contents of Bd.

The **G register** contents are outputs to 4 general-purpose bidirectional I/O ports. G₀ may be mask-programmed as an output for MICROBUS™ applications.

The **Q register** is an internal, latched, 8-bit register, used to hold data loaded to or from M and A, as well as 8-bit data from ROM. Its contents are output to the L I/O ports when the L drivers are enabled under program control. (See LEI instruction). With the MICROBUS™ option selected, Q can also be loaded with the 8-bit contents of the L I/O ports upon the occurrence of a write strobe from the host CPU.

The **8 L drivers**, when enabled, output the contents of latched Q data to the L I/O ports. Also, the contents of L may be read directly into A and M. As explained above, the MICROBUS™ option allows L I/O port data to be latched into the Q register. L I/O ports can be directly connected to the segments of a multiplexed LED display (using the LED Direct Drive output configuration option) with Q data being outputted to the Sa-Sg and decimal point segments of the display.

The **SIO register** functions as a 4-bit serial-in/serial-out shift register or as a binary counter depending on the contents of the EN register. (See EN register description, below.) Its contents can be exchanged with A, allowing it to input or output a continuous serial data stream. SIO may also be used to provide additional parallel I/O by connecting SO to external serial-in/parallel-out shift registers.

The XAS instruction copies C into the SKL latch. In the counter mode, SK is the output of SKL; in the shift register mode, SK outputs SKL ANDed with the clock.

The **EN register** is an internal 4-bit register loaded under program control by the LEI instruction. The state of each bit of this register selects or deselects the particular feature associated with each bit of the EN register (EN₃-EN₀).

1. The least significant bit of the enable register, EN₀, selects the SIO register as either a 4-bit shift register or a 4-bit binary counter. With EN₀ set, SIO is an asynchronous binary counter, *decrementing* its value by one upon each low-going pulse ("1" to "0") occurring on the SI input. Each pulse must be at least two instruction cycles wide. SK outputs the value of SKL. The SO output is equal to the value of EN₃. With EN₀ reset, SIO is a serial shift register shifting left each instruction cycle time. The data present at SI goes into the least significant bit of SIO. SO can be enabled to output the most significant bit of SIO each cycle time. (See 4 below.) The SK output becomes a logic-controlled clock.
2. With EN₁ set the IN₁ input is enabled as an interrupt input. Immediately following an interrupt, EN₁ is reset to disable further interrupts.
3. With EN₂ set, the L drivers are enabled to output the data in Q to the L I/O ports. Resetting EN₂ disables the L drivers, placing the L I/O ports in a high-impedance input state.
4. EN₃, in conjunction with EN₀, affects the SO output. With EN₀ set (binary counter option selected) SO will output the value loaded into EN₃. With EN₀ reset (serial shift register option selected), setting EN₃ enables SO as the output of the SIO shift register, outputting serial shifted data each instruction time. Resetting EN₃ with the serial shift register option selected disables SO as the shift register output; data continues to be shifted through SIO and can be exchanged with A via an XAS instruction but SO remains reset to "0." The table below provides a summary of the modes associated with EN₃ and EN₀.

Enable Register Modes — Bits EN₃ and EN₀

EN ₃	EN ₀	SIO	SI	SO	SK
0	0	Shift Register	Input to Shift Register	0	If SKL = 1, SK = CLOCK If SKL = 0, SK = 0
1	0	Shift Register	Input to Shift Register	Serial Out	If SKL = 1, SK = CLOCK If SKL = 0, SK = 0
0	1	Binary Counter	Input to Binary Counter	0	If SKL = 1, SK = 1 If SKL = 0, SK = 0
1	1	Binary Counter	Input to Binary Counter	1	If SKL = 1, SK = 1 If SKL = 0, SK = 0

Interrupt

The following features are associated with the IN_1 interrupt procedure and protocol and must be considered by the programmer when utilizing interrupts.

- The interrupt, once acknowledged as explained below, pushes the next sequential program counter address ($PC + 1$) onto the stack, pushing in turn the contents of the other subroutine-save registers to the next lower level ($PC + 1 \rightarrow SA \rightarrow SB \rightarrow SC$). Any previous contents of SC are lost. The program counter is set to hex address 0FF (the last word of page 3) and EN_1 is reset.
- An interrupt will be acknowledged only after the following conditions are met:
 - EN_1 has been set.
 - A low-going pulse ("1" to "0") at least two instruction cycles wide occurs on the IN_1 input.
 - A currently executing instruction has been completed.
 - All successive transfer of control instructions and successive LBIs have been completed (e.g., if the main program is executing a JP instruction which transfers program control to another JP instruction, the interrupt will not be acknowledged until the second JP instruction has been executed).
- Upon acknowledgement of an interrupt, the skip logic status is saved and later restored upon popping of the stack. For example, if an interrupt occurs during the execution of ASC (Add with Carry, Skip on Carry) instruction which results in carry, the skip logic status is saved and program control is transferred to the interrupt servicing routine at hex address 0FF. At the end of the interrupt routine, a RET instruction is executed to "pop" the stack and return program control to the instruction following the original ASC. At this time, the skip logic is enabled and skips this instruction because of the previous ASC carry. Subroutines and LQID instructions should not be nested within the interrupt service routine, since their popping the stack will enable any previously saved main program skips, interfering with the orderly execution of the interrupt routine.
- The first instruction of the interrupt routine at hex address 0FF must be a NOP.
- A LEI instruction can be put immediately before the RET to re-enable interrupts.

Microbus™ Interface

The ET9420 has an option which allows it to be used as a peripheral microprocessor device. Inputting and outputting data from and to a host microprocessor (μP). IN_1 , IN_2 and IN_3 general purpose inputs become **MICROBUS™ compatible** read-strobe, chip-select, and write-strobe lines, respectively. IN_1 becomes \overline{RD} — a logic "0" on this input will cause Q latch data to be enabled to the L ports for input to the μP . IN_2 becomes \overline{CS} — a logic "0" on this line selects the ET9420 as the μP peripheral device by enabling the operation of the \overline{RD} and \overline{WR} lines and allows for the selection of one of several peripheral components. IN_3 becomes \overline{WR} — a logic "0" on this line will write bus data from the L ports to the Q latches for input to the ET9420. G_0 becomes INTR a "ready" output, reset by a write pulse from the

μP on the \overline{WR} line, providing the "handshaking capability necessary for asynchronous data transfer between the host CPU and the ET9420.

This option has been designed for compatibility with National's MICROBUS™ — a standard interconnect system for 8-bit parallel data transfer between MOS/LSI CPUs and interfacing devices. (See MICROBUS™ National Publication.) The functioning and timing relationships between the ET9420 signal lines affected by this option are as specified for the MICROBUS™ interface, and are given in the AC electrical characteristics and shown in the timing diagrams (figures 4 and 5). Connection of the ET9420 to the MICROBUS™ is shown in Figure 6.

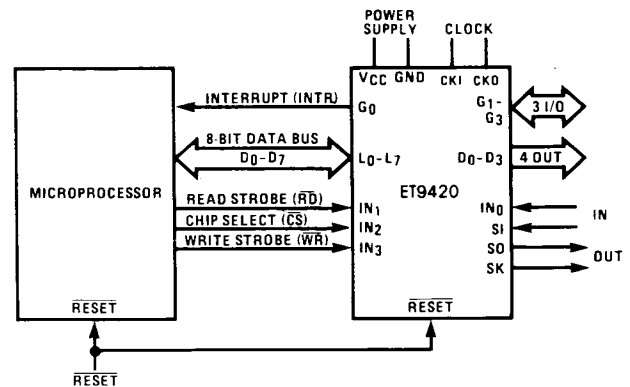

Figure 6. MICROBUS™ Option Interconnect

Initialization

The Reset Logic, internal to the ET9420/9421, will initialize (clear) the device upon power-up if the power supply rise time is less than 1ms and greater than $1\mu s$. If the power supply rise time is greater than 1ms, the user must provide an external RC network and diode to the \overline{RESET} pin as shown below. The \overline{RESET} pin is configured as a Schmitt trigger input. If not used it should be connected to V_{CC} . Initialization will occur whenever a logic "0" is applied to the \overline{RESET} input, provided it stays low for at least three instruction cycle times.

Upon initialization, the PC register is cleared to 0 (ROM address 0) and the A, B, C, D, EN, and G registers are cleared. The SK output is enabled as a SYNC output, providing a pulse each instruction cycle time. *Data Memory (RAM) is not cleared upon initialization.* The first instruction at address 0 must be a CLRA.

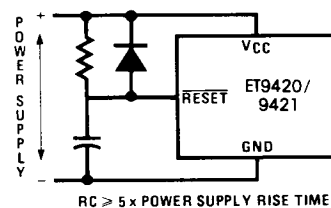

Figure 7. Power-Up Clear Circuit

Oscillator

There are four basic clock oscillator configurations available as shown by figure 8.

- Crystal Controlled Oscillator.** CKI and CKO are connected to an external crystal. The instruction cycle time equals the crystal frequency divided by 16 (optional by 8).
- External Oscillator.** CKI is an external clock input signal. The external frequency is divided by 16 (optional by 8) to give the instruction cycle time. CKO is now available to be used as the RAM power supply (V_R) or as a general purpose input.
- RC Controlled Oscillator.** CKI is configured as a single pin RC controlled Schmitt trigger oscillator. The instruction cycle equals the oscillation frequency divided by 4. CKO is available for non-timing functions.
- Externally Synchronized Oscillator.** Intended for use in multi-COP systems, CKO is programmed to function as an input connected to the SK output of another ET9420/9421 with CKI connected as shown. In this configuration, the SK output connected to CKO must provide a SYNC (instruction cycle) signal to CKO, thereby allowing synchronous data transfer between the COPs using only the SI and SO serial I/O pins in conjunction with the XAS instruction. Note that on power-up SK is automatically enabled as a SYNC output (See Functional Description, Initialization, above).

CKO Pin Options

In a crystal controlled oscillator system, CKO is used as an output to the crystal network. As an option CKO can be a SYNC input as described above. As another option CKO can be a general purpose input, read into bit 2 of A (accumulator) upon execution of an INIL instruction. As another option, CKO can be a RAM power supply pin (V_R), allowing its connection to a standby/backup power supply to maintain the integrity of RAM data with minimum power drain when the main supply is inoperative or shut down to conserve power. Using either option is appropriate in applications where the ET9420/9421 system timing configuration does not require use of the CKO pin.

RAM Keep-Alive Option (Not available on ET9422)

Selecting CKO as the RAM power supply (V_R) allows the user to shut off the chip power supply (V_{CC}) and maintain data in the RAM. To insure that RAM data integrity is maintained, the following conditions must be met:

- \overline{RESET} must go low before V_{CC} goes below spec during power off; V_{CC} must be within spec before \overline{RESET} goes high on power up.
- V_R must be within the operating range of the chip, and equal to $V_{CC} \pm 1V$ during normal operation.
- V_R must be $\geq 3.3V$ with V_{CC} off.

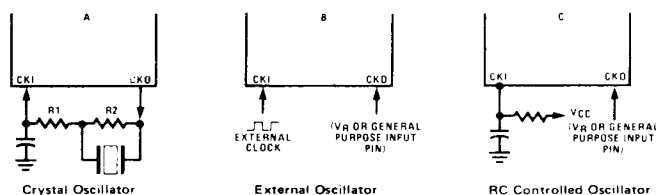

Crystal Oscillator

Crystal Value	Component Values		
	R1 (Ω)	R2 (Ω)	C (pF)
4 MHz	1k	1M	27
3.58 MHz	1k	1M	27
2.09 MHz	1k	1M	56

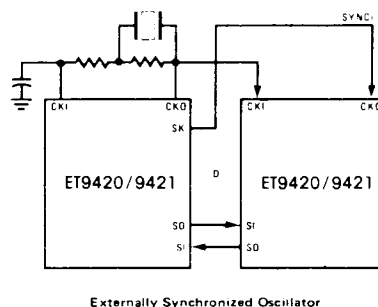

RC Controlled Oscillator

R (k Ω)	C (pF)	Instruction Cycle Time (μs)
12	100	$5 \pm 20\%$
6.8	220	$5.3 \pm 23\%$
8.2	300	$8 \pm 29\%$
22	100	$8.6 \pm 16\%$

Note: $50\text{ k}\Omega \geq R \geq 5\text{ k}\Omega$
 $360\text{ pF} \geq C \geq 50\text{ pF}$

Figure 8. ET9420/9421/ET9320/9321 Oscillator

I/O Options

ET9420/9421 outputs have the following optional configurations, illustrated in Figure 9a :

- a. Standard** — an enhancement mode device to ground in conjunction with a depletion-mode device to V_{CC} , compatible with TTL and CMOS input requirements. Available on SO, SK, and all D and G outputs.
- b. Open-Drain** — an enhancement-mode device to ground only, allowing external pull-up as required by the user's application. Available on SO, SK, and all D and G outputs.
- c. Push-Pull** — An enhancement-mode device to ground in conjunction with a depletion-mode device paralleled by an enhancement-mode device to V_{CC} . This configuration has been provided to allow for fast rise and fall times when driving capacitive loads. Available on SO and SK outputs only.
- d. Standard L** — same as **a.**, but may be disabled. Available on L outputs only.
- e. Open Drain L** — same as **b.**, but may be disabled. Available on L outputs only.
- f. LED Direct Drive** — an enhancement-mode device to ground and to V_{CC} , meeting the typical current sourcing requirements of the segments of an LED display. The sourcing device is clamped to limit current flow. These devices may be turned off under program control (See Functional Description, EN Register), placing the outputs in a high-impedance state to provide required LED segment blanking for a multiplexed display.
- g. TRI-STATE® Push-Pull** — an enhancement-mode device to ground and V_{CC} . These outputs are TRI-STATE outputs, allowing for connection of these outputs to a data bus shared by other bus drivers.

ET9420/9421 inputs have the following optional configurations :

- h.** An on-chip depletion load device to V_{CC} .
- i.** A Hi-Z input which must be driven to a "1" or "0" by external components.

The above input and output configurations share common enhancement-mode and depletion-mode devices. Specifically, all configurations use one or more of six devices (numbered 1-6, respectively). Minimum and maximum current (I_{OUT} and V_{OUT}) curves are given in Figure 9b for each of these devices to allow the designer to effectively use these I/O configurations in designing a ET9420/9421 system.

The SO, SK outputs can be configured as shown in **a.**, **b.**, or **c.** The D and G outputs can be configured as shown in **a.** or **b.** Note that when inputting data to the G ports, the G outputs should be set to "1." The L outputs can be configured as in **d.**, **e.**, **f.** or **g.**

An important point to remember if using configuration **d.** or **f.** with the L drivers is that even when the L drivers are disabled, the depletion load device will source a small amount of current (see Figure 9b, device 2); however, when the L lines are used as inputs, the disabled depletion device can *not* be relied on to source sufficient current to pull an input to logic "1".

ET9421

If the ET9420 is bonded as a 24-pin device, it becomes the ET9421, illustrated in Figure 2, ET9420/9421 Connection Diagrams. Note that the ET9421 does not contain the four general purpose IN inputs ($IN_3 - IN_0$). Use of this option precludes, of course, use of the IN options, interrupt feature, and the MICROBUS™ option which uses $IN_1 - IN_3$. All other options are available for the ET9421.

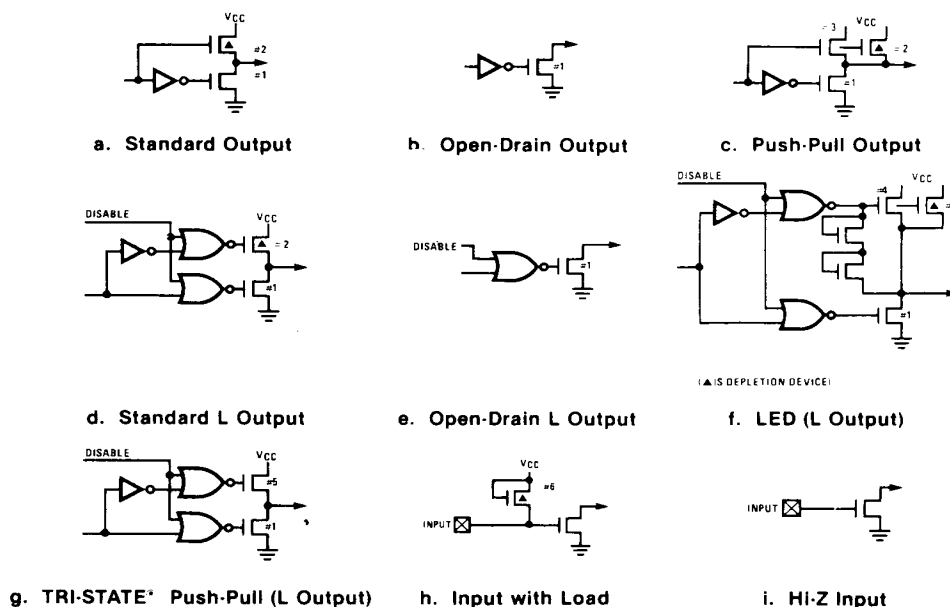

Figure 9a. Input/Output Configurations

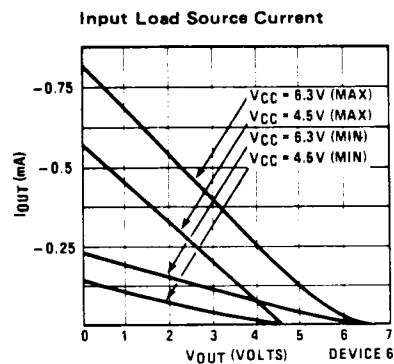
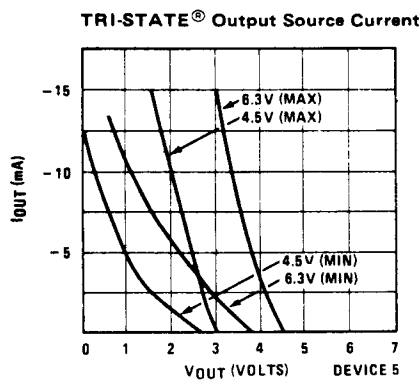
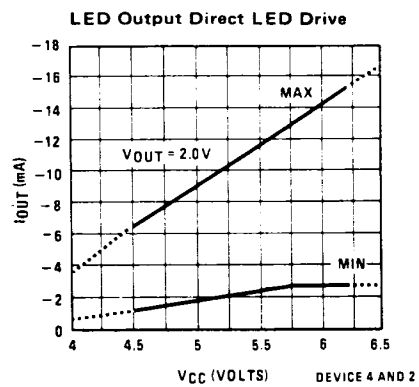
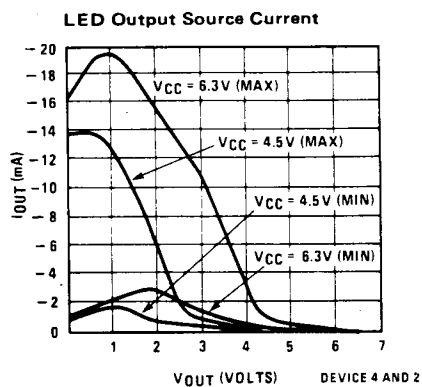
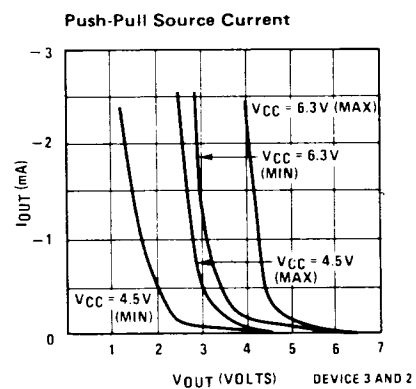
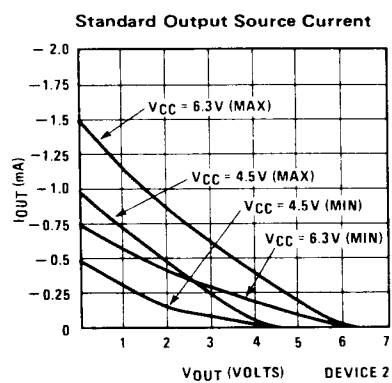
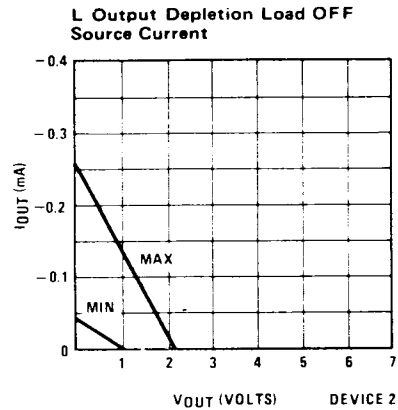
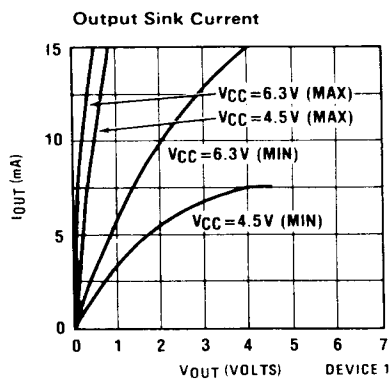

Figure 9b. ET9420/9421 Input/Output Characteristics

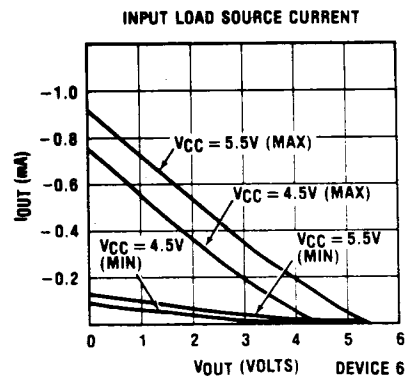
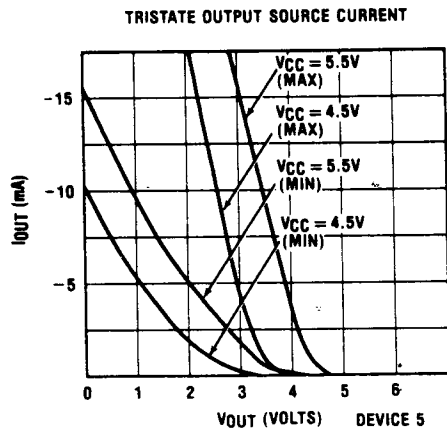
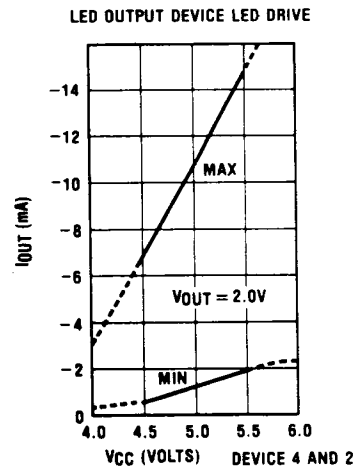
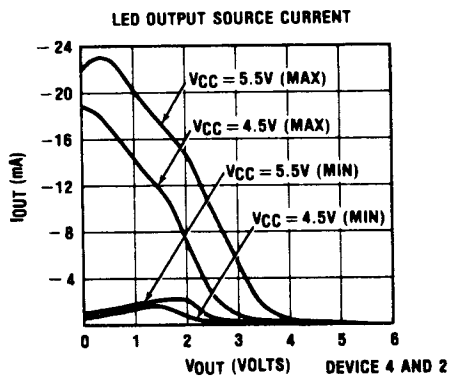
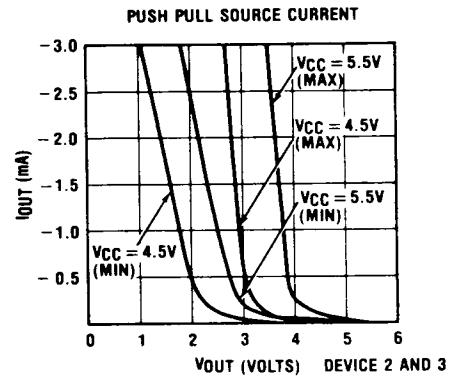
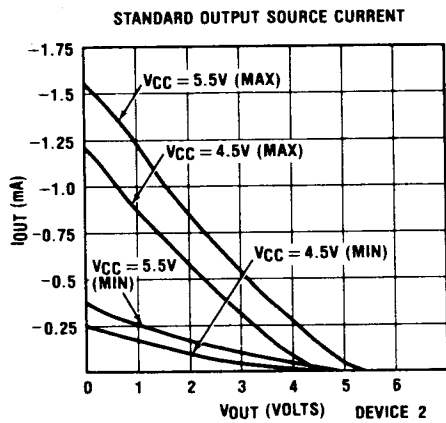
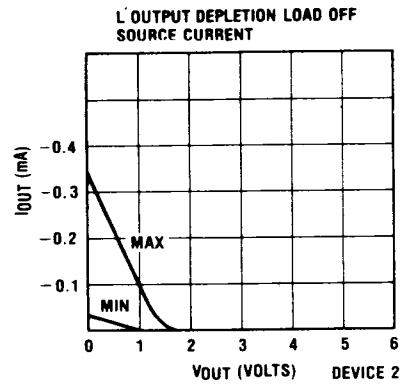
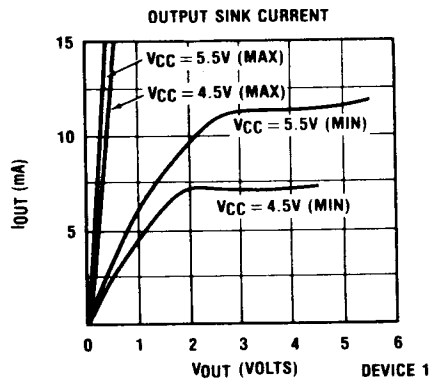

Figure 9c. ET9320/9321 Input/Output Characteristics

ET9420/9421/9422.ET9320/9321/9322 Instruction Set

Table 1 is a symbol table providing internal architecture, instruction operand and operational symbols used in the instruction set table.

Table 2 provides the mnemonic, operand, machine code, data flow, skip conditions, and description associated with each instruction in the ET9420/9421/9422 instruction set.

Table 2. ET9420/9421/9422.ET9320/9321/9322 Instruction Set Table Symbols

Symbol	Definition	Symbol	Definition
INTERNAL ARCHITECTURE SYMBOLS		INSTRUCTION OPERAND SYMBOLS	
A	4-bit Accumulator	d	4-bit Operand Field, 0-15 binary (RAM Digit Select)
B	6-bit RAM Address Register	r	2-bit Operand Field, 0-3 binary (RAM Register Select)
Br	Upper 2 bits of B (register address)	a	10-bit Operand Field, 0-1023 binary (ROM Address)
Bd	Lower 4 bits of B (digit address)	y	4-bit Operand Field, 0-15 binary (Immediate Data)
C	1-bit Carry Register	RAM(s)	Contents of RAM location addressed by s
D	4-bit Data Output Port	ROM(t)	Contents of ROM location addressed by t
EN	4-bit Enable Register	OPERATIONAL SYMBOLS	
G	4-bit Register to latch data for G I/O Port	+	Plus
IL	Two 1-bit latches associated with the IN ₃ or IN ₀ inputs	-	Minus
IN	4-bit Input Port	→	Replaces
L	8-bit TRI-STATE [®] I/O Port	↔	Is exchanged with
M	4-bit contents of RAM Memory pointed to by B Register	=	Is equal to
PC	10-bit ROM Address Register (program counter)	\bar{A}	The one's complement of A
Q	8-bit Register to latch data for L I/O Port	⊕	Exclusive-OR
SA	10-bit Subroutine Save Register A	:	Range of values
SB	10-bit Subroutine Save Register B		
SC	10-bit Subroutine Save Register A		
SIO	4-bit Shift Register and Counter		
SK	Logic-Controlled Clock Output		

Table 2. ET9420/9421/9422.ET9320/9321/9322 Instruction Set

Mnemonic	Operand	Hex Code	Machine Language Code (Binary)	Data Flow	Skip Conditions	Description
ARITHMETIC INSTRUCTIONS						
ASC		30	$\boxed{0011} \boxed{0000}$	$A + C + \text{RAM}(B) \rightarrow A$ Carry $\rightarrow C$	Carry	Add with Carry. Skip on Carry
ADD		31	$\boxed{0011} \boxed{0001}$	$A + \text{RAM}(B) \rightarrow A$	None	Add RAM to A
ADT		4A	$\boxed{0100} \boxed{1010}$	$A + 10_{10} \rightarrow A$	None	Add Ten to A
AISC	y	5-	$\boxed{0101} \boxed{y}$	$A + y \rightarrow A$	Carry	Add Immediate. Skip on Carry (y ≠ 0)
CASC		10	$\boxed{0001} \boxed{0000}$	$\bar{A} + \text{RAM}(B) + C \rightarrow A$ Carry $\rightarrow C$	Carry	Complement and Add with Carry. Skip on Carry
CLRA		00	$\boxed{0000} \boxed{0000}$	$0 \rightarrow A$	None	Clear A
COMP		40	$\boxed{0100} \boxed{0000}$	$\bar{A} \rightarrow A$	None	One's complement of A to A
NOP		44	$\boxed{0100} \boxed{0100}$	None	None	No Operation
RC		32	$\boxed{0011} \boxed{0010}$	"0" $\rightarrow C$	None	Reset C
SC		22	$\boxed{0010} \boxed{0010}$	"1" $\rightarrow C$	None	Set C
XOR		02	$\boxed{0000} \boxed{0010}$	$A \oplus \text{RAM}(B) \rightarrow A$	None	Exclusive-OR RAM with A

Table 2. ET9420/9421/9422.ET9320/9321/9322 Instruction Set (continued)

Mnemonic	Operand	Hex Code	Machine Language Code (Binary)	Data Flow	Skip Conditions	Description
TRANSFER OF CONTROL INSTRUCTIONS						
JID		FF	1111 1111	ROM (PC _{9:8} , A,M) → PC _{7:0}	None	Jump Indirect (Note 3)
JMP	a	6-	0110 00 a _{9:8}	a → PC	None	Jump
		--	a _{7:0}			
JP	a	--	1 a _{6:0}	a → PC _{6:0}	None	Jump within Page (Note 4)
			(pages 2,3 only)			
			or			
		--	11 a _{5:0}	a → PC _{5:0}		
			(all other pages)			
JSRP	a	--	10 a _{5:0}	PC+1 → SA → SB → SC 0010 → PC _{9:6} a → PC _{5:0}	None	Jump to Subroutine Page (Note 5)
JSR	a	6-	0110 10 a _{9:8}	PC+1 → SA → SB → SC	None	Jump to Subroutine
		--	a _{7:0}	a → PC		
RET		48	0100 1000	SC → SB → SA → PC	None	Return from Subroutine
RETSK		49	0100 1001	SC → SB → SA → PC	Always Skip on Return	Return from Subroutine then Skip
MEMORY REFERENCE INSTRUCTIONS						
CAMQ		33	0011 0011	A → Q _{7:4}	None	Copy A, RAM to Q
		3C	0011 1100	RAM(B) → Q _{3:0}		
CQMA		33	0011 0011	Q _{7:4} → RAM(B)	None	Copy Q to RAM, A
		2C	0010 1100	Q _{3:0} → A		
LD	r	-5	00 r 0101	RAM(B) → A Br ⊕ r → Br	None	Load RAM into A, Exclusive-OR Br with r
LDD	r,d	23	0010 0011	RAM(r,d) → A	None	Load A with RAM pointed to directly by r,d
		--	00 r d			
LQID		BF	1011 1111	ROM(PC _{9:8} ,A,M) → Q SB → SC	None	Load Q Indirect (Note 3)
RMB	0	4C	0100 1100	0 → RAM(B) ₀	None	Reset RAM Bit
	1	45	0100 0101	0 → RAM(B) ₁		
	2	42	0100 0010	0 → RAM(B) ₂		
	3	43	0100 0011	0 → RAM(B) ₃		
SMB	0	4D	0100 1101	1 → RAM(B) ₀	None	Set RAM Bit
	1	47	0100 1101	1 → RAM(B) ₁		
	2	46	0100 0110	1 → RAM(B) ₂		
	3	4B	0100 1011	1 → RAM(B) ₃		

Table 2. ET9420/9421/9422, ET9320/9321/9322 Instruction Set (continued)

Mnemonic	Operand	Hex Code	Machine Language Code (Binary)	Data Flow	Skip Conditions	Description
MEMORY REFERENCE INSTRUCTIONS (continued)						
STII	y	7-	0111 y	y → RAM(B) Bd + 1 → Bd	None	Store Memory Immediate and Increment Bd
X	r	-6	00 r 0110	RAM(B) ↔ A Br ⊕ r → Br	None	Exchange RAM with A, Exclusive-OR Br with r
XAD	r,d	23 --	0010 0011 10 r d	RAM(r,d) ↔ A	None	Exchange A with RAM pointed to directly by r,d
XDS	r	-7	00 r 0111	RAM(B) ↔ A Bd - 1 → Bd Br ⊕ r → Br	Bd decrements past 0	Exchange RAM with A and Decrement Bd, Exclusive-OR Br with r
XIS	r	-4	00 r 0100	RAM(B) ↔ A Bd + 1 → Bd Br ⊕ r → Br	Bd increments past 15	Exchange RAM with A and Increment Bd, Exclusive-OR Br with r
REGISTER REFERENCE INSTRUCTIONS						
CAB		50	0101 0000	A → Bd	None	Copy A to Bd
CBA		4E	0100 1110	Bd → A	None	Copy Bd to A
LBI	r,d	-- 33 --	00 r (d-1) (d = 0, 9:15) or 0011 0011 10 r d (any d)	r,d → B	Skip until not a LBI	Load B immediate with r,d (Note 6)
LEI	y	33 6-	0011 0011 0110 y	y → EN	None	Load EN Immediate (Note 7)
XABR		12	0001 0010	A ↔ Br (0,0 → A ₃ ,A ₂)	None	Exchange A with Br
TEST INSTRUCTIONS						
SKC		20	0010 0000		C = "1"	Skip if C is True
SKE		21	0010 0001		A = RAM(B)	Skip if A Equals RAM
SKGZ		33 21	0011 0011 0010 0001		G _{3:0} = 0	Skip if G is Zero (all 4 bits)
SKGBZ		33	0011 0011	1st byte		Skip if G Bit is Zero
	0	01	0000 0001		G ₀ = 0	
	1	11	0001 0001		G ₁ = 0	
	2	03	0000 0011	2nd byte	G ₂ = 0	
	3	13	0001 0011		G ₃ = 0	
SKMBZ		0 1 2 3	0000 0001 0001 0001 0000 0011 0001 0011		RAM(B) ₀ = 0 RAM(B) ₁ = 0 RAM(B) ₂ = 0 RAM(B) ₃ = 0	Skip if RAM Bit is Zero
SKT		41	0100 0001		A time-base counter carry has occurred since last test	Skip on Timer (Note 3)

Table 2. ET9420/9421/9422.ET9320/9321/9322 Instruction Set (continued)

Mnemonic	Operand	Hex Code	Machine Language Code (Binary)	Data Flow	Skip Conditions	Description		
INPUT/OUTPUT INSTRUCTIONS								
ING		33	<table border="1"><tr><td>0011</td><td>0011</td></tr></table>	0011	0011	G → A	None	Input G Ports to A
0011	0011							
		2A	<table border="1"><tr><td>0010</td><td>1010</td></tr></table>	0010	1010			
0010	1010							
ININ		33	<table border="1"><tr><td>0011</td><td>0011</td></tr></table>	0011	0011	IN → A	None	Input IN Inputs to A (Note 2)
0011	0011							
		28	<table border="1"><tr><td>0010</td><td>1000</td></tr></table>	0010	1000			
0010	1000							
INIL		33	<table border="1"><tr><td>0011</td><td>0011</td></tr></table>	0011	0011	IL ₃ , CKO, "0", IL ₀ → A	None	Input IL Latches to A (Note 3)
0011	0011							
		29	<table border="1"><tr><td>0010</td><td>1001</td></tr></table>	0010	1001			
0010	1001							
INL		33	<table border="1"><tr><td>0011</td><td>0011</td></tr></table>	0011	0011	L _{7:4} → RAM(B)	None	Input L Ports to RAM,A
0011	0011							
		2E	<table border="1"><tr><td>0010</td><td>1110</td></tr></table>	0010	1110	L _{3:0} → A		
0010	1110							
OBD		33	<table border="1"><tr><td>0011</td><td>0011</td></tr></table>	0011	0011	Bd → D	None	Output Bd to D Outputs
0011	0011							
		3E	<table border="1"><tr><td>0011</td><td>1110</td></tr></table>	0011	1110			
0011	1110							
OGI	y	33	<table border="1"><tr><td>0011</td><td>0011</td></tr></table>	0011	0011	y → G	None	Output to G Ports Immediate
0011	0011							
		5-	<table border="1"><tr><td>0101</td><td>y</td></tr></table>	0101	y			
0101	y							
OMG		33	<table border="1"><tr><td>0011</td><td>0011</td></tr></table>	0011	0011	RAM(B) → G	None	Output RAM to G Ports
0011	0011							
		3A	<table border="1"><tr><td>0011</td><td>1010</td></tr></table>	0011	1010			
0011	1010							
XAS		4F	<table border="1"><tr><td>0100</td><td>1111</td></tr></table>	0100	1111	A ↔ SIO, C → SKL	None	Exchange A with SIO (Note 3)
0100	1111							

Note 1: All subscripts for alphabetical symbols indicate bit numbers unless explicitly defined (e.g., Br and Bd are explicitly defined). Bits are numbered 0 to N where 0 signifies the least significant bit (low-order, right-most bit). For example, A₃ indicates the most significant (left-most) bit of the 4-bit A register.

Note 2: The ININ instruction is not available on the ET9421/ET932 and ET9422/ET9322 since these devices do not contain the IN inputs.

Note 3: For additional information on the operation of the XAS, JID, LQID, INIL, and SKT instructions, see below.

Note 4: The JP instruction allows a jump, while in subroutine pages 2 or 3, to any ROM location within the two-page boundary of pages 2 or 3. The .IP instruction, otherwise, permits a jump to a ROM location within the current 64-word page. JP may not jump to the last word of a page.

Note 5: A JSRP transfers program control to subroutine page 2 (0010 is loaded into the upper 4 bits of P). A JSRP may not be used when in pages 2 or 3. JSRP may not jump to the last word in page 2.

Note 6: LBI is a single-byte instruction if d = 0, 9, 10, 11, 12, 13, 14, or 15. The machine code for the lower 4 bits equals the binary value of the "d" data minus 1, e.g., to load the lower four bits of B (Bd) with the value 9 (1001₂), the lower 4 bits of the LBI instruction equal 8 (1000₂). To load 0, the lower 4 bits of the LBI instruction should equal 15 (1111₂).

Note 7: Machine code for operand field y for LEI instruction should equal the binary value to be latched into EN, where a "1" or "0" in each bit of EN corresponds with the selection or deselection of a particular function associated with each bit. (See Functional Description, EN Register.)

The following information is provided to assist the user in understanding the operation of several unique instructions and to provide notes useful to programmers in writing ET9420/9421 programs.

XAS Instruction

XAS (Exchange A with SIO) exchanges the 4-bit contents of the accumulator with the 4-bit contents of the SIO register. The contents of SIO will contain serial-in/serial-out shift register or binary counter data, depending on the value of the EN register. An XAS instruction will also affect the SK output. (See Functional Description, EN Register, above.) If SIO is selected as a shift register, an XAS instruction must be performed once every 4 instruction cycles to effect a continuous data stream.

JID Instruction

JID (Jump Indirect) is an indirect addressing instruction, transferring program control to a new ROM location pointed to indirectly by A and M. It loads the lower 8 bits of the ROM address register PC with the contents of ROM addressed by the 10-bit word, PC_{9,8}, A, M. PC₉ and PC₈ are not affected by this instruction.

Note that JID requires 2 instruction cycles to execute.

INIL Instruction

INIL (Input IL Latches to A) inputs 2 latches, IL₃ and IL₀ (see figure 10) and CKO into A. The IL₃ and IL₀ latches are set if a low-going pulse ("1" to "0") has occurred on the IN₃ and IN₀ inputs since the last INIL instruction, provided the input pulse stays low for at least two instruction times. Execution of an INIL inputs IL₃ and IL₀ into A3 and A0 respectively, and resets these latches to allow them to respond to subsequent low-going pulses on the IN₃ and IN₀ lines. If CKO is mask programmed as a general purpose input, an INIL will input the state of CKO into A2. If CKO has not been so programmed, a "1" will be placed in A2. A "0" is always placed in A1 upon the execution of an INIL. The general purpose inputs IN₃-IN₀ are input to A upon execution of an ININ instruction. (See table 2, ININ instruction.) INIL is useful in recognizing pulses of short duration or pulses which occur too often to be read conveniently by an ININ instruction.

Note: IL latches are not cleared on reset.

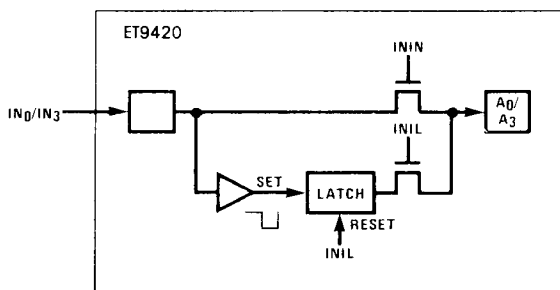

Figure 10.

LQID Instruction

LQID (Load Q Indirect) loads the 8-bit Q register with the contents of ROM pointed to by the 10-bit word PC₉, PC₈, A, M. LQID can be used for table lookup or code conversion such as BCD to seven-segment. The LQID instruction "pushes" the stack (PC + 1 → SA → SB → SC) and replaces the least significant 8 bits of PC as follows: A → PC_{7,4}, RAM(B) → PC_{3,0}, leaving PC₉ and PC₈ unchanged. The ROM data pointed to by the new address is fetched and loaded into the Q latches. Next, the stack is "popped" (SC → SB → SA → PC), restoring the saved value of PC to continue sequential program execution. Since LQID pushes SB → SC, the previous contents of SC are lost. Also, when LQID pops the stack, the previously pushed contents of SB are left in SC. The net result is that the contents of SB are placed in SC (SB → SC). Note that LQID takes two instruction cycle times to execute.

SKT Instruction

The SKT (Skip On Timer) instruction tests the state of an internal 10-bit time-base counter. This counter divides the instruction cycle clock frequency by 1024 and provides a latched indication of counter overflow. The SKT instruction tests this latch, executing the next program instruction if the latch is not set. If the latch has been set since the previous test, the next program instruction is skipped and the latch is reset. The features associated with this instruction, therefore, allow the ET9420/9421 to generate its own time-base for real-time processing rather than relying on an external input signal.

For example, using a 2.097 MHz crystal as the time-base to the clock generator, the instruction cycle clock frequency will be 131 kHz (crystal frequency ÷ 16) and the binary counter output pulse frequency will be 128 Hz. For time-of-day or similar real-time processing, the SKT instruction can call a routine which increments a "seconds" counter every 128 ticks.

Instruction Set Notes

- The first word of a ET9420/9421 program (ROM address 0) must be a CLRA (Clear A) instruction.
- Although skipped instructions are not executed, one instruction cycle time is devoted to skipping each byte of the skipped instruction. Thus all program paths take the same number of cycle times whether instructions are skipped or executed except JID and LQID. LQID and JID take two cycle times if executed and one if skipped.
- The ROM is organized into 16 pages of 64 words each. The Program Counter is a 10-bit binary counter, and will count through page boundaries. If a JP, JSRP, JID or LQID instruction is located in the last word of a page, the instruction operates as if it were in the next page. For example: a JP located in the last word of a page will jump to a location in the next page. Also, a LQID or JID located in the last word of page 3, 7, 11 or 15 will access data in the next group of four pages.

Option List

The ET9420/9421/9422 mask-programmable options are assigned numbers which correspond with the ET9420 pins.

The following is a list of ET9420 options. When specifying a ET9421 or ET9422 chip, Options 9, 10, 19, 20 and 29 must all be set to zero. When specifying a ET9422 chip. Options 21, 22, 27 and 28 must also be zero, and Option 2 must not be a 1. The options are programmed at the same time as the ROM pattern to provide the user with the hardware flexibility to interface to various I/O components using little or no external circuitry.

Option 1 = 0: Ground Pin — no options available

Option 2: CKO Pin

- = 0: clock generator output to crystal
(0 not available if option 3 = 4 or 5)
- = 1: pin is RAM power supply (V_R) input
(Not available on ET9422, ET9322)
- = 2: general purpose input with load device
- = 3: multi-COP SYNC input
- = 4: general purpose Hi Z input

Option 3: CKI Input

- = 0: crystal input divided by 16
- = 1: crystal input divided by 8
- = 2: TTL external clock input divided by 16
- = 3: TTL external clock input divided by 8
- = 4: single-pin RC controlled oscillator (+4)
- = 5: Schmitt trigger clock input (+4)

Option 4: RESET Pin

- = 0: Load devices to V_{CC}
- = 1: Hi-Z input

Option 5: L_7 Driver

- = 0: Standard output (figure 9D)
- = 1: Open-Drain output (E)
- = 2: LED direct drive output (F)
- = 3: TRI-STATE® push-pull output (G)

Option 6: L_6 Driver

same as Option 5

Option 7: L_5 Driver

same as Option 5

Option 8: L_4 Driver

same as Option 5

Option 9: IN_1 Input

- = 0: load device to V_{CC} (H)
- = 1: Hi-Z input (I)

Option 10: IN_2 Input

same as Option 9

Option 11 = 0: V_{CC} Pin — no options available

Option 12: L_3 Driver

same as Option 5

Option 13: L_2 Driver

same as Option 5

Option 14: L_1 Driver

same as Option 5

Option 15: L_0 Driver

same as Option 5

Option 16: SI Input

same as Option 9

Option 17: SO Driver

- = 0: standard output (A)
- = 1: open-drain output (B)
- = 2: push-pull output (C)

Option 18: SK Driver

same as Option 17

Option 19: IN_0 Input

same as Option 9

Option 20: IN_3 Input

same as Option 9

Option 21: G_0 I/O Port

- = 0: Standard output (A)
- = 1: Open-Drain output (B)

Option 22: G_1 I/O Port

same as Option 21

Option 23: G_2 I/O Port

same as Option 21

Option 24: G_3 I/O Port

same as Option 21

Option 25: D_3 Output

- = 0: Standard output (A)
- = 1: Open-Drain output (B)

Option 26: D_2 Output

same as Option 25

Option 27: D_1 Output

same as Option 25

Option 28: D_0 Output

same as Option 25

Option 29: COP Function

- = 0: normal operation
- = 1: MICROBUS™ option

Option 30: COP Bonding

- = 0: ET9420 (28-pin device)
- = 1: ET9421 (24-pin device)
- = 2: 28 and 24-pin versions
- = 3: ET9422 (20-pin device)
- = 4: 28- and 20-pin versions
- = 5: 24- and 20-pin versions
- = 6: 28-, 24-, and 20-pin versio

Option 31: IN Input Levels

- = 0: normal input levels
- = 1: Higher voltage input leve
("0" = 1.2V, "1" = 3.6V)

Option 32: G Input Levels

same as Option 31

Option 33: L Input Levels

same as Option 31

Option 34: CKO Input Levels

same as Option 31

Option 35: SI Input Levels

same as Option 31

TEST MODE (Non-Standard Operation)

The SO output has been configured to provide for standard test procedures for the custom-programmed ET9420. With SO forced to logic "1", two test modes are provided, depending upon the value of SI :

- a. RAM and Internal Logic Test Mode (SI = 1)
- b. ROM Test Mode (SI = 0)

These special test modes should not be employed by the user: they are intended for manufacturing test only.

APPLICATION EXAMPLE : ET9420 General Controller

Figure 9 shows an interconnect diagram for a ET9420 used as a general controller. Operation of the system is as follows :

1. The L₇-L₀ outputs are configured as LED Direct Drive outputs, allowing direct connection to the segments of the display.

2. The D₃-D₀ outputs drive the digits of the multiplexed display directly and scan the columns of the 4 × 4 keyboard matrix.
3. The IN₃-IN₀ inputs are used to input the 4 rows of the keyboard matrix. Reading the IN lines in conjunction with the current value of the D outputs allows detection, debouncing, and decoding of any one of the 16 keyswitches.
4. CKI is configured as a single-pin oscillator input allowing system timing to be controlled by a single-pin RC network. CKO is therefore available for use as a V_R RAM power supply pin. RAM data integrity is thereby assured when the main power supply is shut down (see RAM Keep-Alive Option description).
5. SI is selected as the input to a binary counter input. With SIO used as a binary counter. SO and SK can be used as general purpose outputs.
6. The 4 bidirectional G I/O ports (G₃-G₀) are available for use as required by the user's application.

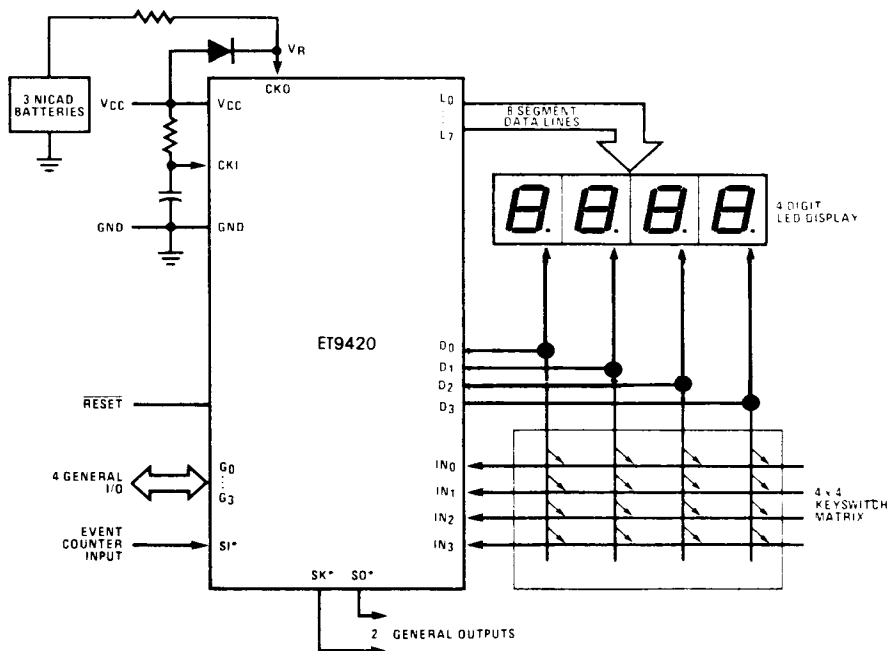

*SI, SO and SK may also be used for serial I/O

Figure 11. ET9420 Keyboard/Display Interface

Physical Dimensions inches (millimeters)

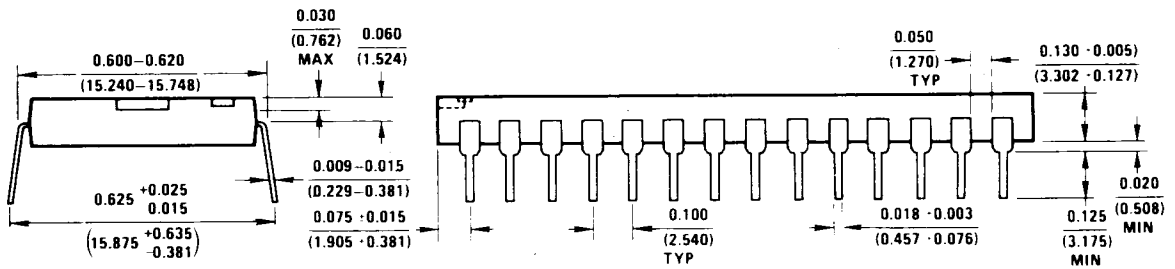
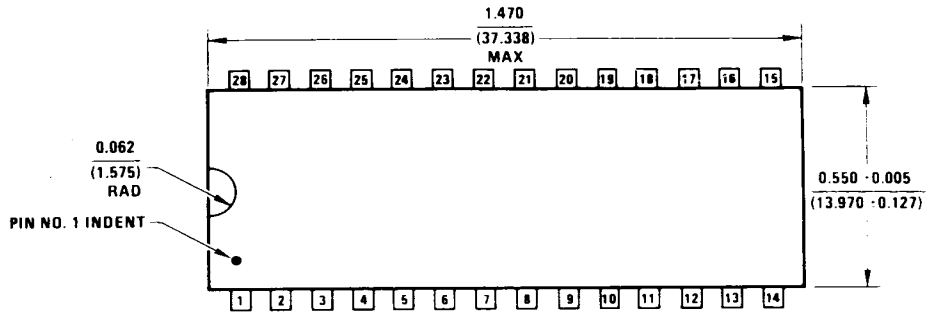

Molded Dual-In-Line Package (N)
Order Number ET9420 N or ET9320 N
Package Number N28A

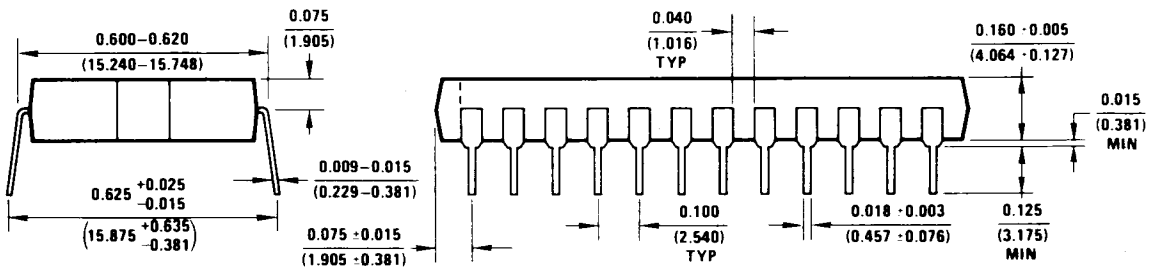
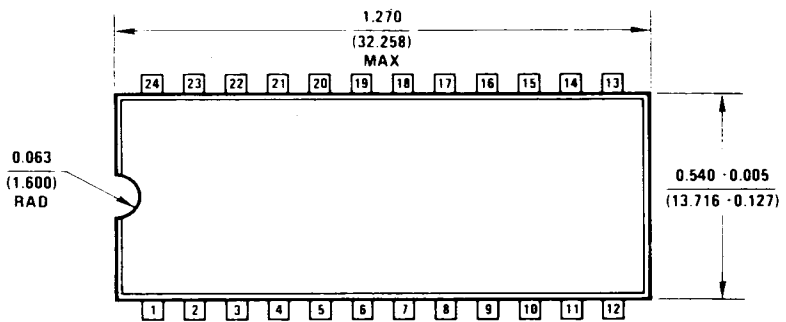

Molded Dual-In-Line Package (N)
Order Number ET9421N or ET9321 N
Package Number N24A

EUROTECHNIQUE

Eurotechnique : 3, place Gustave Eiffel, Silic
209, 94518 Rungis Cedex, France,
Tél. (1) 687.23.03, Telex : 201068

Eurotechnique Semiconductor Ltd : 4 th floor
Lambourne House, 7 Western Road, Romford,
Essex RM 1 3LD, UK, Tel. (708) 27.488,
Telex : 896683

E.T.S. Eurotechnique Semiconductor Verkaufs-
GmbH, Neusser Strasse 9, D-8000 Munich 40,
Germany, Tel. (89) 36.30.85/86,
Telex : 528283

Headquarters, International Sales Office and Factory : Eurotechnique B.P. 2, 13790 Rousset, France, tel. (42) 23.98.01, telex : 440.306 F

Eurotechnique does not assume any responsibility for use of any circuitry described, no circuit patent licenses are implied, and Eurotechnique reserves the right, at any time without notice, to change said circuitry