

Silicon NPN Power Transistors

2SC4981

DESCRIPTION

- With ITO-220 package
- Switching power transistor
- Low collector saturation voltage

PINNING

PIN	DESCRIPTION
1	Base
2	Collector
3	Emitter

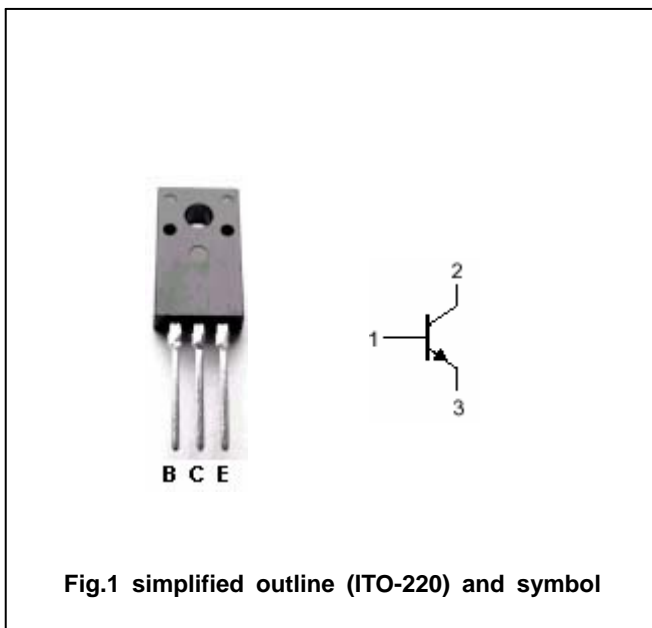

Fig.1 simplified outline (ITO-220) and symbol

Absolute maximum ratings(Ta=25)

SYMBOL	PARAMETER	CONDITIONS	VALUE	UNIT
V _{CBO}	Collector-base voltage	Open emitter	100	V
V _{CEO}	Collector-emitter voltage	Open base	80	V
V _{EBO}	Emitter-base voltage	Open collector	7	V
I _C	Collector current		7	A
I _{CM}	Collector current-Peak		14	A
I _B	Base current		1.5	A
I _{BM}	Base current-peak		2	A
P _T	Total power dissipation	T _C =25	25	W
T _j	Junction temperature		150	
T _{stg}	Storage temperature		-55~150	

THERMAL CHARACTERISTICS

SYMBOL	PARAMETER	MAX	UNIT
R _{th j-C}	Thermal resistance junction case	5.0	/W

Silicon NPN Power Transistors

2SC4981

CHARACTERISTICS

T_j=25 unless otherwise specified

SYMBOL	PARAMETER	CONDITIONS	MIN	TYP.	MAX	UNIT
V _{CEO(SUS)}	Collector-emitter sustaining voltage	I _C =0.1A ; I _B =0	80			V
V _{CEsat}	Collector-emitter saturation voltage	I _C =3.5A; I _B =0.2A			0.3	V
V _{BEsat}	Base-emitter saturation voltage	I _C =3.5A; I _B =0.2A			1.2	V
I _{CBO}	Collector cut-off current	At rated volatge			0.1	mA
I _{CEO}	Collector cut-off current					
I _{EBO}	Emitter cut-off current	At rated volatge			0.1	mA
h _{FE}	DC current gain	I _C =3.5A ; V _{CE} =2V	70			
f _T	Transition frequency	I _C =0.7A ; V _{CE} =10V		50		MHz

Switching times

t _{on}	Turn-on time	I _C =3.5A; I _{B1} =0.35A I _{B2} =0.35A , R _L =8 V _{BB2} =4V			0.3	μs
t _s	Storage time				1.5	μs
t _f	Fall time				0.2	μs

Silicon NPN Power Transistors

2SC4981

PACKAGE OUTLINE

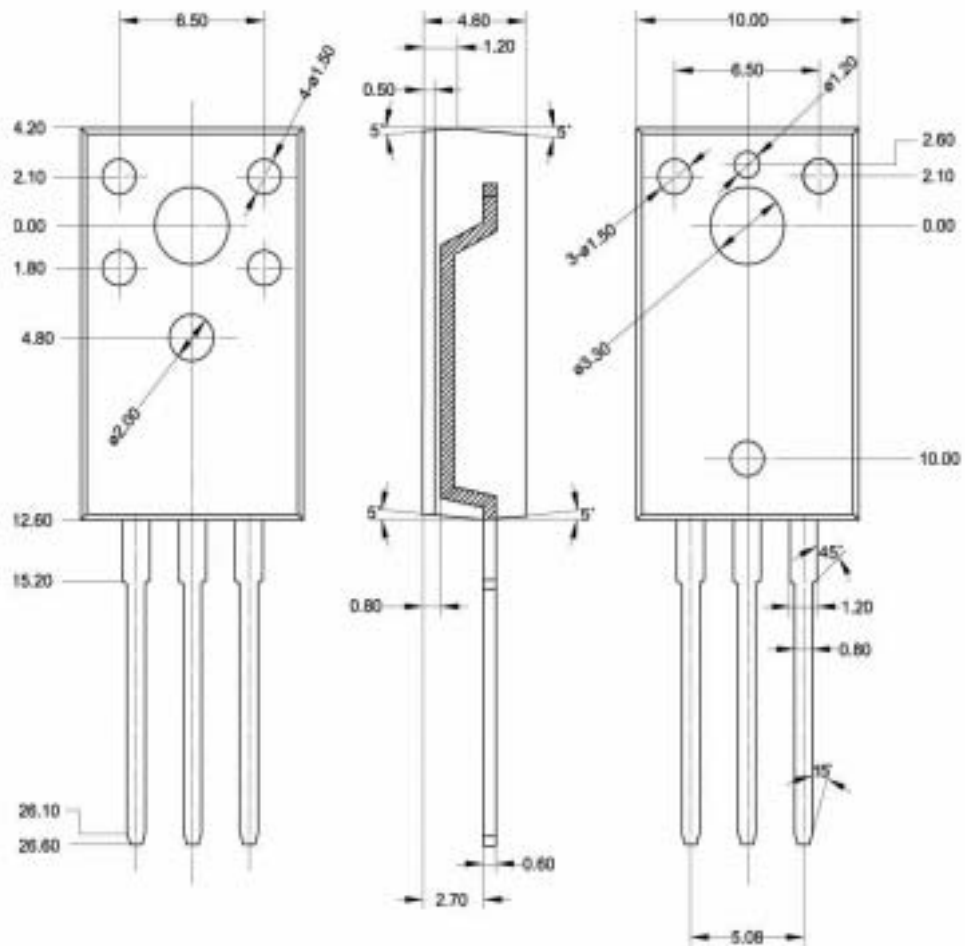

Fig.2 Outline dimensions (unindicated tolerance: ± 0.20 mm)