

CENTER CONTACT

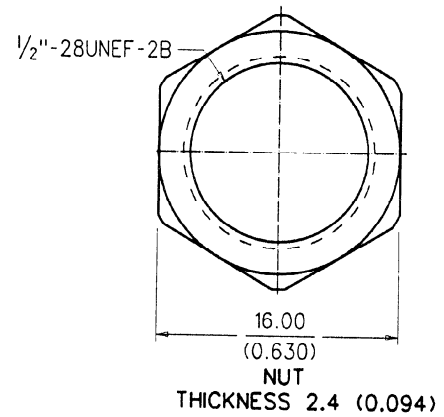

NUT
THICKNESS 2.4 (0.094)

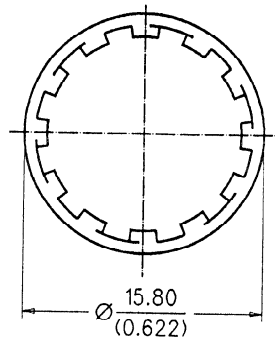

WASHER
THICKNESS 0.5(0.019)

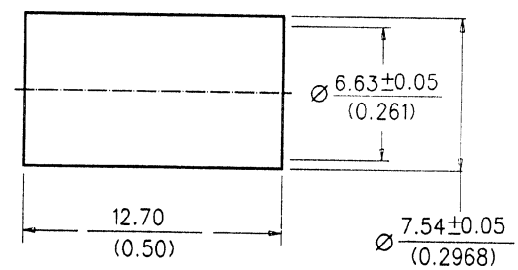

FERRULE

CABLE ATTACHMENT:
 INNER CONTACT-----CRIMP(1.69 HEX.)
 OR SOLDER
 OUTER CONDUCTOR-----CRIMP(6.48 HEX.)
 ASSEMBLY INSTRUCTION--AS-73597-0039/B

FINISH :
 CONNECTOR BODY-----NICKEL PLATING
 CENTER CONTACT-----GOLD PLATING
 FERRULE -----NICKEL PLATING
 NUT-----NICKEL PLATING
 WASHER-----NICKEL PLATING

CONSTRUCTION:
 CONNECTOR BODY-----BRASS
 DIELECTRIC-----TEFLON
 CENTER CONTACT-----PHOSPHOR BRONZE
 FERRULE -----BRASS
 NUT-----BRASS
 WASHER-----PHOSPHOR BRONZE

MECHANICAL & ELECTRICAL CHARACTERISTICS:
 PER PRODUCT SPECIFICATION PS-73598-0001

MATERIAL & FINISH CHARACTERISTICS:
 PER PRODUCT SPECIFICATION PS-73598-0001

PACKAGING:
 INDIVIDUAL PLASTIC BAGS

				MATERIAL : SEE NOTE		MOLEX TAIWAN LTD. (R.F. DIVISION)	
				FINISH : SEE NOTE			
				SCALE : 4:1 UNIT : mm/(inch)		GENERAL TOLERANCES ANGLE : ± 3° DIM. ± 0.25	
				DRAWN BY : <i>M. Hsu</i> 1993/03/22		DRW. NO. : SDA-73100-0002 REV. B	
				CHK'D BY : <i>W. Wang</i> 93/10/15		TITLE : 75 OHMS BNC JACK STRAIGHT BULKHEAD	
				APPR'D BY : <i>[Signature]</i> 1993/03/22		RC59B/U,62A/U CRIMP/CRIMP	
LTR REVISION RECORD ECN DR/CHK DATE				STANDARD ITEM <input checked="" type="checkbox"/> YES <input type="checkbox"/> NO		SHEET 1 OF 1	

ENG. NO.
 EDP. NO.
 SIMILAR ITEM
 PROJECT NO.
 DO NOT SCALE DRAWING