

**Product Features:**

- Small Surface Mount Package
- Low Noise
- Pb Free/ RoHS Compliant
- Compatible with Leadfree Processing

**Applications:**

- SD/HD Video
- Wireless Base Stations
- Sonet /SDH
- Server and Storage

<b>Frequency</b>	1 MHz to 180.000 MHz
<b>Output Level</b> LVDS LVPECL	Vod = 393 mV Typ., 475 mV Max. '0' = Vcc - 1.63 V Max. '1' = Vcc - 1.02 V Min.
<b>Duty Cycle</b>	50% ±10%
<b>Rise / Fall Time</b>	0.6 nS Max.
<b>Output Load</b> LVDS LVPECL	100 Ω Differential 50 Ω to Vcc - 2.0 VDC
<b>Frequency Stability</b>	50 ppm Max.
<b>Start-up Time</b>	10 mS Max.
<b>Supply Voltage</b>	3.3 VDC ± 5%
<b>Current</b>	LVDS = 90 mA Max., LVPECL = 130 mA Max.
<b>Linearity</b>	15% Max.
<b>Pullability</b>	See Table Below
<b>Control Voltage</b>	1.65 VDC ± 1.5 VDC
<b>Input Impedance</b>	50K Ω Min.
<b>Jitter</b>	<1.0 pS RMS (12 kHz to 20 MHz)*
<b>Operating</b>	See Operating Temperature Table in Part Number Guide
<b>Storage</b>	-55° C to +125° C

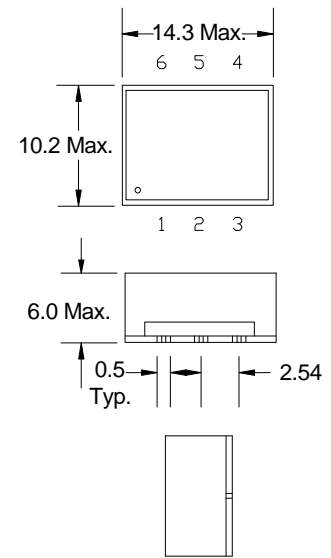

Recommended pad layout

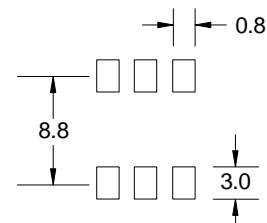

- Pin Connection
- 1 Voltage Control
  - 2 Enable/Disable
  - 3 GND
  - 4 Output
  - 5 Comp. Output
  - 6 Vcc

Dimension Units: mm

Part Number Guide		Sample Part Number: I606-1BC8H-155.520				
Package	Operating Temperature	Stability (in ppm)	Pullability	Output	Enable / Disable	Frequency
I606	1 = 0° C to +70° C	**D = ±15	B = ±50 ppm	8 = LVDS	H = Enable	-155.520 MHz
	3 = -20° C to +70° C	A = ±25	C = ±100 ppm	9 = LVPECL		
	2 = -40° C to +85° C	B = ±50				
		C = ±100				

NOTE: A 0.01 µF bypass capacitor is recommended between Vcc (pin 6) and GND (pin 3) to minimize power supply noise.

\*Frequency related, for additional information contact your sales representative. \*\* Not available for all temperature ranges.



10 mm x 14 mm, FR-4 SMD VCXO, LVPECL / LVDS



I606 Series

**Pb Free Solder Reflow Profile:**

**Typical Application:**

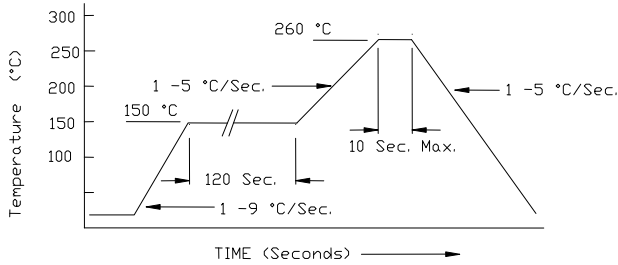

\*Units are backward compatible with 240C reflow processes

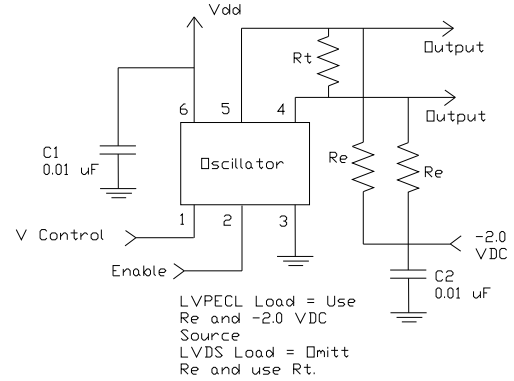

**Package Information:**

MSL = N.A. (package does not contain plastic, storage life is unlimited under normal room conditions).  
 Termination = e4 (Au over Ni over W base metalization).

**Tape and Reel Information:**

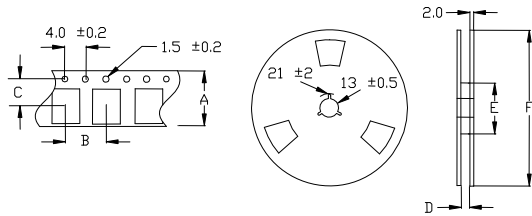

Quantity per Reel	1000
A	16 +/- .3
B	8 +/- .2
C	7.5 +/- .2
D	17.5 +/- 1
E	50 / 60 / 80
F	180 / 250

**Environmental Specifications**

Thermal Shock	MIL-STD-883, Method 1011, Condition A
Moisture Resistance	MIL-STD-883, Method 1004
Mechanical Shock	MIL-STD-883, Method 2002, Condition B
Mechanical Vibration	MIL-STD-883, Method 2007, Condition A
Resistance to Soldering Heat	J-STD-020C, Table 5-2 Pb-free devices (except 2 cycles max)
Hazardous Substance	Pb-Free / RoHS / Green Compliant
Solderability	JESD22-B102-D Method 2 (Preconditioning E)
Terminal Strength	MIL-STD-883, Method 2004, Test Condition D
Gross Leak	MIL-STD-883, Method 1014, Condition C
Fine Leak	MIL-STD-883, Method 1014, Condition A2, R1=2x10 <sup>-8</sup> atm cc/s
Solvent Resistance	MIL-STD-202, Method 215

**Marking**

Line 1: ILSI and Date Code (YWW)  
 Line 2: XXXXX (I606-XXXXX- Freq)  
 Line 3: Frequency