



**5. Pin description**

Pin No.	Symbol	Input/output	Functions	
1,2	C1, C2		External capacitor connection	By connecting external capacitor, a voltage feedback amplifier is formed. The gain of it is determined by capacitor's value.
3	DETECT	I	Detecting input	Connect a photodiode to supply a signal to the internal comparator.
4	STROBE	O	Strobe	A strobe voltage output, referenced to VDD. When output = VDD -5V, it enables other internal circuits.
5,14	VDD, GND		Power supply	To supply the power
6	IREDD	O	Output signal	To output pulse drive signal for external NPN transistor which drives a IR photodiode.
7	I/O		Input/output	It can be used to connect up to 40 detectors to make auxiliary alarm, remote alarm, auto-dialer...
8,9	BRASS, SILVER	O	Push-pull driver's output	Push-pull driver outputs signal to drive external buzzer to alarm, and to show various operation states.
10	FEEDBACK	I	Feedback terminal	To feed 'silver' signal back to the push-pull output driver circuit's input
11	LED	O	Output signal	It is an open drain output, can drive LED directly. The LED can tell the detector's various operation states.
12	OSC	I	Oscillator's input	Connected to external R and C, which determine the internal oscillator's frequency.
13	R1		External R and C connecting terminal	Connected to external R and C, which determine the output pulse period of IREDD.
15	LOW-SUPPLY	I	Low voltage detecting input	It connected to external resistor divider between VDD and LED to get a low supply alarm threshold voltage
16	TEST	I	Test terminal	This pin is normally low by an internal pull-down device. When it is set high, the IC enters into a simulated-smoke condition. When floating, this pin comes back to VSS (low) by pull-down device.

**6. Function of this IC:**

6.1. The variable gain photoelectric amplifier is directly connected to IR detector (photodiode). The amplifier's gain is determined by external capacitors C1 and C2. During standby, the amplifier's gain is at minimum. Under smoke condition, the amplifier's gain is at medium. Entering into test condition, the amplifier's gain is at maximum. Additionally, under standby state, if the special supervisory circuit is activated to check the chamber's sensitivity, the amplifier's gain is also at its maximum.

6.2. Using VSS as its reference, the I/O pin can be used to connect up to 40 units together. When I/O pin is used as an input, its on-chip pull-down resistor can prevent noise from entering

into the unit. Under smoke status, the unit activates I/O driver to send a signal to its interconnected units to activate remote alarm.

6.3. Display method: LED (connected to LED pin) flashing combined with alarm sound, indicates a LOCAL SMOKE condition. Only pulsating alarm sound without LED flashing indicates a REMOTE SMOKE condition.

## 7. Specifications:

### 7.1. Absolute maximum ratings(VSS as reference)

Symbol	Parameter	Limits	Units
VDD	Supply voltage	-0.5 ~ +12	V
VIN DC input voltage	C1, C2, Detect	-0.25 ~ Vdd+0.25	
	OSC, low-supply trip	-0.25 ~ Vdd+0.25	
	I/O	-0.25 ~ Vdd+0.25	
	Feedback	-15 ~ +15	
	Test	-1.0 ~ Vdd+0.25	
IIN	DC input current	± 10	mA
IOUT	DC output current	± 25	mA
IDD	Supply current	+25/-150	mA
PD	Power dissipation in still air, 5Sec	1200	mW
	Continuous	350	
TSTG	Storage temperature	-55 ~ 125	°C

### 7.2 Electrical characteristics(Ta = 25°C, VSS as reference, unless otherwise indicated)

Symbol	Parameters	Test condition	VDD	Min.	Max.	Unit
VDD	Power supply voltage range		--	6.0	12	V
VTH	Supply threshold voltage, Low supply alarm voltage	Low supply trip voltage VIN = VDD/3		6.5	7.8	V
IDD	Average supply current	Standby, (See sample figure)	12	--	12	uA
iDD	Supply peak current	Strobe on, IRED off (See sample figure)	12	--	2.0	mA
VIL	Low level input voltage, I/O Feedback Test		9.0		1.5	V
			9.0		2.7	
			9.0		7.0	
VIH	High level input voltage I/O Feedback Test		9.0	3.2		V
			9.0	6.3		
			9.0	8.5		
IIN	Input current OSC, Detect Low supply trip Feedback	VIN = VSS or VDD	12		± 100	nA
		VIN = VSS or VDD	12		± 100	
		VIN = VSS or VDD	12		± 100	
		VIN = VSS or VDD	12		± 100	

IIL	Low level input current TEST		VIN = VSS	12		-1	uA
IIH	Pull-down current Test I/O		VIN = VDD No local smoke, VIN = VDD No local smoke, VIN = 17V	9.0 9.0 12	0.5 25 --	10 100 140	uA
VOL	Low level output voltage, LED Silver, Brass		IOUT = 10mA IOUT = 16mA	6.5 6.5		0.6 1.0	V
VOH	High level output voltage Silver, Brass		IOUT = -16mA	6.5	5.5	-	V
VOUT	Output voltage (See pin description)	Strobe	Inactive, IOUT = -1uA Active, IOUT = 100uA to 500uA (load regulation)	- 9.0	VDD -0.1 VDD -4.4	Vdd-5.6	V
		IREDD	Inactive, IOUT =-1uA Active, IOUT =6uA (load regulation)	- 9.0	- 2.25	1 3.75	
IOH	High-level output current, I/O		Local smoke, VOUT =4.5V	6.5	-4	--	mA
			Local smoke, VOUT = VSS (short-circuit current)	12	--	-16	
IOZ	Output off-state leak current, LED		VOUT = VSS or VDD	12	-	±1	uA
VIC	Common-mode voltage range C1, C2, Detect		Local smoke, Pushbutton test or chamber sensitivity test	--	VDD -4	VDD -2	V
VREF	Internal reference voltage of smoke comparator		Local smoke, pushbutton test or chamber sensitivity test	--	VDD-3.08	VDD-3.92	V

8. Application sample figure

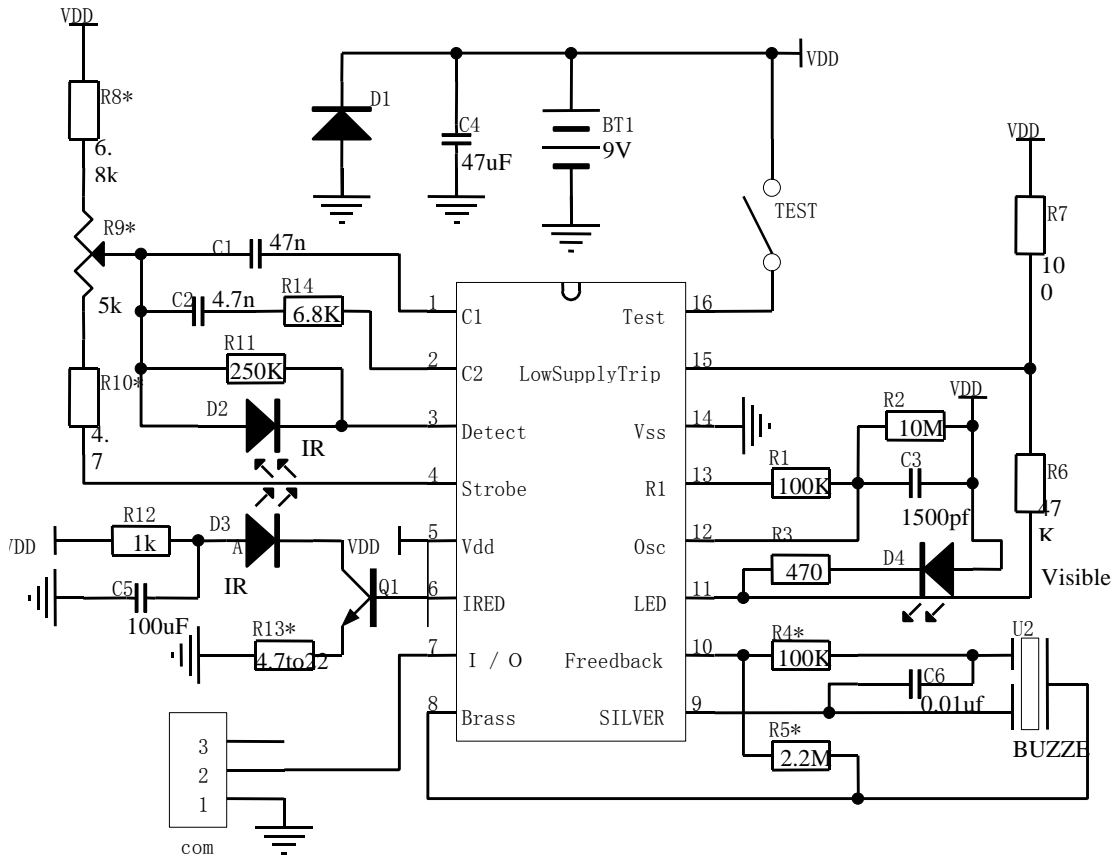

**9. Calibration:**

To enter calibration mode, pin16 (TEST) must be below VSS, pulling more than 100uA continuously out of the pin for at least one OSC cycle. To exit this mode, the TEST pin is floated at least one OSC cycle.

Table. Configuration of pins in the calibration mode

Description	PIN	Comments
I/O	7	Forcing this pin = VDD, places photo amp's output on pin2 when pin15= VDD, or on pin1 when pin15= VSS.
Low-supply	15	Low: normal gain of photo amplifier on pin1. High: supervisory gain on pin2.
Feedback	10	When pin15=low, driving it high enables gain with a hysteresis in the photo amp.
OSC	12	It equals to internal clock.
Silver	9	This pin becomes smoke comparator's output. Positive pulses indicate that smoke has been detected. A static low level indicates no smoke.
Brass	8	This pin becomes the smoke integrator's output. Static high level means two consecutive smoke detections. Static low level means two no-detections.

**Package**

BL59A10

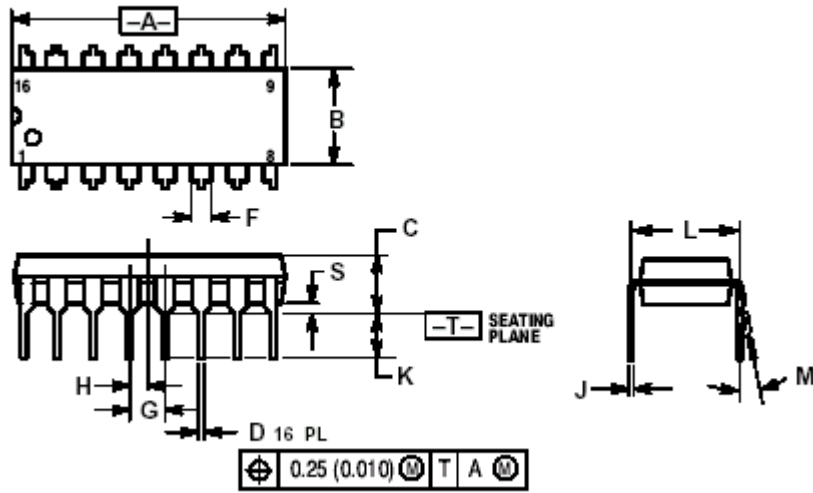

DIM	INCHES		MILLIMETERS	
	MIN	MAX	MIN	MAX
A	0.740	0.770	18.80	19.55
B	0.250	0.270	6.35	6.85
C	0.145	0.175	3.69	4.44
D	0.015	0.021	0.39	0.53
F	0.040	0.70	1.02	1.77
G	0.100 BSC		2.54 BSC	
H	0.050 BSC		1.27 BSC	
J	0.008	0.015	0.21	0.38
K	0.110	0.130	2.80	3.30
L	0.295	0.305	7.50	7.74
M	0°	10°	0°	10°
S	0.020	0.040	0.51	1.01

BL59S10

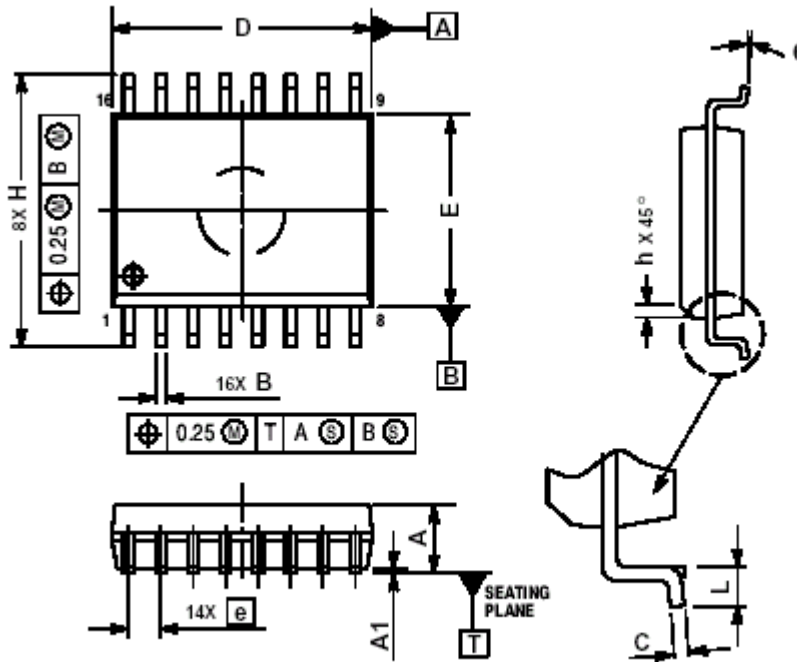

DIM	MILLIMETERS	
	MIN	MAX
A	2.35	2.65
A1	0.10	0.25
B	0.35	0.49
C	0.23	0.32
D	10.15	10.45
E	7.40	7.60
e	1.27 BSC	
H	10.05	10.55
h	0.25	0.75
L	0.50	0.90
$\theta$	0 $^\circ$	7 $^\circ$