



Features

- Low Noise and High Intercept Point
- Adjustable Bias Current
- Power Down Control
- Single 2.5V to 5.0V Power Supply
- 150MHz to 2500MHz Operation

Applications

- CDMA/FM Cellular PCS LNA
- Low Noise Transmit Driver Amplifier
- General Purpose Amplification
- Commercial and Consumer Systems

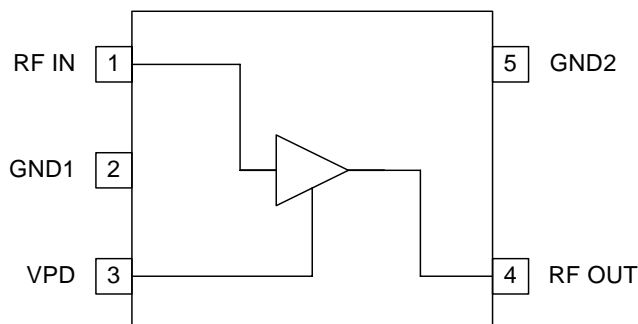

Functional Block Diagram

Product Description

The RF2878 is a low noise amplifier with a very high dynamic range designed for digital cellular applications. The device functions as an outstanding front end low noise amplifier or power amplifier driver amplifier in the transmit chain of digital subscriber units where low transmit noise power is a concern. When used as an LNA, the bias current can be set externally. When used as a PA driver, the IC can operate directly from a single cell Li-ion battery and includes a power down feature that can be used to completely turn off the device. The IC is featured in a standard SOT 5-lead plastic package.

Ordering Information

RF2878	3V Low Noise Amplifier/ 3V PA Driver Amplifier
RF2878 PCBA-D	Fully Assembled Evaluation Board (Driver)
RF2878 PCBA-L	Fully Assembled Evaluation Board (LNA)

Optimum Technology Matching® Applied

- | | | | |
|--|--------------------------------------|-------------------------------------|-----------------------------------|
| <input checked="" type="checkbox"/> GaAs HBT | <input type="checkbox"/> SiGe BiCMOS | <input type="checkbox"/> GaAs pHEMT | <input type="checkbox"/> GaN HEMT |
| <input type="checkbox"/> GaAs MESFET | <input type="checkbox"/> Si BiCMOS | <input type="checkbox"/> Si CMOS | <input type="checkbox"/> RF MEMS |
| <input type="checkbox"/> InGaP HBT | <input type="checkbox"/> SiGe HBT | <input type="checkbox"/> Si BJT | |

RF MICRO DEVICES®, RFMD®, Optimum Technology Matching®, Enabling Wireless Connectivity™, PowerStar®, POLARIS™ TOTAL RADIO™ and UltimateBlue™ are trademarks of RFMD, LLC. BLUETOOTH is a trademark owned by Bluetooth SIG, Inc., U.S.A. and licensed for use by RFMD. All other trade names, trademarks and registered trademarks are the property of their respective owners. ©2006, RF Micro Devices, Inc.

Absolute Maximum Ratings

Parameter	Rating	Unit
Supply Voltage, V_{CC}	≤ 5	V
Power Down Voltage, V_{PD}	≤ 3	V
Input RF Level	+10	dBm
Operating Ambient Temperature	-40 to +85	$^{\circ}\text{C}$
Storage Temperature	-40 to +150	$^{\circ}\text{C}$
Operating Junction Temperature	150	$^{\circ}\text{C}$
I_{CC}	30	mA



Caution! ESD sensitive device.

Exceeding any one or a combination of the Absolute Maximum Rating conditions may cause permanent damage to the device. Extended application of Absolute Maximum Rating conditions to the device may reduce device reliability. Specified typical performance or functional operation of the device under Absolute Maximum Rating conditions is not implied.

RoHS status based on EU Directive 2002/95/EC (at time of this document revision).

The information in this publication is believed to be accurate and reliable. However, no responsibility is assumed by RF Micro Devices, Inc. ("RFMD") for its use, nor for any infringement of patents, or other rights of third parties, resulting from its use. No license is granted by implication or otherwise under any patent or patent rights of RFMD. RFMD reserves the right to change component circuitry, recommended application circuitry and specifications at any time without prior notice.

Parameter	Specification			Unit	Condition
	Min.	Typ.	Max.		
Overall					
RF Frequency Range	150		2500	MHz	
Low Noise Amplifier 881MHz Performance					Schematic per LNA Application; $T = 25^{\circ}\text{C}$, $\text{RF} = 881\text{MHz}$, $V_{PD} = 2.8\text{V}$, $R1 = 1\text{k}\Omega$
Gain		20		dB	$V_{CC} = 3.0\text{V}$, $I_{CC} = 7.6\text{mA}$
		20		dB	$V_{CC} = 2.7\text{V}$, $I_{CC} = 7.5\text{mA}$
Noise Figure		1.4	1.6	dB	$V_{CC} = 3.0\text{V}$, $I_{CC} = 7.6\text{mA}$
		1.4	1.6	dB	$V_{CC} = 2.7\text{V}$, $I_{CC} = 7.5\text{mA}$
Input IP3		+6.0		dBm	$V_{CC} = 3.0\text{V}$, $I_{CC} = 7.6\text{mA}$
		+5.5		dBm	$V_{CC} = 2.7\text{V}$, $I_{CC} = 7.5\text{mA}$
Low Noise Amplifier 1950MHz Performance					Schematic per LNA Application; $T = 25^{\circ}\text{C}$, $\text{RF} = 1950\text{MHz}$, $V_{PD} = 2.8\text{V}$, $R1 = 1\text{k}\Omega$
Gain		13		dB	$V_{CC} = 3.0\text{V}$, $I_{CC} = 6.4\text{mA}$
		13		dB	$V_{CC} = 2.7\text{V}$, $I_{CC} = 6.3\text{mA}$
Noise Figure		1.3	1.5	dB	$V_{CC} = 3.0\text{V}$, $I_{CC} = 6.4\text{mA}$
		1.3	1.5	dB	$V_{CC} = 2.7\text{V}$, $I_{CC} = 6.3\text{mA}$
Input IP3		+16.5		dBm	$V_{CC} = 3.0\text{V}$, $I_{CC} = 6.4\text{mA}$
		+16.0		dBm	$V_{CC} = 2.7\text{V}$, $I_{CC} = 6.3\text{mA}$
Driver Amplifier 836MHz Performance					Schematic per Driver Amplifier Application; $T = 25^{\circ}\text{C}$, $\text{RF} = 836\text{MHz}$, $V_{PD} = 2.8\text{V}$
Gain	19.5	20.5	21.5	dB	$V_{CC} = 3.5\text{V}$
	19.5	20.5	21.5	dB	$V_{CC} = 3.0\text{V}$
	19.5	20.5	21.5	dB	$V_{CC} = 2.7\text{V}$
Output IP3	25	+32.0	35	dBm	$V_{CC} = 3.5\text{V}$
		+29.0		dBm	$V_{CC} = 3.0\text{V}$
		+27.8		dBm	$V_{CC} = 2.7\text{V}$
Noise Figure		1.9	2.0	dB	$V_{CC} = 3.5\text{V}$
		1.85	2.0	dB	$V_{CC} = 3.0\text{V}$
		1.8	2.0	dB	$V_{CC} = 2.7\text{V}$
Reverse Isolation		25		dB	$V_{CC} = 3.5\text{V}$
		25		dB	$V_{CC} = 3.0\text{V}$
		25		dB	$V_{CC} = 2.7\text{V}$

Parameter	Specification			Unit	Condition
	Min.	Typ.	Max.		
Driver Amplifier 836MHz Performance, cont.					
Input VSWR		1.8:1	2.0:1		
Output VSWR		1.25:1	2.0:1		Using External LC network used on evaluation board.
P _{1dB}		14.4		dBm	V _{CC} =3.5V
		12.5		dBm	V _{CC} =3.0V
		11.5		dBm	V _{CC} =2.7V
Power Supply					
T = 25 °C					
Voltage (V _{CC})		3.5		V	
Voltage (V _{PD})		2.8		V	
Current Consumption - Driver Amplifier (see note 1)	14.0	21.5	29.0	mA	V _{CC} =3.5V; V _{PD} =2.8V
Power Down			10	μA	V _{CC} =3.5V; V _{PD} ≤ 0.9V
Driver Amplifier 1880MHz Performance					
Schematic per Driver Amplifier Application; T=25 °C, RF=1880MHz, V _{PD} =2.8V					
Gain		14.0		dB	V _{CC} =3.5V
		14.0		dB	V _{CC} =3.0V
		14.0		dB	V _{CC} =2.7V
Output IP3		+35.0		dBm	V _{CC} =3.5V
		+31.0		dBm	V _{CC} =3.0V
		+28.8		dBm	V _{CC} =2.7V
Noise Figure		1.85	2.0	dB	V _{CC} =3.5V
		1.8	2.0	dB	V _{CC} =3.0V
		1.75	2.0	dB	V _{CC} =2.7V
Reverse Isolation		19		dB	V _{CC} =3.5V
		19		dB	V _{CC} =3.0V
		19		dB	V _{CC} =2.7V
Input VSWR		1.6:1	2.0:1		
Output VSWR		1.6:1	2.0:1		Using External LC network used on evaluation board.
P _{1dB}	14	15.6		dBm	V _{CC} =3.5V
	13	14.1		dBm	V _{CC} =3.0V
	12	13.1		dBm	V _{CC} =2.7V

Note 1: Current consumption shown for I_{CC} only. I_{PD} typical=2.0mA with V_{PD}=2.8V

Parameter	Specification			Unit	Condition
	Min.	Typ.	Max.		
Power Supply					T = 25 °C
Voltage (V _{CC})		3.5		V	
Voltage (V _{PD})		2.8		V	
Current Consumption - Driver Amplifier (see note 2)	14	21	29	mA	V _{CC} =3.5V; V _{PD} =2.8V
Power Down			10	μA	V _{CC} =3.5V; V _{PD} ≤ 0.9V

Note 2: Current consumption shown for I_{CC} only. I_{PD} typical=2.0mA with V_{PD}=2.8V

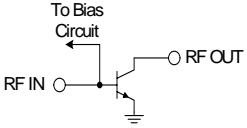
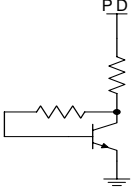
Pin	Function	Description	Interface Schematic
1	RF IN	RF input pin. This pin is DC coupled and matched to 50Ω at 836 MHz.	
2	GND1	Ground connection. Keep traces physically short and connect immediately to ground plane for best performance.	
3	VPD	For low noise amplifier applications, this pin is used to control the bias current. See plots for bias current settings. An external resistor (R1) can be used to set the bias current for any V _{PD} voltage. For driver amplifier applications, this is the Power Down pin for the IC. V _{PD} =2.8V +/- 0.1V is required for proper operation. V _{PD} < 0.9V turns off the Part. External RF bypassing is required. The trace length between the pin and the bypass capacitors should be minimized. The ground side of the bypass capacitors should connect immediately to ground plane. Nominal current required for V _{PD} =2.8V is 2.0mA typical and 3.0mA Max (@ V _{PD} =2.9V).	
4	RF OUT	Amplifier Output pin. This pin is an open-collector output. It must be biased to either V _{CC} or pin 4 through a choke or matching inductor. This pin is typically matched to 50Ω with a shunt bias/matching inductor and series blocking/matching capacitor. Refer to application schematics.	
5	GND2	Ground connection. Keep traces physically short and connect immediately to ground plane for best performance.	

Package Drawing

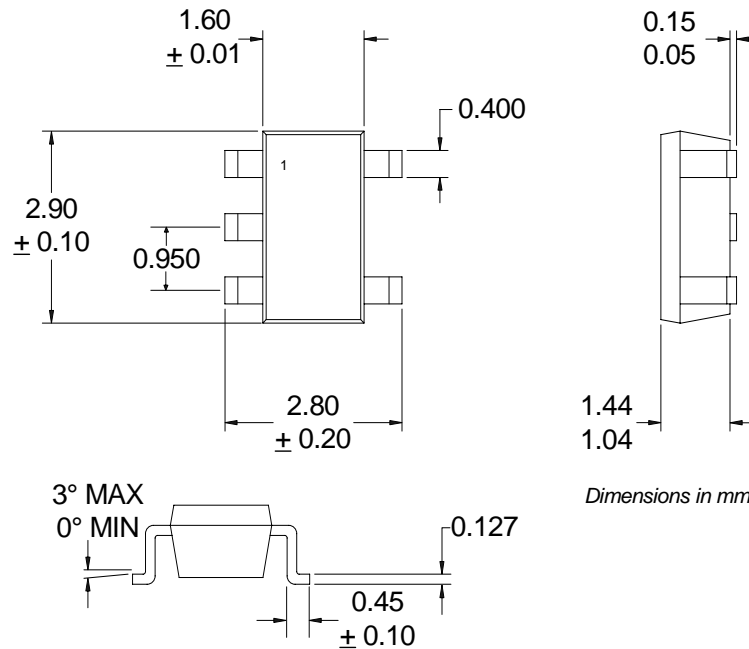

Application Schematic: 350 MHz LNA

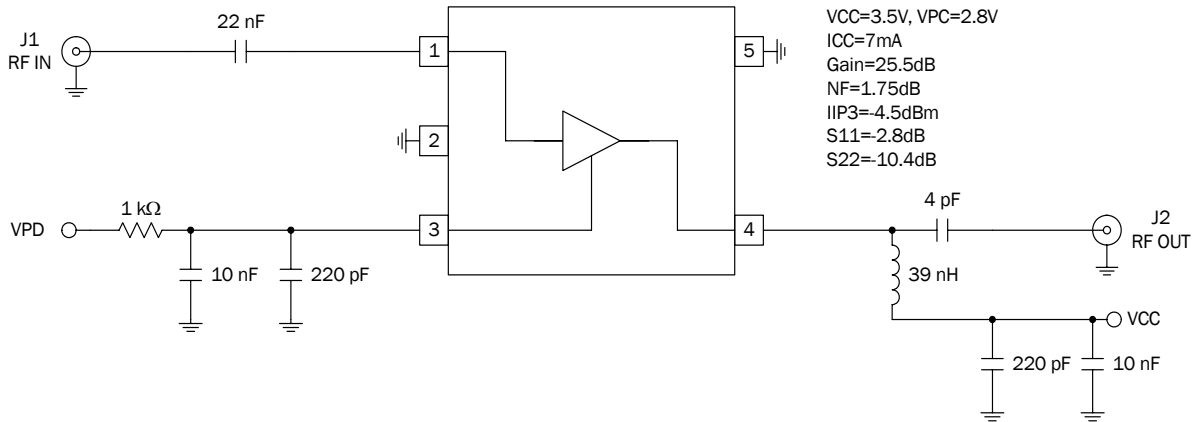

Application Schematic: 350 MHz Linear Driver

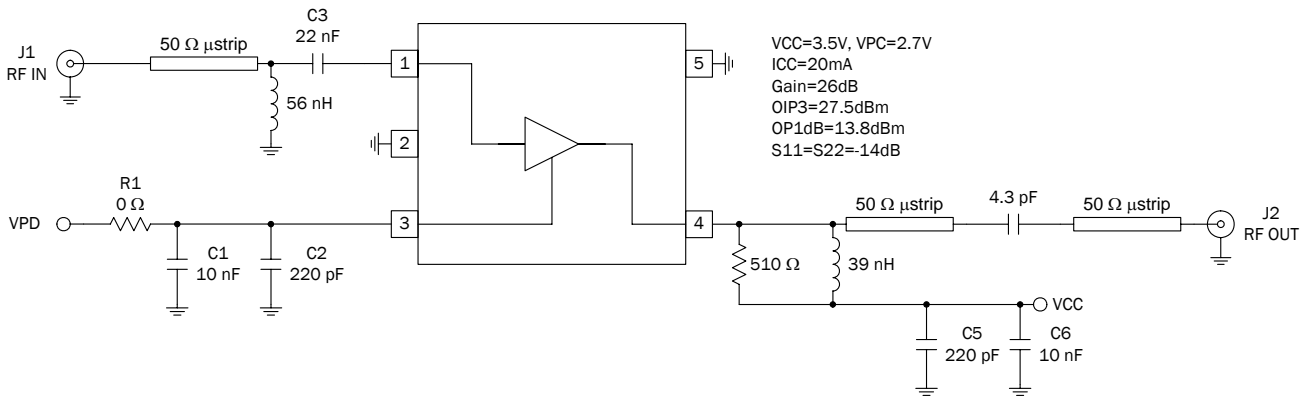

**Application Schematic:
1200 MHz to 1600 MHz Driver**
(set resistance at $V_{PD}=1000\Omega$ for LNA)

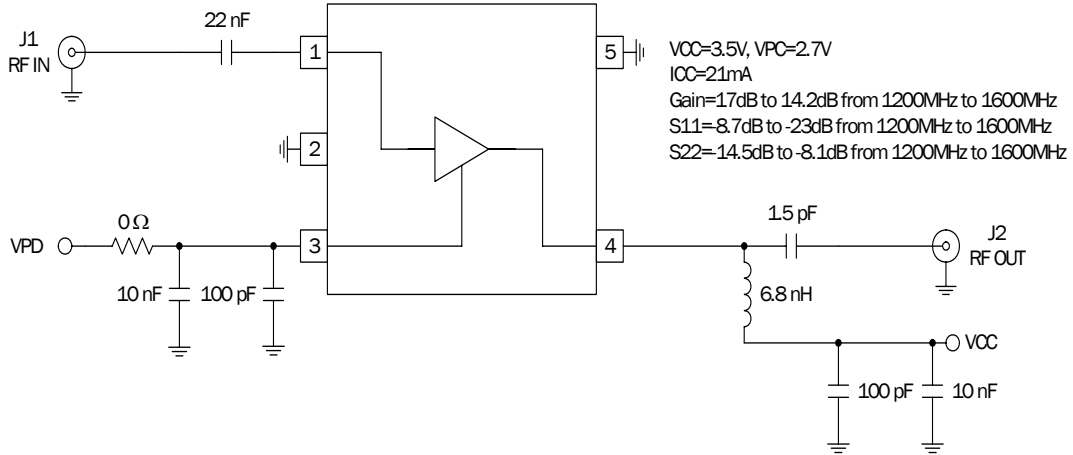

**Application Schematic:
1800 MHz to 2170 MHz Linear Driver**
(set resistance at $V_{PD}=1000\Omega$ for LNA)

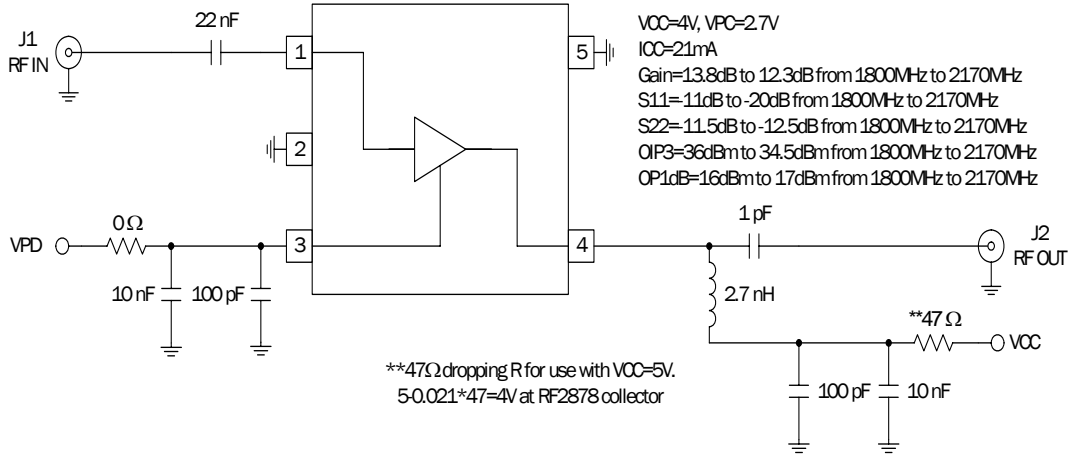

Application Schematic: Low Noise Amplifier ~1950MHz Operation

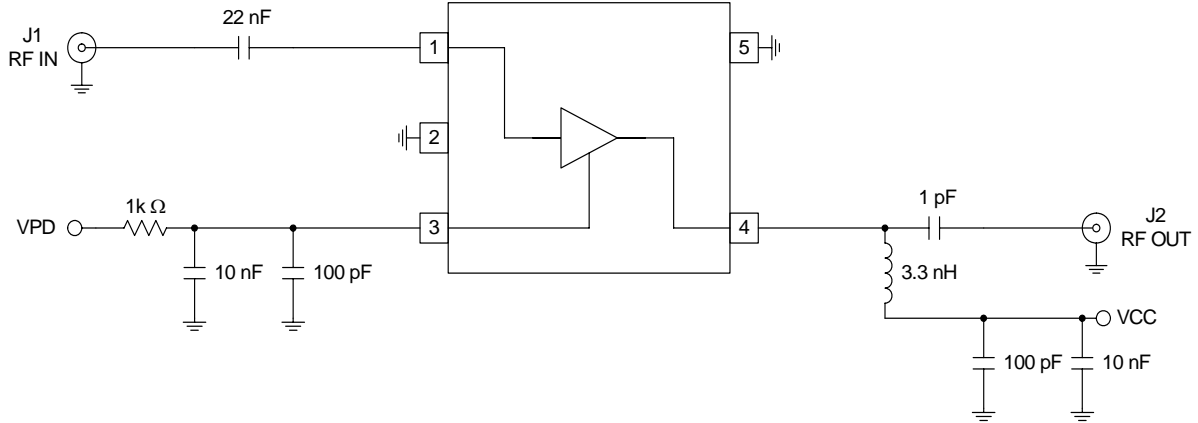

Application Schematic: Driver Amplifier ~1880MHz Operation

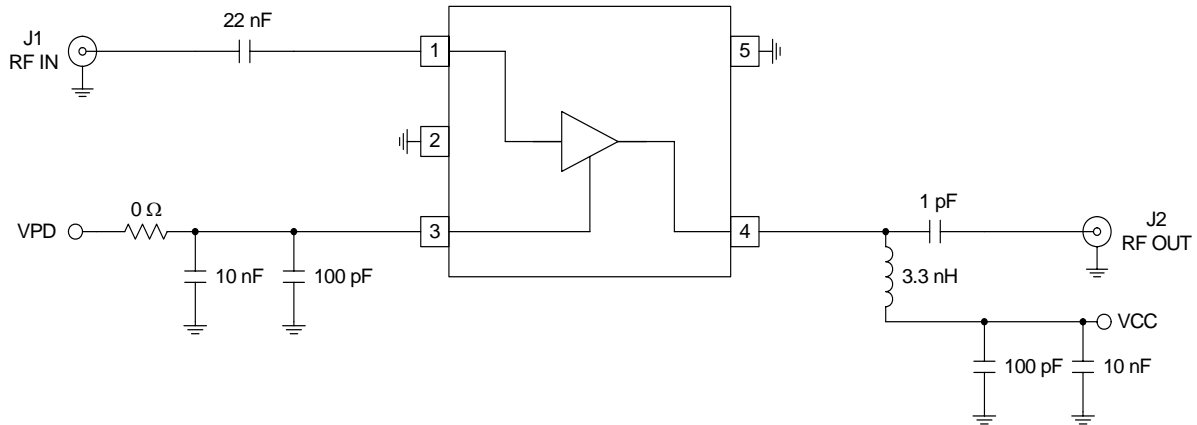

**Evaluation Board Schematic:
Low Noise Amplifier ~881MHz Operation**

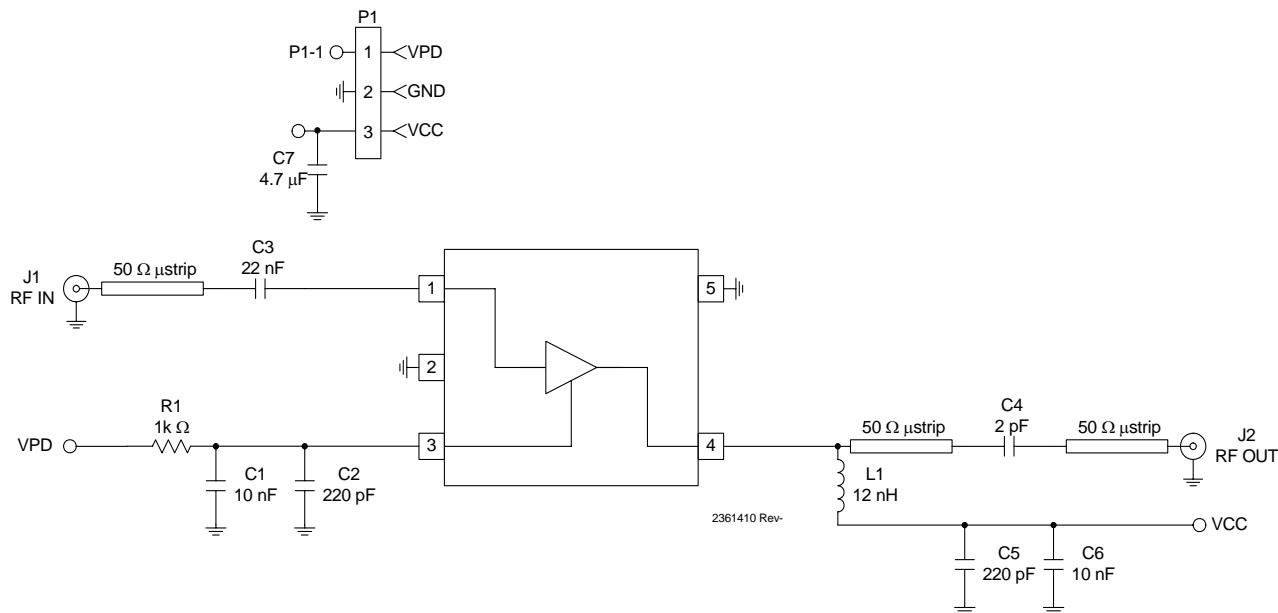

**Evaluation Board Schematic:
Driver Amplifier ~836MHz Operation**

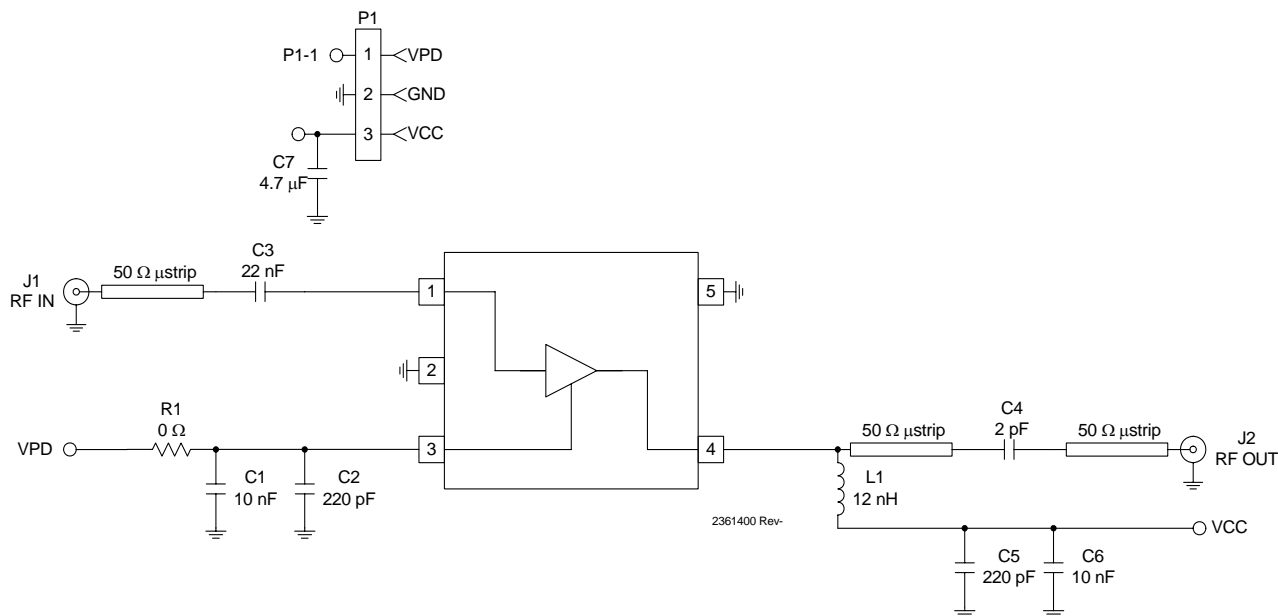

Evaluation Board Layout - 900MHz Driver

Board Size 0.948" x 1.063"
Board Thickness 0.031"; Board Material FR-4

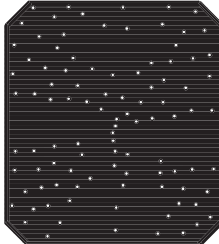
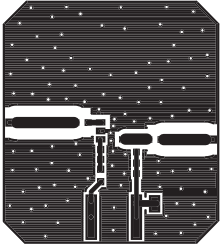
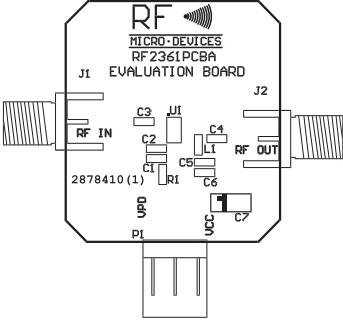

Evaluation Board Layout - 900MHz LNA

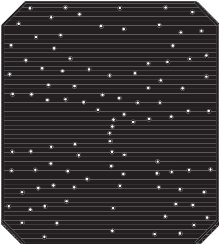
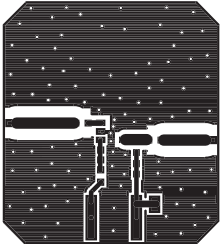
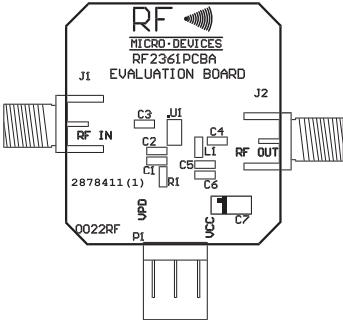

Theory of Operation

This section will focus on a variety of applications outside the nominal, for the purpose of demonstrating RF2878 versatility. Application schematics pertaining to topics discussed can be found within the data sheet for reference.

First, an application for linear driver, covering 1800MHz to 2170MHz. Operating condition:

$$V_{CC}=4V$$

$$V_{PD}=2.7V$$

$$I_{CC}=21mA$$

Note 0Ω value for bias resistor at V_{PD} in the application schematic, set for increased current/IP3. Typical specs are listed along with schematic. $V_{CC}=4V$ contributes to enhanced compression point (16dBm to 17 dBm). Junction temperature seen for ambient condition = 85 °C will be a consideration in setting V_{CC}/V_{PD} . The above biasing condition yields $T_J=132$ °C. Thus, the conditions chosen allow for highly reliable operation while providing impressive linear performance.

Using a 5V supply rail is often convenient from a design standpoint. In the 1800MHz to 2170MHz driver application already discussed, $V_{CC}=4V$ is recommended in order to maintain highest reliability. An option for using $V_{CC}=5V$ is shown in the application schematic. Use of a simple dropping resistor at V_{CC} provides 4.0V at output collector, resulting in the suggested device operating condition. Power dissipation in the resistor = 0.021 Watt, easily handled by standard resistors available to the system designer.

Moving to another application, consider the schematic for 350MHz LNA. Noise figure in this case = 1.75dB. In contrast to above linear driver, bias resistor is set at 1000Ω to limit current. In the specifications next to schematic, see that input return loss is somewhat degraded at 2.8dB. The absence of input matching is intentional, as the integrated circuit design was geared for optimum noise figure with input looking back into 50Ω. Note that in the nominal cases, 881MHz and 1950MHz, input return losses are favorable in the absence of input match.

In converting 350MHz LNA to driver, noise figure will no longer be a key specification. As such, RF2878 device s-parameter data can be used to match input for favorable return loss. The resulting driver application schematic is found below that for the LNA. When matching in bands other than those covered here, RF2878 S-parameter data can be obtained through applications/sales contact at RFMD.

As a final example, refer to driver application schematic covering 1200MHz to 1600MHz. This match provides favorable return losses over the entire band.

In summary, the examples above are intended to aid the system designer in determining suitable matches and device operating points for both LNA and driver applications. Key points to consider:

1. In setting bias condition to accommodate both LNA and driver, the first consideration is choice of bias resistance at V_{PC} . Linearity versus power dissipation trade-offs are taken into account in the driver application.
2. Noise figure versus input return loss trade-off must be considered in the specific case of low frequency LNA application. Driver application here allows for flexibility in optimizing input match for return loss.
3. Higher frequency LNA sees favorable return loss in the absence of input match. Thus, optimization at frequency >800MHz involves matching adjust to output L-C only.
4. Small signal S-parameter simulation proves an excellent method for obtaining starting point matches in the design process.

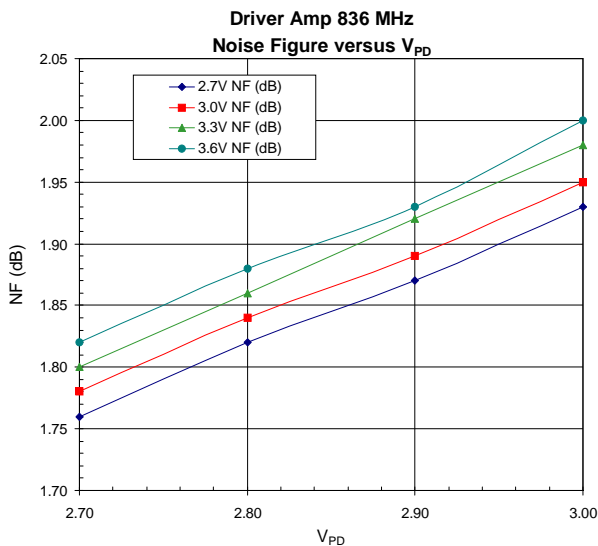
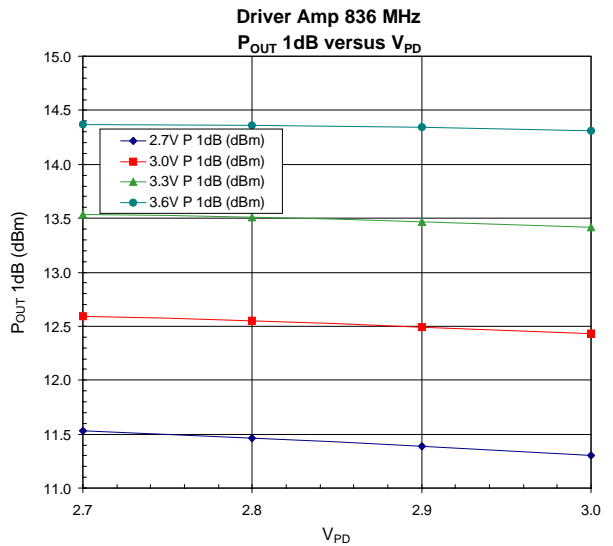
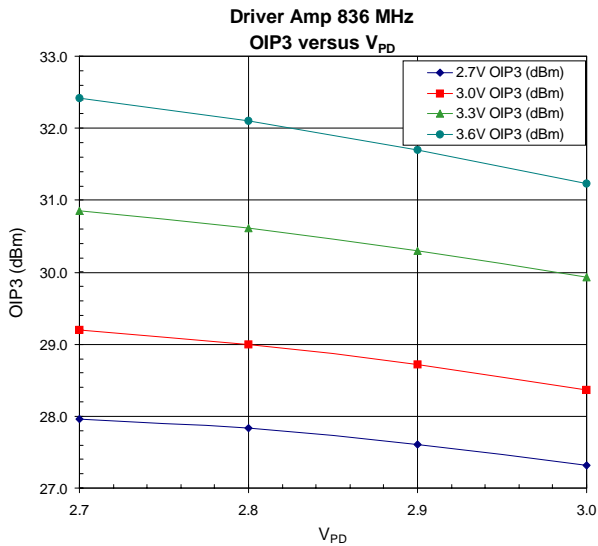
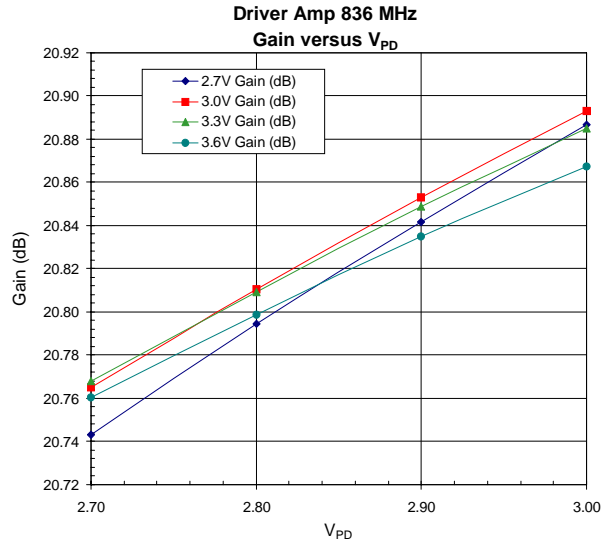
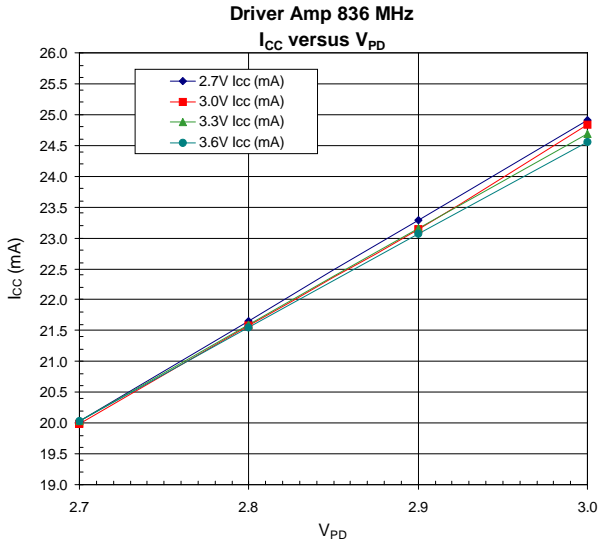

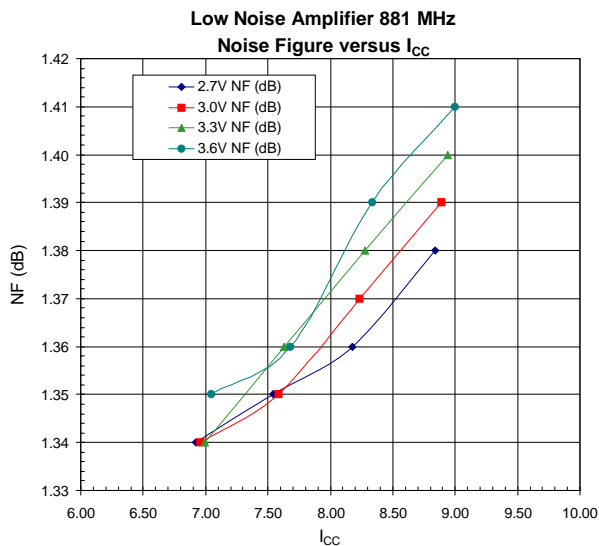
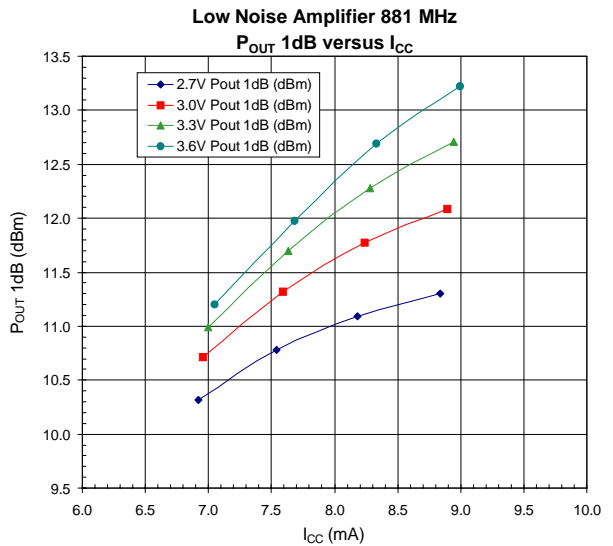
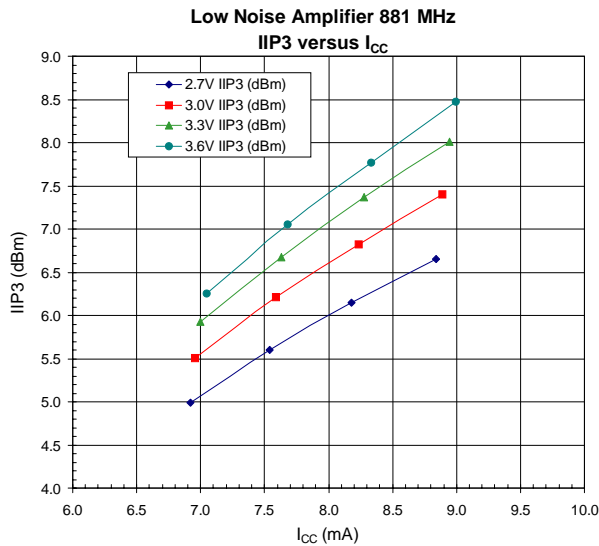
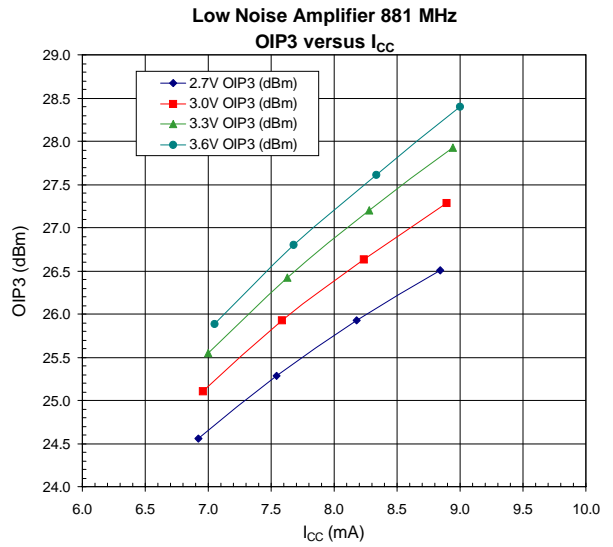
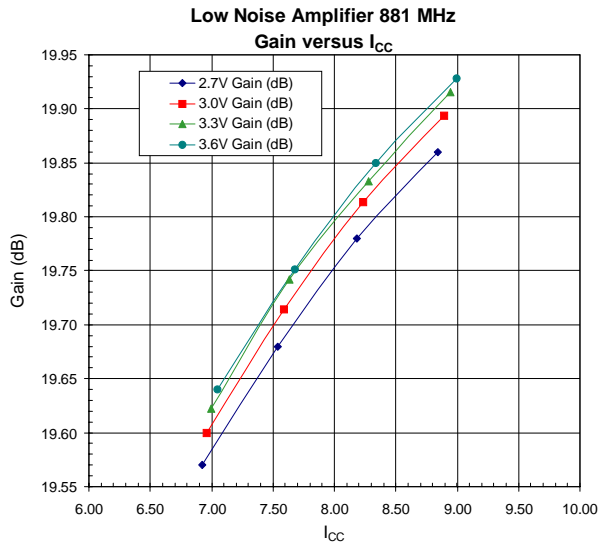

PCB Design Requirements

PCB Surface Finish

The PCB surface finish used for RFMD's qualification process is electroless nickel, immersion gold. Typical thickness is 3µinch to 8µinch gold over 180µinch nickel.

PCB Land Pattern Recommendation

PCB land patterns are based on IPC-SM-782 standards when possible. The pad pattern shown has been developed and tested for optimized assembly at RFMD; however, it may require some modifications to address company specific assembly processes. The PCB land pattern has been developed to accommodate lead and package tolerances.

PCB Metal Land Pattern

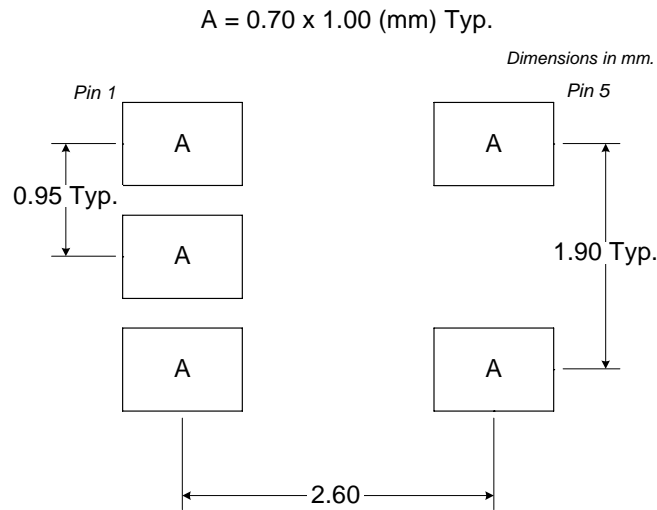

Figure 1. PCB Metal Land Pattern (Top View)

PCB Solder Mask Pattern

Liquid Photo-Imageable (LPI) solder mask is recommended. The solder mask footprint will match what is shown for the PCB metal land pattern with a 2mil to 3mil expansion to accommodate solder mask registration clearance around all pads. The center-grounding pad shall also have a solder mask clearance. Expansion of the pads to create solder mask clearance can be provided in the master data or requested from the PCB fabrication supplier.

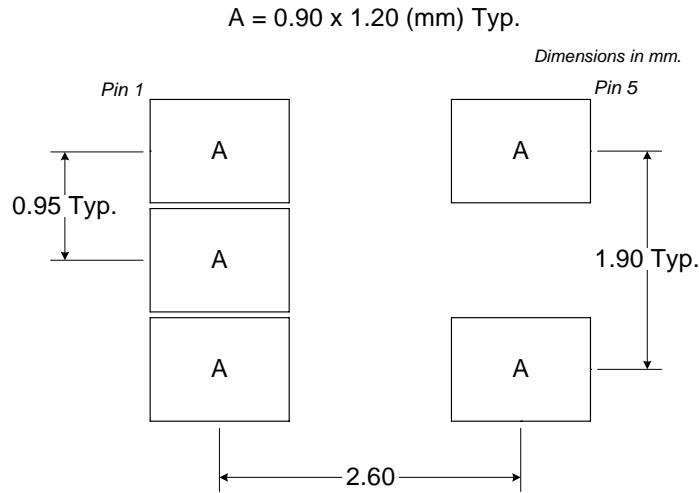

Figure 2. PCB Solder Mask (Top View)

RoHS* Banned Material Content

RoHS Compliant:	Yes
Package total weight in grams (g):	0.014
Compliance Date Code:	NA
Bill of Materials Revision:	-
Pb Free Category:	e3

Bill of Materials	Parts Per Million (PPM)					
	Pb	Cd	Hg	Cr VI	PBB	PBDE
Die	0	0	0	0	0	0
Molding Compound	0	0	0	0	0	0
Lead Frame	0	0	0	0	0	0
Die Attach Epoxy	0	0	0	0	0	0
Wire	0	0	0	0	0	0
Solder Plating	0	0	0	0	0	0

This RoHS banned material content declaration was prepared solely on information, including analytical data, provided to RFMD by its suppliers, and applies to the Bill of Materials (BOM) revision noted above.

* DIRECTIVE 2002/95/EC OF THE EUROPEAN PARLIAMENT AND OF THE COUNCIL of 27 January 2003 on the restriction of the use of certain hazardous substances in electrical and electronic equipment

