

**2.5V 16-Bit Universal Bus Driver
with 3-State Outputs**

Product Features

- PI74AVC+16334 is designed for low voltage operation, $V_{CC} = 1.65V$ to $3.6V$
- True $\pm 24mA$ Balanced Drive @ $3.3V$
- Compatible with Philips and T.I. AVC Logic family
- I_{OFF} supports partial power-down operation
- $3.6V$ I/O Tolerant inputs and outputs
- Meets PC133 SDRAM Registered DIMM specifications
- All outputs contain a patented DDC (Dynamic Drive Control) circuit that reduces noise without degrading propagation delay
- Industrial operation at $-40^{\circ}C$ to $+85^{\circ}C$
- Available Packages:
 - 48-pin 240-mil wide plastic TSSOP (A)
 - 48-pin 173-mil wide plastic TVSOP (K)

Product Description

Pericom Semiconductor's PI74AVC+ series of logic circuits are produced using the Company's advanced submicron CMOS technology, achieving industry leading speed.

The 16-bit PI74AVC+16334 universal bus driver is designed for $2.3V$ to $3.6V$ V_{CC} operation.

Data flow from A to Y is controlled by Output Enable (\overline{OE}). The device operates in the transparent mode when \overline{LE} is LOW. When \overline{LE} is HIGH, the A data is latched if CLK is held at a high or low logic level. If \overline{LE} is HIGH, the A-data is stored in the latch/flip-flop on the low-to-high transition of CLK. When \overline{OE} is HIGH, the outputs are in the high-impedance state.

To ensure the high-impedance state during power up or power down, \overline{OE} should be tied to V_{CC} through a pullup resistor; the minimum value of the resistor is determined by the current-sinking capability of the driver.

Logic Block Diagram

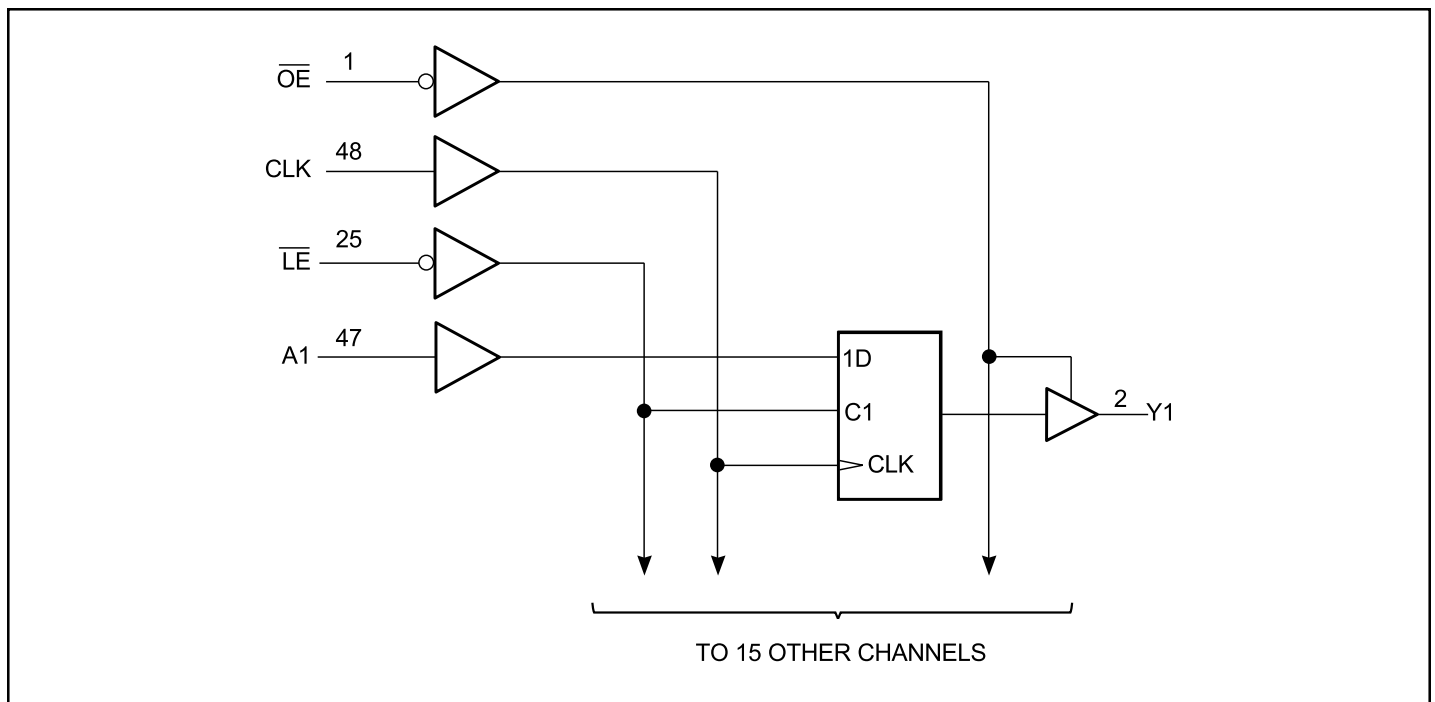

Maximum Ratings (Above which the useful life may be impaired. For user guidelines, not tested.)

Supply voltage range, V_{CC}	-0.5V to +4.6V
Input voltage range, V_I	-0.5V to +4.6V
Voltage range applied to any output in the high-impedance or power-off state, $V_O^{(1)}$	-0.5V to +4.6V
Voltage range applied to any output in the high or low state, $V_O^{(1,2)}$	-0.5V to $V_{CC}+0.5V$
Input clamp current, I_{IK} ($V_I < 0$)	-50mA
Output clamp current, I_{OK} ($V_O < 0$)	-50mA
Continuous output current, I_O	$\pm 50mA$
Continuous current through each V_{CC} or GND	$\pm 100mA$
Package thermal impedance, $\theta_{JA}^{(3)}$: package A	64°C/W
package K	48°C/W
Storage Temperature range, T_{stg}	-65°C to 150°C

Notes:
 Stresses greater than those listed under MAXIMUM RATINGS may cause permanent damage to the device. This is a stress rating only and functional operation of the device at these or any other conditions above those indicated in the operational sections of this specification is not implied. Exposure to absolute maximum rating conditions for extended periods may affect reliability.

1. Input & output negative-voltage ratings may be exceeded if the input and output current rating are observed.
2. Output positive-voltage rating may be exceeded up to 4.6V maximum if the output current rating is observed.
3. The package thermal impedance is calculated in accordance with JESD 51.

Product Pin Configuration

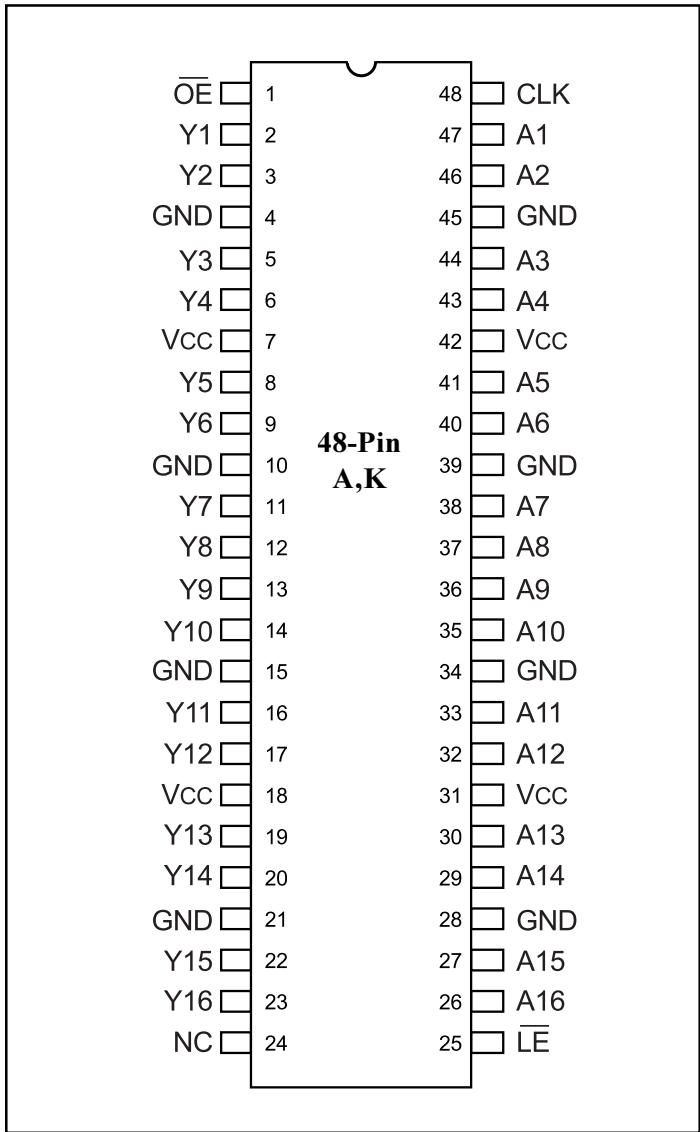

Product Pin Description

Pin Name	Description
\overline{OE}	Output Enable Input (Active LOW)
LE	Latch Enable (Active LOW)
CLK	Clock Input
A	Data Input
Y	Data Output
GND	Ground
VCC	Power

Truth Table⁽¹⁾

Inputs				Outputs Y
\overline{xOE}	LE	CLK	A	
H	X	X	X	Z
L	L	X	L	L
L	L	X	H	H
L	H	↑	L	L
L	H	↑	H	H
L	H	L or H	X	$Y_o^{(2)}$

Notes:

1. H = High Signal Level
 L = Low Signal Level
 ↑ = Transition LOW-to-HIGH
 X = Don't Care or Irrelevant
 Z = High Impedance
2. Output level before the indicated steady-state input conditions were established.

Recommended Operating Conditions⁽¹⁾

		Min.	Max.	Units
V _{CC} Supply Voltage	Operating	1.4	3.6	V
	Data retention only	1.2		
V _{IH} High-level Input Voltage	V _{CC} = 1.2V	V _{CC}		
	V _{CC} = 1.4V to 1.6V	0.65 x V _{CC}		
	V _{CC} = 1.65V to 1.95V	0.65 x V _{CC}		
	V _{CC} = 2.3V to 2.7V	1.7		
	V _{CC} = 3V to 3.6V	2		
V _{IL} Low-level Input Voltage	V _{CC} = 1.2V		GND	
	V _{CC} = 1.4V to 1.6V		0.35 x V _{CC}	
	V _{CC} = 1.65V to 1.95V		0.35 x V _{CC}	
	V _{CC} = 2.3V to 2.7V		0.7	
	V _{CC} = 3V to 3.6V		0.8	
V _I Input Voltage		0	3.6	
V _O Output Voltage	Active State	0	V _{CC}	
	3-State	0	3.6	
I _{OHS} High-level output current	V _{CC} = 1.4V to 1.6V		-4	mA
	V _{CC} = 1.65V to 1.95V		-6	
	V _{CC} = 2.3V to 2.7V		-12	
	V _{CC} = 3V to 3.6V		-24	
I _{OLS} Low-level output current	V _{CC} = 1.4V to 1.6V		4	
	V _{CC} = 1.65V to 1.95V		6	
	V _{CC} = 2.3V to 2.7V		12	
	V _{CC} = 3V to 3.6V		24	
ΔtΔv Input transition rise or fall rate	V _{CC} = 1.4V to 3.6V		5	ns/V
T _A Operating free-air temperature		-40	85	°C

Notes:

1. All unused inputs must be held at V_{CC} or GND to ensure proper device operation.

DC Electrical Characteristics (Over the Operating Range, $T_A = -40^\circ\text{C} + 85^\circ\text{C}$)

Parameters		Test Conditions ⁽¹⁾	V _{CC}	Min.	Typ.	Max.	Units
V _{OH}		I _{OH} = -100μA	1.4V to 3.6V	V _{CC} - 0.2V			V
		I _{OHS} = -4mA V _{IH} = 0.91V	1.4V	1.05			
		I _{OHS} = -6mA V _{IH} = 1.07V	1.65V	1.2			
		I _{OHS} = -12mA V _{IH} = 1.7V	2.3V	1.75			
		I _{OHS} = -24mA V _{IH} = 2V	3V	2.0			
V _{OL}		I _{OLS} = 100μA	1.4V to 3.6V			0.2	V
		I _{OLS} = 4mA V _{IL} = 0.49V	1.4V			0.4	
		I _{OLS} = 6mA V _{IL} = 0.57V	1.65V			0.45	
		I _{OLS} = 12mA V _{IL} = 0.7V	2.3V			0.55	
		I _{OLS} = 24mA V _{IL} = 0.8V	3V			0.8	
I _I	Control Inputs	V _I = V _{CC} or GND	3.6V			±2.5	μA
	I _{OFF}	V _I or V _O = 3.6V	0			±10	
	I _{OZ}	V _O = V _{CC} or GND	3.6V			±10	
	I _{CC}	V _I = V _{CC} or GND I _O = 0	3.6V			40	
C _I	Control Inputs	V _I = V _{CC} or GND	2.5V		3.5		pF
			3.3V		3.5		
	Data Inputs		2.5V		6		
			3.3V		6		
C _O	Outputs	V _O = V _{CC} or GND	2.5V		6.5		
			3.3V		6.5		

Note: Typical values are measured at $T_A = 25^\circ\text{C}$.

Operating Requirements over recommended operating free-air temperature range

(unless otherwise noted, see Figures 1 thru 4)

		V _{CC} = 1.2V		V _{CC} = 1.5V ± 0.1V		V _{CC} = 1.8V ± 0.15V		V _{CC} = 2.5V ± 0.2V		V _{CC} = 3.3V ± 0.3V		Units
		Min.	Max.	Min.	Max.	Min.	Max.	Min.	Max.	Min.	Max.	
f _{clock} Clock Frequency							150		150		150	MHz
t _w Pulse Duration	\overline{LE} low						3.3		3.3		3.3	ns
	CLK high or low						3.3		3.3		3.3	
t _{su} Setup Time	Data before CLK↑		1		0.8		0.7		0.7		0.7	
	Data before \overline{LE} ↑	CLK high	1.5		1.4		0.9		0.9		0.9	
		CLK low	2.7		1.6		1.2		1		1	
t _h Hold Time	Data after CLK↑		1.3		1.1		0.9		0.8		0.7	
t _h Hold Time	Data after \overline{LE} ↑	CLK high	2.2		1.9		1.7		1.5		1.5	
		CLK low	2.4		1.8		1.6		1.4		1.3	

Switching Characteristics over recommended operating free-air temperature range

(unless otherwise noted, see Figures 2 thru 5)

Parameter	From (Input)	To (Output)	V _{CC} = 1.2V		V _{CC} = 1.5V ± 0.1V		V _{CC} = 1.8V ± 0.15V		V _{CC} = 2.5V ± 0.2V		V _{CC} = 3.3V ± 0.3V		Units
			Typ.	Min.	Max.	Min.	Max.	Min.	Max.	Min.	Max.	Min.	
f _{max}							150		150		150		MHz
t _{pd}	A	Y	5.3	1.2	6.2	1.5	4.9	1	3.2	0.9	2.5	ns	
	\overline{LE}		7	2.2	9.7	1.8	7.5	1.5	4.9	0.8	4		
	CLK		6	1.9	7.8	1.6	6	1.1	3.7	1	3.1		
t _{en}	\overline{OE}		7.9	2.4	10.2	1.6	8.8	1.5	6.7	1	6.2		
t _{dis}	\overline{OE}		7.7	2.1	10.3	1.5	8.4	1.2	5.3	1	5.3		

Operating Characteristics, T_A = 25°C

Parameters		Test Conditions	V _{CC} = 1.8V ± 0.15V	V _{CC} = 2.5V ± 0.2V	V _{CC} = 3.3V ± 0.3V	Units
			Typical	Typical	Typical	
C _{pd} Power Dissipation Capacitance	Outputs Enabled	C _L = 0pF, f = 10 MHz	45	48	52	pF
	Outputs Disabled		23	25	28	

PARAMETER MEASUREMENT INFORMATION

$V_{CC} = 1.2V$ AND $1.5V \pm 0.1V$

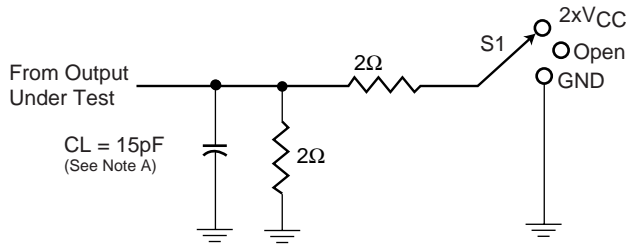

Load Circuit

Test	S1
t_{pd} t_{PLZ}/t_{PZL} t_{PHZ}/t_{PZH}	Open $2 \times V_{CC}$ GND

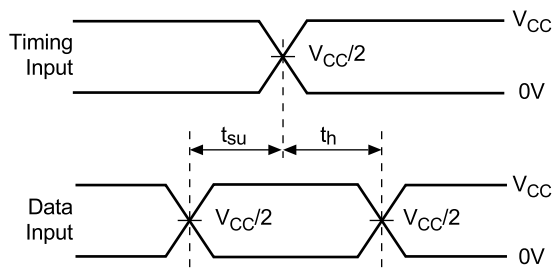

Voltage Waveforms
Setup and Hold Times

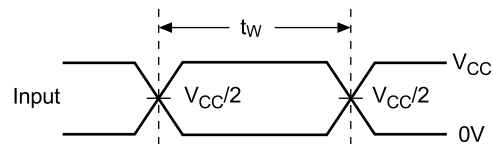

Voltage Waveforms
Pulse Duration

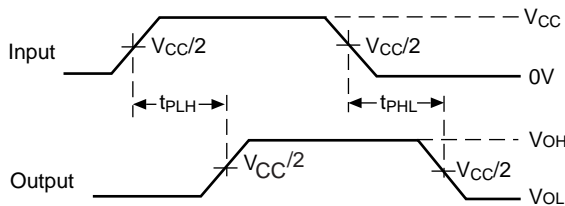

Voltage Waveforms
Propagation Delay Times

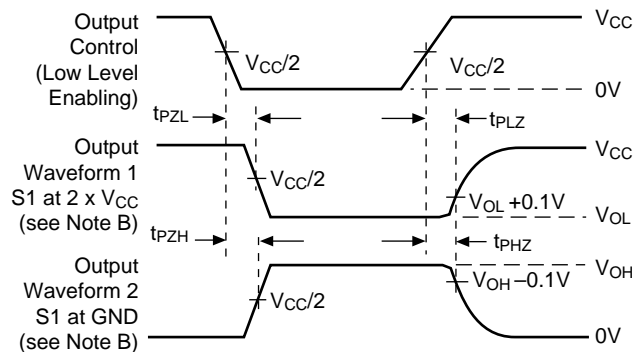

Voltage Waveforms
Enable and Disable Times

Figure 1. Load Circuit and Voltage Waveforms

Notes:

- A. C_L includes probe and jig capacitance.
- B. Waveform 1 is for an output with internal conditions such that the output is low except when disabled by the output control. Waveform 2 is for an output with internal conditions such that the output is high except when disabled by the output control.
- C. All input impulses are supplied by generators having the following characteristics: $PRR \leq 10$ MHz, $Z_O = 50\Omega$, $t_R \leq 2.0ns$, $t_F \leq 2.0ns$.
- D. The outputs are measured one at a time with one transition per measurement.
- E. t_{PLZ} and t_{PHZ} are the same as t_{dis}
- F. t_{PZL} and t_{PZH} are the same as t_{en}
- G. t_{PLH} and t_{PHL} are the same as t_{pd}

PARAMETER MEASUREMENT INFORMATION

$V_{CC} = 1.8V \pm 0.15V$

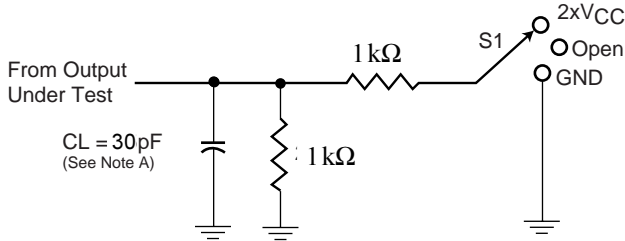

Load Circuit

Test	S1
t_{pd} t_{PLZ}/t_{PZL} t_{PHZ}/t_{PZH}	Open 2 x V_{CC} GND

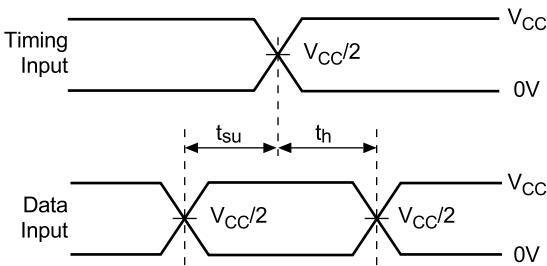

Voltage Waveforms
Setup and Hold Times

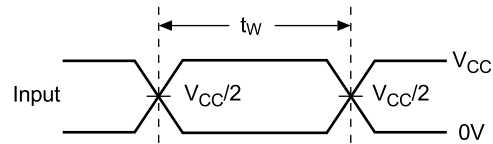

Voltage Waveforms
Pulse Duration

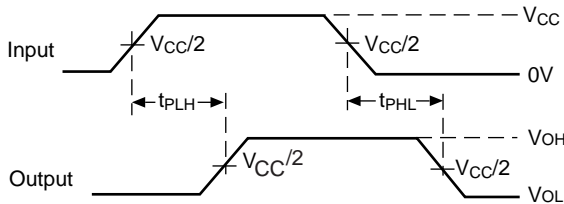

Voltage Waveforms
Propagation Delay Times

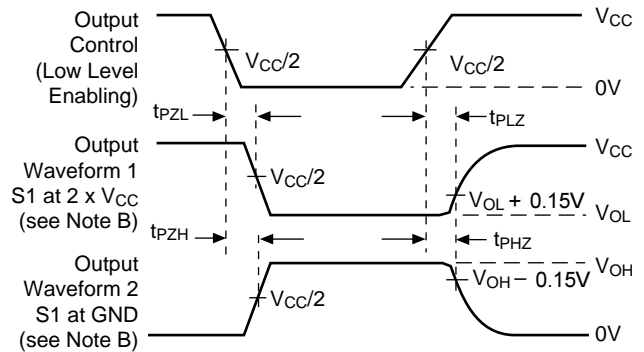

Voltage Waveforms
Enable and Disable Times

Figure 2. Load Circuit and Voltage Waveforms

Notes:

- A. C_L includes probe and jig capacitance.
- B. Waveform 1 is for an output with internal conditions such that the output is low except when disabled by the output control.
Waveform 2 is for an output with internal conditions such that the output is high except when disabled by the output control.
- C. All input impulses are supplied by generators having the following characteristics: $PRR \leq 10 \text{ MHz}$, $Z_O = 50\Omega$, $t_R \leq 2.0ns$, $t_F \leq 2.0ns$.
- D. The outputs are measured one at a time with one transition per measurement.
- E. t_{PLZ} and t_{PHZ} are the same as t_{dis}
- F. t_{PZL} and t_{PZH} are the same as t_{en}
- G. t_{PLH} and t_{PHL} are the same as t_{pd}

PARAMETER MEASUREMENT INFORMATION

$V_{CC} = 2.5V \pm 0.2V$

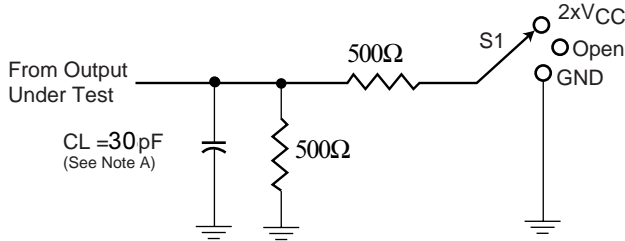

Load Circuit

Test	S1
t_{pd} t_{PLZ}/t_{PZL} t_{PHZ}/t_{PZH}	Open $2 \times V_{CC}$ GND

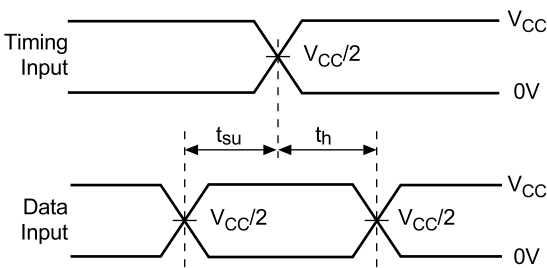

Voltage Waveforms
Setup and Hold Times

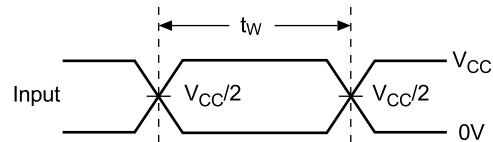

Voltage Waveforms
Pulse Duration

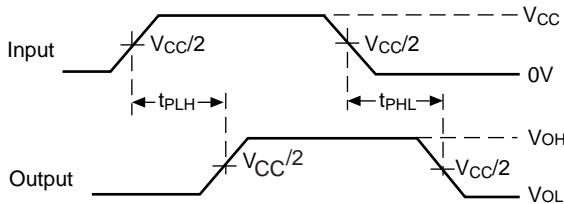

Voltage Waveforms
Propagation Delay Times

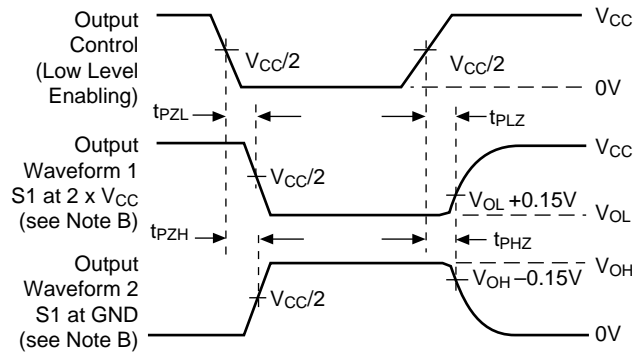

Voltage Waveforms
Enable and Disable Times

Figure 3. Load Circuit and Voltage Waveforms

Notes:

- A. C_L includes probe and jig capacitance.
- B. Waveform 1 is for an output with internal conditions such that the output is low except when disabled by the output control.
Waveform 2 is for an output with internal conditions such that the output is high except when disabled by the output control.
- C. All input impulses are supplied by generators having the following characteristics: $PRR \leq 10 \text{ MHz}$, $Z_O = 50\Omega$, $t_R \leq 2.0\text{ns}$, $t_F \leq 2.0\text{ns}$.
- D. The outputs are measured one at a time with one transition per measurement.
- E. t_{PLZ} and t_{PHZ} are the same as t_{dis}
- F. t_{PZL} and t_{PZH} are the same as t_{en}
- G. t_{PLH} and t_{PHL} are the same as t_{pd}

PARAMETER MEASUREMENT INFORMATION

$V_{CC} = 3.3V \pm 0.3V$

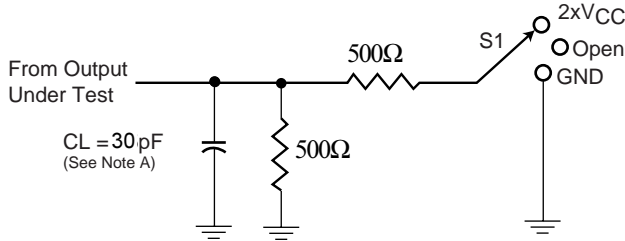

Load Circuit

Test	S1
t_{pd} t_{PLZ}/t_{PZL} t_{PHZ}/t_{PZH}	Open $2 \times V_{CC}$ GND

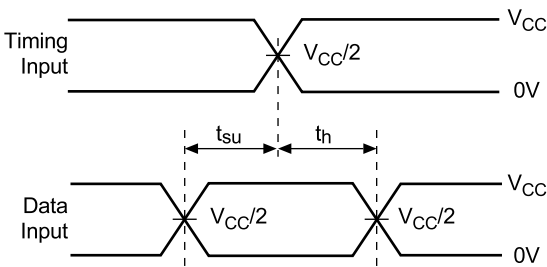

Voltage Waveforms
Setup and Hold Times

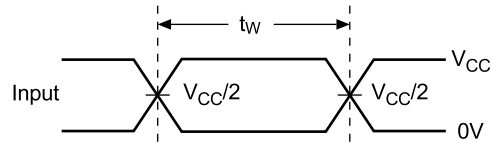

Voltage Waveforms
Pulse Duration

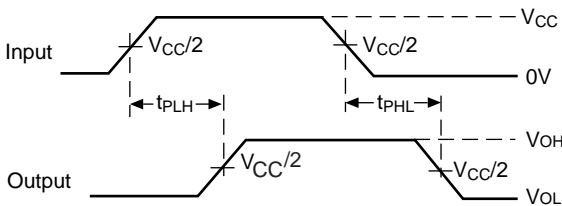

Voltage Waveforms
Propagation Delay Times

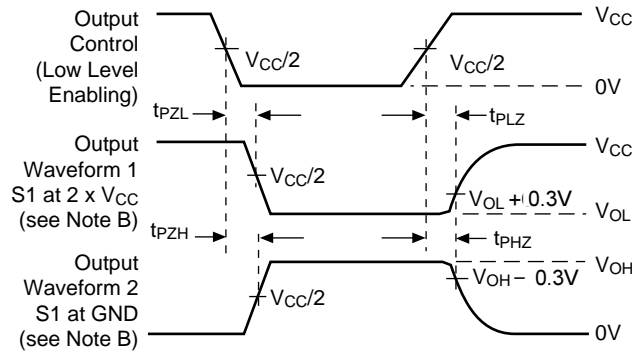

Voltage Waveforms
Enable and Disable Times

Figure 4. Load Circuit and Voltage Waveforms

Notes:

- A. C_L includes probe and jig capacitance.
- B. Waveform 1 is for an output with internal conditions such that the output is low except when disabled by the output control. Waveform 2 is for an output with internal conditions such that the output is high except when disabled by the output control.
- C. All input impulses are supplied by generators having the following characteristics: $PRR \leq 10 \text{ MHz}$, $Z_O = 50\Omega$, $t_R \leq 2.0\text{ns}$, $t_F \leq 2.0\text{ns}$.
- D. The outputs are measured one at a time with one transition per measurement.
- E. t_{PLZ} and t_{PHZ} are the same as t_{dis}
- F. t_{PZL} and t_{PZH} are the same as t_{en}
- G. t_{PLH} and t_{PHL} are the same as t_{pd}

Packaging Mechanical - 48-pin TSSOP (A-package)

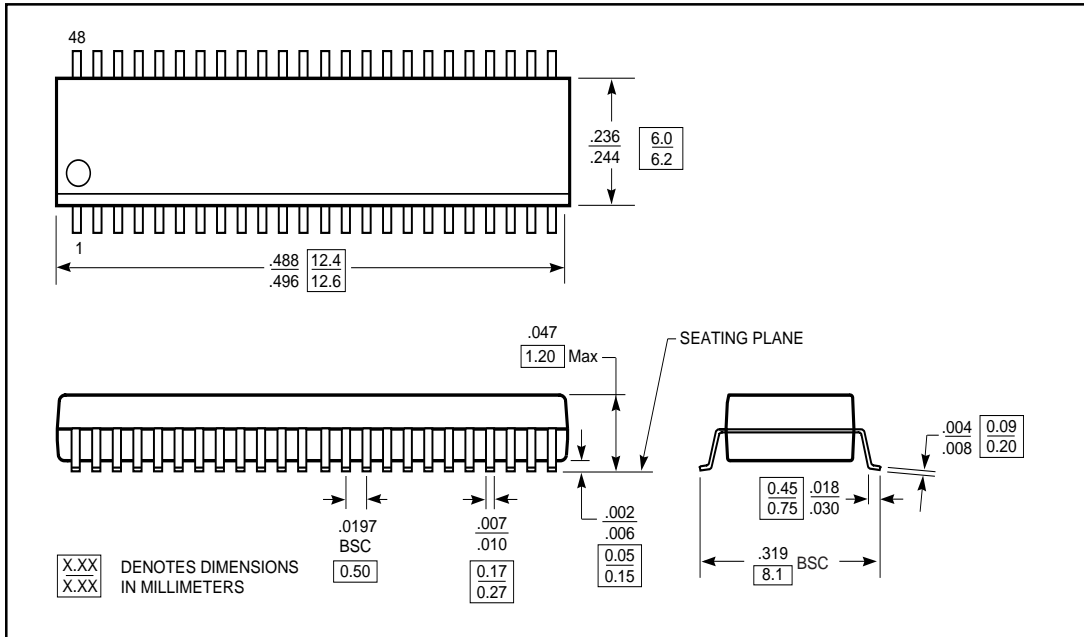

Packaging Mechanical - 48-pin TVSOP (TSSOP) (K-package)

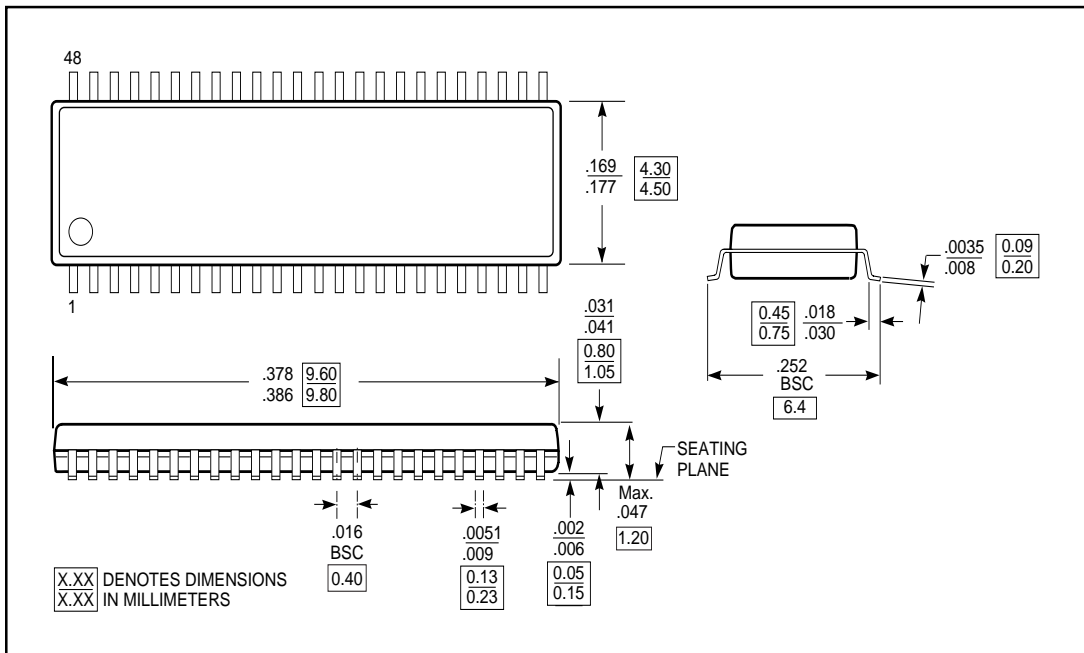

Ordering Information	Description
PI74AVC+16334A	48-pin, 240-mil wide plastic TSSOP
PI74AVC+16334K	48-pin, 173-mil wide plastic TVSOP