

Customer Information Sheet

DRAWING No.: M80-681XXXX

SHEET 2 OF 2

IF IN DOUBT - ASK

(C)

NOT TO SCALE

THIRD ANGLE PROJECTION

ALL DIMENSIONS IN mm

ASSEMBLY PART No.	No. OF CONTACTS	DIM 'X'	DIM 'Y'
M80-68104XX	4	2.00	7.15
M80-68106XX	6	4.00	9.15
M80-68108XX	8	6.00	11.15
M80-68110XX	10	8.00	13.15
M80-68112XX	12	10.00	15.15
M80-68114XX	14	12.00	17.15
M80-68116XX	16	14.00	19.15
M80-68118XX	18	16.00	21.15
M80-68120XX	20	18.00	23.15
M80-68126XX	26	24.00	29.15
M80-68134XX	34	32.00	37.15
M80-68144XX	44	42.00	47.15

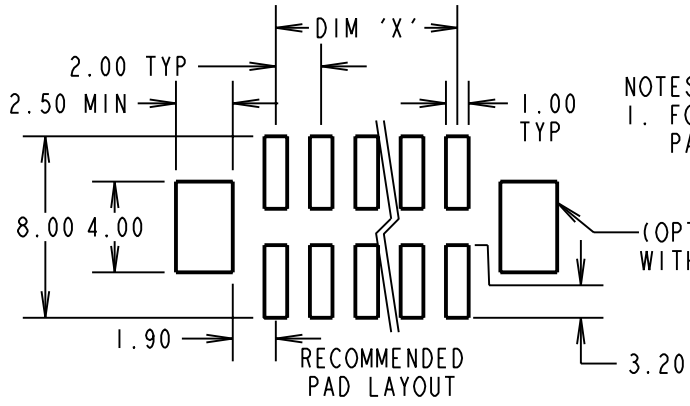
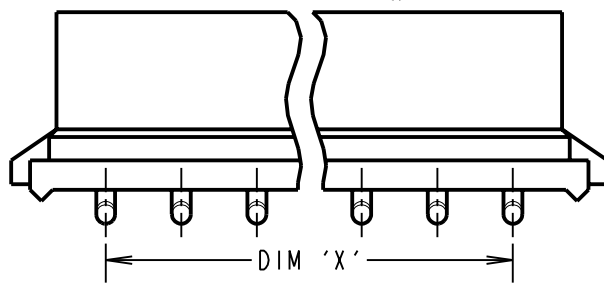
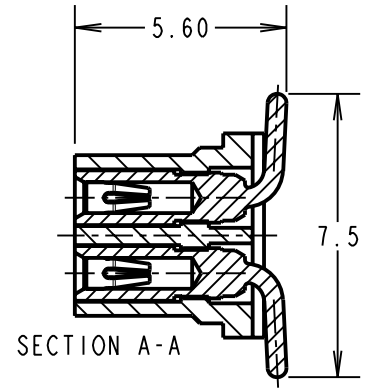
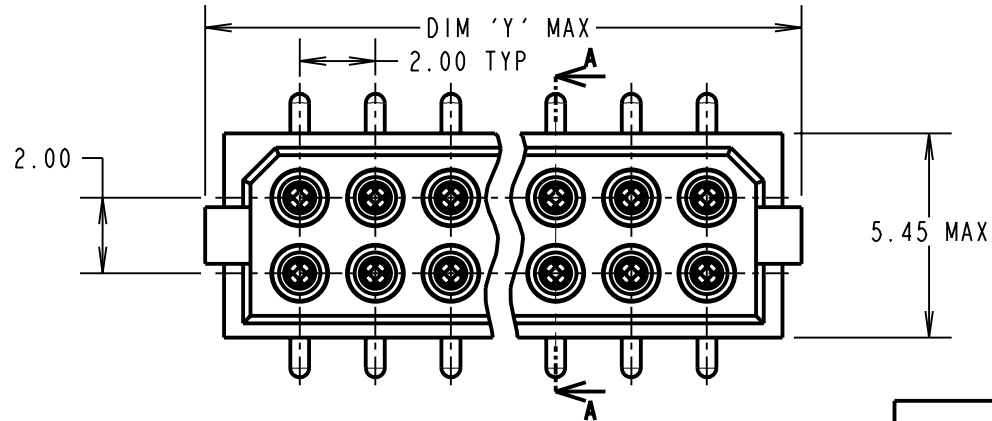

ORDER CODE:
M80-681XXXX

TOTAL No. OF CONTACTS
 04, 06, 08, 10, 12, 14,
 16, 18, 20, 26, 34, 44

FINISH
 01 - GOLD CLIP, TIN/LEAD SHELL
 42 - GOLD CLIP, 100% TIN SHELL
 45 - GOLD CLIP, GOLD SHELL

SPECIFICATIONS:

MATERIAL:
 MOULDING = GLASS-FILLED POLYAMIDE 46, UL94V-0, BLACK
 CONTACT CLIP = BERYLLIUM COPPER
 CONTACT SHELL = BRASS

FINISH:
 01 = 0.3µ GOLD CLIP, 4µ TIN/LEAD SHELL
 42 = 0.3µ GOLD CLIP, 4µ 100% TIN SHELL
 45 = 0.3µ GOLD CLIP, 0.3µ GOLD SHELL

ELECTRICAL:
 CURRENT RATING AT 25°C = 3.0A MAX
 CURRENT RATING AT 85°C = 2.2A MAX
 WORKING VOLTAGE = 120V AC/DC
 VOLTAGE PROOF = 360V AC/DC
 CONTACT RESISTANCE = 25 mΩ MAX
 INSULATION RESISTANCE = 100 MΩ MIN

MECHANICAL:
 DURABILITY = 500 OPERATIONS
 INSERTION FORCE = 2.8N MAX, 1.0N MIN
 WITHDRAWAL FORCE = 1.8N MAX, 0.2N MIN

ENVIRONMENTAL:
 TEMPERATURE RANGE = -55°C TO +125°C
PACKING:
 TUBE

NOTES:
 1. FOR CONNECTOR WITH PICK AND PLACE PAD, SEE DRAWING M80-681XXXXP.

(OPTIONAL) HOLES REQUIRED FOR USE WITH LATCHED MALE CONNECTORS.

RA	3	19.01.10	10649
NAME	ISS.	DATE	C/NOTE
APPROVED:		R. ADDE	
CHECKED:		M.G.PLESTED	
DRAWN:		W. J. BOURNE	
CUSTOMER REF.:			
ASSEMBLY DRG:			



HARWIN USA
 TEL: 603 893 5376
 FAX: 603 893 5396
 mis@harwin.com

HARWIN Europe (UK)
 TEL: 023 9231 4545
 FAX: 023 9231 4590
 mis@harwin.co.uk

HARWIN Asia
 TEL: +65 6 779 4909
 FAX: +65 6 779 3868
 mis@harwin.com.sg

THIS DRAWING AND ANY INFORMATION OR DESCRIPTIVE MATTER SET OUT HEREON ARE CONFIDENTIAL AND COPYRIGHT PROPERTY OF THE HARWIN GROUP AND MUST NOT BE DISCLOSED, LOANED, COPIED OR USED FOR MANUFACTURING, TENDERING OR FOR ANY OTHER PURPOSE WITHOUT THEIR WRITTEN PERMISSION.

TOLERANCES
 X. = ±1mm
 X.X = ±0.25mm
 X.XX = ±0.10mm
 X.XXX = ±0.01mm
 ANGLES = ±5°
 UNLESS STATED

MATERIAL:
 SEE ABOVE

FINISH:
 SEE ABOVE

S/AREA:
 mm²

TITLE:
 DATAMATE DIL VERTICAL SMT SOCKET ASSEMBLY

DRAWING NUMBER:
M80-681XXXX

SHT 2 OF 2