

Low Quiescent Current High Efficiency Step-Down Converters

FEATURES

- High Efficiency: Over 92% Possible
- **Very Low Standby Current: 10 μ A Typ**
- **Available in Space Saving 8-Lead MSOP Package**
- Internal 1.4 Ω Power Switch ($V_{IN} = 10V$)
- Wide V_{IN} Range: 3V to 18V Operation
- Very Low Dropout Operation: 100% Duty Cycle
- Low-Battery Detector Functional During Shutdown
- Programmable Current Limit with Optional Current Sense Resistor (10mA to 400mA)
- Short-Circuit Protection
- Few External Components Required
- Active Low Micropower Shutdown: $I_Q = 6\mu A$ Typ
- Pushbutton On/Off (LTC1475 Only)

APPLICATIONS

- Cellular Telephones and Wireless Modems
- 4mA to 20mA Current Loop Step-Down Converter
- Portable Instruments
- Battery-Operated Digital Devices
- Battery Chargers
- Inverting Converters
- Intrinsic Safety Applications

DESCRIPTION

The LTC[®]1474/LTC1475 are high efficiency step-down converters with internal P-channel MOSFET power switches that draw only 10 μ A typical DC supply current at no load while maintaining output voltage. The low supply current coupled with Burst Mode™ operation enables the LTC1474/LTC1475 to maintain high efficiency over a wide range of loads. These features, along with their capability of 100% duty cycle for low dropout and wide input supply range, make the LTC1474/LTC1475 ideal for moderate current (up to 300mA) battery-powered applications.

The peak switch current is user-programmable with an optional sense resistor (defaults to 400mA if not used) providing a simple means for optimizing the design for lower current applications. The peak current control also provides short-circuit protection and excellent start-up behavior. A low-battery detector that remains functional in shutdown is provided.

The LTC1474/LTC1475 availability in 8-lead MSOP and SO packages and need for few additional components provide for a minimum area solution.

LT, LTC and LT are registered trademarks of Linear Technology Corporation. Burst Mode is a trademark of Linear Technology Corporation.

4

TYPICAL APPLICATION

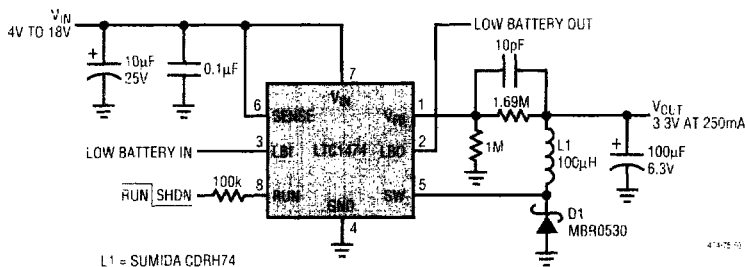
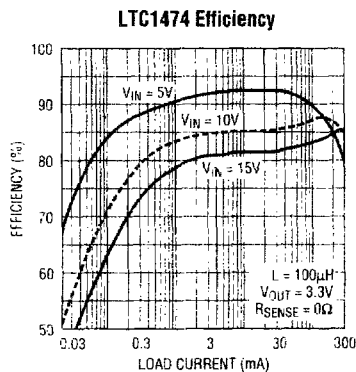

Figure 1. High Efficiency Step-Down Converter



LTC1474/LTC1475

ABSOLUTE MAXIMUM RATINGS

Input Supply Voltage (V_{IN}) -0.3V to 20V
 Switch Current (SW, SENSE) 750mA
 Switch Voltage (SW) ($V_{IN}-20V$) to ($V_{IN}+0.3V$)
 V_{FB} (Adjustable Versions) -0.3V to 12V
 RUN, LBI, LBO, SENSE -0.3V to 20V

Operating Ambient Temperature Range
 Commercial 0°C to 70°C
 Industrial -40°C to 85°C
 Junction Temperature (Note 1) 125°C
 Storage Temperature Range -65°C to 150°C
 Lead Temperature (Soldering, 10 sec) 300°C

PACKAGE/ORDER INFORMATION

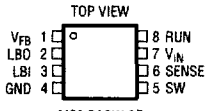
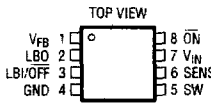
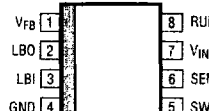
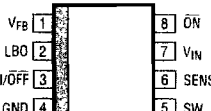
 <p>MS8 PACKAGE 8-LEAD PLASTIC MSOP</p> <p>$T_{JMAX} = 125^{\circ}C$, $\theta_{JA} = 150^{\circ}C/W$</p>	 <p>MS8 PACKAGE 8-LEAD PLASTIC MSOP</p> <p>$T_{JMAX} = 125^{\circ}C$, $\theta_{JA} = 150^{\circ}C/W$</p>	 <p>S8 PACKAGE 8-LEAD PLASTIC SO</p> <p>$T_{JMAX} = 125^{\circ}C$, $\theta_{JA} = 110^{\circ}C/W$</p>	 <p>S8 PACKAGE 8-LEAD PLASTIC SO</p> <p>$T_{JMAX} = 125^{\circ}C$, $\theta_{JA} = 110^{\circ}C/W$</p>
ORDER PART NUMBER	ORDER PART NUMBER	ORDER PART NUMBER	ORDER PART NUMBER
LTC1474CMS8	LTC1475CMS8	LTC1474CS8 LTC1474IS8	LTC1475CS8 LTC1475IS8
MS8 PART MARKING	MS8 PART MARKING	S8 PART MARKING	S8 PART MARKING
LTBW	LTBK	1474 1474I	1475 1475I

Consult factory for Military grade parts.

ELECTRICAL CHARACTERISTICS $T_A = 25^{\circ}C$, $V_{IN} = 10V$, $V_{RUN} = open$, $R_{SENSE} = 0$, unless otherwise noted.

SYMBOL	PARAMETER	CONDITIONS	MIN	TYP	MAX	UNITS
V_{FB}	Feedback Voltage	$I_{LOAD} = 50mA$	● 1.205	1.230	1.255	V
I_{FB}	Feedback Current		●	0	30	nA
I_{SUPPLY}	No Load Supply Current (Note 3)	$I_{LOAD} = 0$ (Figure 1 Circuit)		10		μA
ΔV_{OUT}	Output Voltage Line Regulation	$V_{IN} = 7V$ to 12V, $V_{OUT} = 3.3V$, $I_{LOAD} = 50mA$		1	20	mV
	Output Voltage Load Regulation	$I_{LOAD} = 0mA$ to 50mA		2.5	15	mV
	Output Ripple	$I_{LOAD} = 10mA$		50		mV _{p-p}
I_Q	Input DC Supply Current (Note 2) Active Mode (Switch On) Sleep Mode (Note 3) Shutdown	(Exclusive of Driver Gate Charge Current)		100	175	μA
		$V_{IN} = 3V$ to 18V		9	15	μA
		$V_{IN} = 3V$ to 18V		6	12	μA
		$V_{IN} = 3V$ to 18V, $V_{RUN} = 0V$				
R_{ON}	Switch Resistance	$I_{SW} = 100mA$		1.4	1.6	Ω
I_{PEAK}	Current Comp Max Current Trip Threshold	$R_{SENSE} = 0\Omega$	325	400		mA
		$R_{SENSE} = 1.1\Omega$	70	76	85	mA
V_{SENSE}	Current Comp Sense Voltage Trip Threshold		● 90	100	110	mV

ELECTRICAL CHARACTERISTICS $T_A = 25^\circ\text{C}$, $V_{IN} = 10\text{V}$, $V_{RUN} = \text{open}$, $R_{SENSE} = 0$, unless otherwise noted.

SYMBOL	PARAMETER	CONDITIONS	MIN	TYP	MAX	UNITS
V_{HYST}	Voltage Comparator Hysteresis			5		mV
t_{OFF}	Switch Off-Time	V_{OUT} at Regulated Value $V_{OUT} = 0\text{V}$	3.5	4.75 65	6.0	μs μs
$V_{LBI, TRIP}$	Low Battery Comparator Threshold		● 1.10	1.23	1.35	V
V_{RUN}	Run/ON Pin Threshold		0.4	0.7	1.0	V
$V_{LBI, OFF}$	OFF Pin Threshold (LTC1475 Only)		0.4	0.7	1.0	V
$I_{LBO, SINK}$	Sink Current into Pin 2	$V_{LBI} = 0\text{V}$, $V_{LBO} = 0.4\text{V}$	0.45	0.70		mA
$I_{RUN, SOURCE}$	Source Current from Pin 8	$V_{RUN} = 0\text{V}$	0.4	0.8	1.2	μA
$I_{SW, LEAK}$	Switch Leakage Current	$V_{IN} = 18\text{V}$, $V_{SW} = 0\text{V}$, $V_{RUN} = 0\text{V}$		0.015	1	μA
$I_{LBI, LEAK}$	Leakage Current into Pin 3	$V_{LBI} = 18\text{V}$, $V_{IN} = 18\text{V}$		0	0.1	μA
$I_{LBO, LEAK}$	Leakage Current into Pin 2	$V_{LBI} = 2\text{V}$, $V_{LBO} = 5\text{V}$		0	0.5	μA

The ● denotes specifications which apply over the full operating temperature range.

Note 1: T_J is calculated from the ambient temperature T_A and power dissipation P_D according to the following formulas:

$$\text{LTC1474CS8/LTC1475CS8: } T_J = T_A + (P_D \cdot 110^\circ\text{C/W})$$

$$\text{LTC1474CMS8/LTC1475CMS8: } T_J = T_A + (P_D \cdot 150^\circ\text{C/W})$$

Note 2: Dynamic supply current is higher due to the gate charge being delivered at the switching frequency. See Applications Information.

Note 3: No load supply current consists of sleep mode DC current (9 μA typical) plus a small switching component (about 1 μA for Figure 1 circuit) necessary to overcome Schottky diode and feedback resistor leakage.

TYPICAL PERFORMANCE CHARACTERISTICS

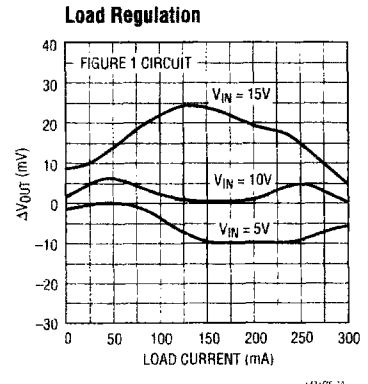
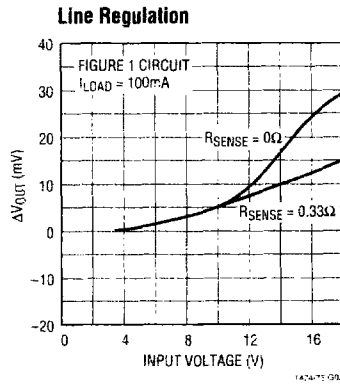
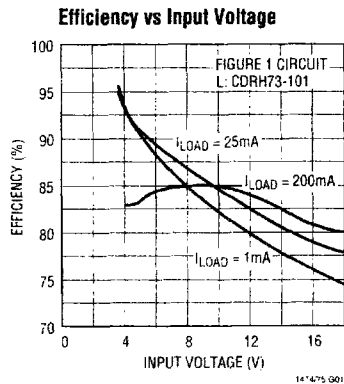

TYPICAL PERFORMANCE CHARACTERISTICS

Current Trip Threshold vs Temperature

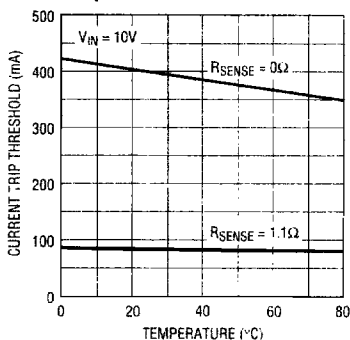

Switch Resistance vs Input Voltage

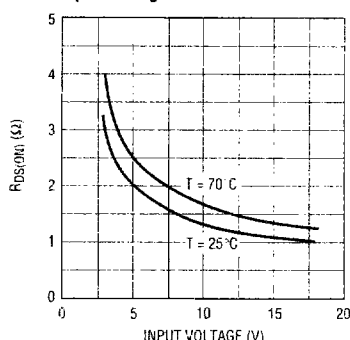

Supply Current in Shutdown

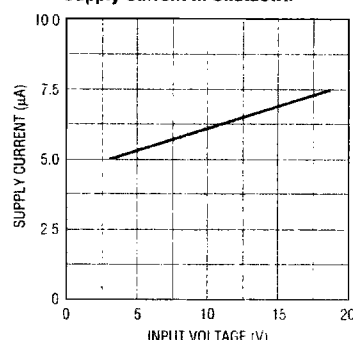

Switch Leakage Current vs Temperature

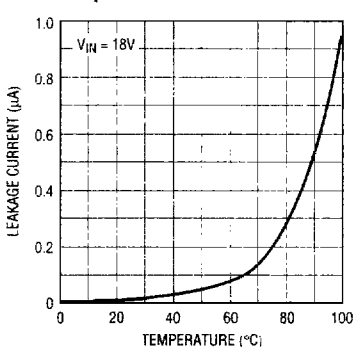
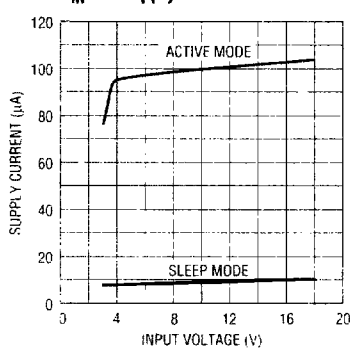
 V_{IN} DC Supply Current

Off-Time vs Output Voltage

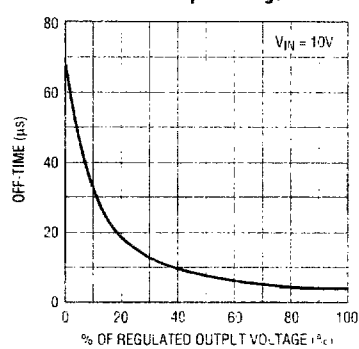

PIN FUNCTIONS

V_{FB} (Pin 1): Feedback of Output Voltage for Comparison to Internal 1.23V Reference. An external resistive divider must be used to divide the output voltage down to the reference level.

LBO (Pin 2): Open Drain Output of the Low Battery Comparator. This pin will sink current when Pin 3 is below 1.23V.

LBI/ \overline{OFF} (Pin 3): Input to Low Battery Comparator. This input is compared to the internal 1.23V reference. For the LTC1475, a momentary ground on this pin puts regulator in shutdown mode.

GND (Pin 4): Ground Pin.

SW (Pin 5): Drain of Internal PMOS Power Switch. Cathode of Schottky diode must be closely connected to this pin.

SENSE (Pin 6): Current Sense Input for Monitoring Switch Current and Source of Internal PMOS Power Switch. Maximum switch current is programmed with a resistor between SENSE and V_{IN} pins.

V_{IN} (Pin 7): Main Supply Pin.

RUN/ \overline{ON} (Pin 8): On LTC1474, voltage level on this pin controls shutdown/run mode (ground = shutdown, open/high = run). On LTC1475, a momentary ground on this pin puts regulator in run mode. A 100k series resistor must be used between Pin 8 and the switch or control voltage.

FUNCTIONAL DIAGRAM

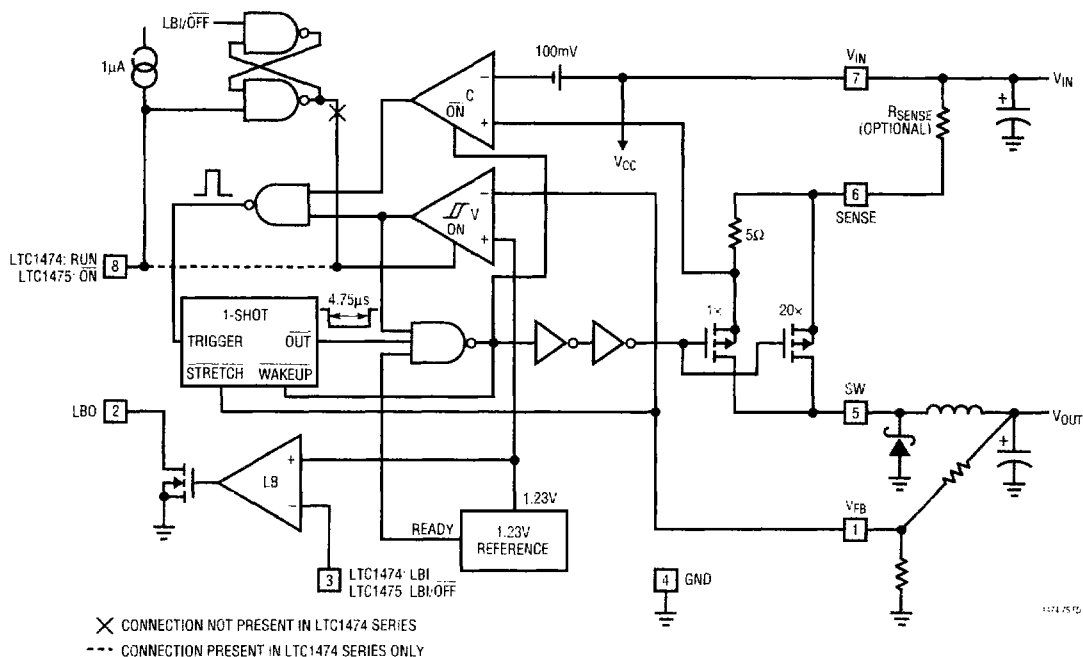

4

OPERATION (Refer to Functional Diagram)

The LTC1474/LTC1475 are step-down converters with internal power switches that use Burst Mode operation to keep the output capacitor charged to the proper output voltage while minimizing the quiescent current. Burst Mode operation functions by using short “burst” cycles to ramp the inductor current through the internal power switch and external Schottky diode, followed by a sleep cycle where the power switch is off and the load current is supplied by the output capacitor. During sleep mode, the LTC1474/LTC1475 draw only 9 μ A typical supply current. At light loads, the burst cycles are a small percentage of the total cycle time; thus the average supply current is very low, greatly enhancing efficiency.

Burst Mode Operation

At the beginning of the burst cycle, the switch is turned on and the inductor current ramps up. At this time, the internal current comparator is also turned on to monitor the switch

current by measuring the voltage across the internal and optional external current sense resistors. When this voltage reaches 100mV, the current comparator trips and pulses the 1-shot timer to start a 4.75 μ s off-time during which the switch is turned off and the inductor current ramps down. At the end of the off-time, if the output voltage is less than the voltage comparator threshold, the switch is turned back on and another cycle commences. To minimize supply current, the current comparator is turned on only during the switch-on period when it is needed to monitor switch current. Likewise, the 1-shot timer will only be on during the 4.75 μ s off-time period.

The average inductor current during a burst cycle will normally be greater than the load current, and thus the output voltage will slowly increase until the internal voltage comparator trips. At this time, the LTC1474/LTC1475 go into sleep mode, during which the power switch is off and only the minimum required circuitry is left on: the

OPERATION (Refer to Functional Diagram)

voltage comparator, reference and low battery comparator. During sleep mode, with the output capacitor supplying the load current, the V_{FB} voltage will slowly decrease until it reaches the lower threshold of the voltage comparator (about 5mV below the upper threshold). The voltage comparator then trips again, signaling the LTC1474/LTC1475 to turn on the circuitry necessary to begin a new burst cycle.

Peak Inductor Current Programming

The current comparator provides a means for programming the maximum inductor/switch current for each switch cycle. The 1X sense MOSFET, a portion of the main power MOSFET, is used to divert a sample (about 5%) of the switch current through the internal 5Ω sense resistor. The current comparator monitors the voltage drop across the series combination of the internal and external sense resistors and trips when the voltage exceeds 100mV. If the external sense resistor is not used (Pins 6 and 7 shorted), the current threshold defaults to the 400mA maximum due to the internal sense resistor.

Off-Time

The off-time duration is $4.75\mu\text{s}$ when the feedback voltage is close to the reference; however, as the feedback voltage drops, the off-time lengthens and reaches a maximum

value of about $65\mu\text{s}$ when this voltage is zero. This ensures that the inductor current has enough time to decay when the reverse voltage across the inductor is low such as during short circuit.

Shutdown Mode

Both LTC1474 and LTC1475 provide a shutdown mode that turns off the power switch and all circuitry except for the low battery comparator and 1.23V reference, further reducing DC supply current to $6\mu\text{A}$ typical. The LTC1474's run/shutdown mode is controlled by a voltage level at the RUN pin (ground = shutdown, open/high = run). The LTC1475's run/shutdown mode, on the other hand, is controlled by an internal S/R flip-flop to provide pushbutton on/off control. The flip-flop is set (run mode) by a momentary ground at the $\overline{\text{ON}}$ pin and reset (shutdown mode) by a momentary ground at the LBI/OFF pin.

Low Battery Comparator

The low battery comparator compares the voltage on the LBI pin to the internal reference and has an open drain N-channel MOSFET at its output. If LBI is above the reference, the output FET is off and the LBO output is high impedance. If LBI is below the reference, the output FET is on and sinks current. The comparator is still active in shutdown.

APPLICATIONS INFORMATION

The basic LTC1474/LTC1475 application circuit is shown in Figure 1, a high efficiency step-down converter. External component selection is driven by the load requirement and begins with the selection of R_{SENSE} . Once R_{SENSE} is known, L can be chosen. Finally D1, C_{IN} and C_{OUT} are selected.

R_{SENSE} Selection

The current sense resistor (R_{SENSE}) allows the user to program the maximum inductor/switch current to optimize the inductor size for the maximum load. The LTC1474/LTC1475 current comparator has a maximum threshold of $100\text{mV}/(R_{\text{SENSE}} + 0.25)$. The maximum average output current I_{MAX} is equal to this peak value less half the peak-to-peak ripple current ΔI_L .

Allowing a margin for variations in the LTC1474/LTC1475 and external components, the required R_{SENSE} can be calculated from Figure 2 and the following equation:

$$R_{\text{SENSE}} = (0.067/I_{\text{MAX}}) - 0.25 \quad (1)$$

for $10\text{mA} < I_{\text{MAX}} < 200\text{mA}$.

For I_{MAX} above 200mA, R_{SENSE} is set to zero by shorting Pins 6 and 7 to provide the maximum peak current of 400mA (limited by the fixed internal sense resistor). This 400mA default peak current can be used for lower I_{MAX} if desired to eliminate the need for the sense resistor and associated decoupling capacitor. However, for optimal performance, the peak inductor current should be set to no more than what is needed to meet the load current requirements. Lower peak currents have the advantage of lower

APPLICATIONS INFORMATION

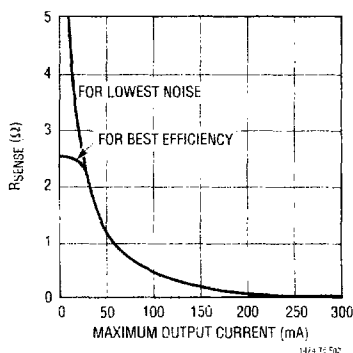
Figure 2. R_{SENSE} Selection

output ripple ($\Delta V_{OUT} = I_{PEAK} \cdot ESR$), lower noise, and less stress on alkaline batteries and other circuit components. Also, lower peak currents allow the use of inductors with smaller physical size.

Peak currents as low as 10mA can be programmed with the appropriate sense resistor. Increasing R_{SENSE} above 10Ω , however, gives no further reduction of I_{PEAK} .

For R_{SENSE} values less than 1Ω , it is recommended that the user parallel standard resistors (available in values $\geq 1\Omega$) instead of using a special low valued shunt resistor. Although a single resistor could be used with the desired value, these low valued shunt resistor types are much more expensive and are currently not available in case sizes smaller than 1206. Three or four 0603 size standard resistors require about the same area as one 1206 size current shunt resistor at a fraction of the cost.

At higher supply voltages and lower inductances, the peak currents may be slightly higher due to current comparator overshoot and can be predicted from the second term in the following equation:

$$I_{PEAK} = \frac{0.1}{0.25 + R_{SENSE}} + \frac{(2.5)(10^{-7})(V_{IN} - V_{OUT})}{L} \quad (2)$$

Note that R_{SENSE} only sets the maximum inductor current peak. At lower di/dt (lower input voltages and higher inductances), the observed peak current at loads less than I_{MAX} may be less than this calculated peak value due to the voltage comparator tripping before the current ramps up

high enough to trip the current comparator. This effect improves efficiency at lower loads by keeping the I^2R losses down (see Efficiency Considerations section).

Inductor Value Selection

Once R_{SENSE} and I_{PEAK} are known, the inductor value can be determined. The minimum inductance recommended as a function of I_{PEAK} and I_{MAX} can be calculated from:

$$L_{MIN} \geq \left[\frac{0.75(V_{OUT} + V_D)t_{OFF}}{I_{PEAK} - I_{MAX}} \right] \quad (3)$$

where $t_{OFF} = 4.75\mu s$.

If the L_{MIN} calculated is not practical, a larger I_{PEAK} should be used. Although the above equation provides the minimum, better performance (efficiency, line/load regulation, noise) is usually gained with higher values. At higher inductances, peak current and frequency decrease (improving efficiency) and inductor ripple current decreases (improving noise and line/load regulation). For a given inductor type, however, as inductance is increased, DC resistance (DCR) increases, increasing copper losses and current rating decreases, both effects placing an upper limit on the inductance. The recommended range of inductances for small surface mount inductors as a function of peak current is shown in Figure 3. The values in this range are a good compromise between the trade-offs discussed above. If space is not a premium, inductors with larger cores can be used, which extends the recommended range of Figure 3 to larger values.

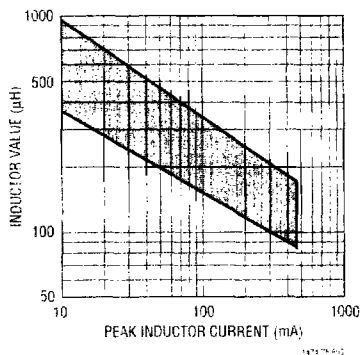

Figure 3. Recommended Inductor Values

APPLICATIONS INFORMATION

Inductor Core Selection

Once the value of L is known, the type of inductor must be selected. High efficiency converters generally cannot afford the core loss found in low cost powdered iron cores, forcing the use of more expensive ferrite, molypermalloy or Kool M μ [®] cores. Actual core loss is independent of core size for a fixed inductor value, but is very dependent on inductance selected. As inductance increases, core losses go down. Unfortunately, as discussed in the previous section, increased inductance requires more turns of wire and therefore copper losses will increase.

Ferrite and Kool M μ designs have very low core loss and are preferred at high switching frequencies, so design goals can concentrate on copper loss and preventing saturation. Ferrite core material saturates "hard," which means that inductance collapses abruptly when the peak design current is exceeded. This results in an abrupt increase in inductor current above I_{PEAK} and consequent increase in voltage ripple. *Do not allow the core to saturate!* Coiltronics, Coilcraft, Dale and Sumida make high performance inductors in small surface mount packages with low loss ferrite and Kool M μ cores and work well in LTC1474/LTC1475 regulators.

Catch Diode Selection

The catch diode carries load current during the off-time. The average diode current is therefore dependent on the P-channel switch duty cycle. At high input voltages the diode conducts most of the time. As V_{IN} approaches V_{OUT} the diode conducts only a small fraction of the time. The most stressful condition for the diode is when the output is short-circuited. Under this condition, the diode must safely handle I_{PEAK} at close to 100% duty cycle.

To maximize both low and high current efficiency, a fast switching diode with low forward drop and low reverse leakage should be used. Low reverse leakage current is critical to maximize low current efficiency since the leakage can potentially approach the magnitude of the LTC1474/LTC1475 supply current. Low forward drop is critical for high current efficiency since loss is proportional to forward drop. These are conflicting parameters (see Table 1), but a good compromise is the MBR0530 0.5A Schottky diode specified in the application circuits.

Table 1. Effect of Catch Diode on Performance

DIODE (D1)	LEAKAGE	FORWARD DROP	NO LOAD SUPPLY CURRENT	EFFICIENCY*
BAS85	200nA	0.6V	9.7 μ A	77.9%
MBR0530	1 μ A	0.4V	10 μ A	83.3%
MBRS130	20 μ A	0.3V	16 μ A	84.6%

*Figure 1 circuit with V_{IN} = 15V, I_{OUT} = 0.1A

C_{IN} and C_{OUT} Selection

At higher load currents, when the inductor current is continuous, the source current of the P-channel MOSFET is a square wave of duty cycle V_{OUT}/V_{IN}. To prevent large voltage transients, a low ESR input capacitor sized for the maximum RMS current must be used. The maximum capacitor current is given by:

$$C_{IN} \text{ Required } I_{RMS} = \frac{I_{MAX} \left[V_{OUT} (V_{IN} - V_{OUT}) \right]^{1.2}}{V_{IN}}$$

This formula has a maximum at V_{IN} = 2V_{OUT}, where I_{RMS} = I_{OUT}/2. This simple worst-case condition is commonly used for design because even significant deviations do not offer much relief. Note that capacitor manufacturer's ripple current ratings are often based on 2000 hours of life. This makes it advisable to further derate the capacitor, or to choose a capacitor rated at a higher temperature than required. Do not underspecify this component. An additional 0.1 μ F ceramic capacitor is also required on V_{IN} for high frequency decoupling.

The selection of C_{OUT} is driven by the required effective series resistance (ESR) to meet the output voltage ripple and line regulation requirements. The output voltage ripple during a burst cycle is dominated by the output capacitor ESR and can be estimated from the following relation:

$$25\text{mV} < \Delta V_{OUT, RIPPLE} = \Delta I_L \cdot \text{ESR}$$

where $\Delta I_L \leq I_{PEAK}$ and the lower limit of 25mV is due to the voltage comparator hysteresis. Line regulation can also vary with C_{OUT} ESR in applications with a large input voltage range and high peak currents.

ESR is a direct function of the volume of the capacitor. Manufacturers such as Nichicon, AVX and Sprague should

Kool M μ is a registered trademark of Magnetics, Inc.

APPLICATIONS INFORMATION

be considered for high performance capacitors. The OS-CON semiconductor dielectric capacitor available from SANYO has the lowest ESR for its size at a somewhat higher price. Typically, once the ESR requirement is satisfied, the capacitance is adequate for filtering. For lower current applications with peak currents less than 50mA, 10 μ F ceramic capacitors provide adequate filtering and are a good choice due to their small size and almost negligible ESR. AVX and Marcon are good sources for these capacitors.

In surface mount applications multiple capacitors may have to be paralleled to meet the ESR or RMS current handling requirements of the application. Aluminum electrolytic and dry tantalum capacitors are both available in surface mount configurations. In the case of tantalum, it is critical that the capacitors are surge tested for use in switching power supplies. An excellent choice is the AVX TPS series of surface mount tantalums, available in case heights ranging from 2mm to 4mm. Other capacitor types include SANYO OS-CON, Nichicon PL series and Sprague 595D series. Consult the manufacturer for other specific recommendations.

To avoid overheating, the output capacitor must be sized to handle the ripple current generated by the inductor. The worst-case ripple current in the output capacitor is given by:

$$I_{RMS} = I_{PEAK}/2$$

Once the ESR requirement for C_{OUT} has been met, the RMS current rating generally far exceeds the $I_{RIPPLE(P-P)}$ requirement.

Efficiency Considerations

The efficiency of a switching regulator is equal to the output power divided by the input power times 100%. It is often useful to analyze individual losses to determine what is limiting efficiency and which change would produce the most improvement. Efficiency can be expressed as:

$$\text{Efficiency} = 100\% - (L1 + L2 + L3 + \dots)$$

where L1, L2, etc. are the individual losses as a percentage of input power.

Although all dissipative elements in the circuit produce losses, three main sources usually account for most of the losses in LTC1474/LTC1475 circuits: V_{IN} current, I^2R losses and catch diode losses.

1. The V_{IN} current is due to two components: the DC bias current and the internal P-channel switch gate charge current. The DC bias current is 9 μ A at no load and increases proportionally with load up to a constant 100 μ A during continuous mode. This bias current is so small that this loss is negligible at loads above a milliamp but at no load accounts for nearly all of the loss. The second component, the gate charge current, results from switching the gate capacitance of the internal P-channel switch. Each time the gate is switched from high to low to high again, a packet of charge dQ moves from V_{IN} to ground. The resulting dQ/dt is the current out of V_{IN} which is typically much larger than the DC bias current. In continuous mode, $I_{GATECHG} = fQ_P$ where Q_P is the gate charge of the internal switch. Both the DC bias and gate charge losses are proportional to V_{IN} and thus their effects will be more pronounced at higher supply voltages.

2. I^2R losses are predicted from the internal switch, inductor and current sense resistor. At low supply voltages where the switch on-resistance is higher and the switch is on for longer periods due to higher duty cycle, the switch losses will dominate. Keeping the peak currents low with the appropriate R_{SENSE} and with larger inductance helps minimize these switch losses. At higher supply voltages, these losses are proportional to load and result in the flat efficiency curves seen in Figure 1.

3. The catch diode loss is due to the V_{D1D} loss as the diode conducts current during the off-time and is more pronounced at high supply voltage where the on-time is short. This loss is proportional to the forward drop. However, as discussed in the Catch Diode section, diodes with lower forward drops often have higher leakage current, so although efficiency is improved, the no load supply current will increase.

APPLICATIONS INFORMATION

Adjustable Applications

The output voltage is programmed with an external divider from V_{OUT} to V_{FB} (Pin 1) as shown in Figure 4. The regulated voltage is determined by:

$$V_{OUT} = 1.23 \left(1 + \frac{R2}{R1} \right) \quad (4)$$

To minimize no-load supply current, resistor values in the megohm range should be used. The increase in supply current due to the feedback resistors can be calculated from:

$$\Delta I_{VIN} = \left(\frac{V_{OUT}}{R1 + R2} \right) \left(\frac{V_{OUT}}{V_{IN}} \right)$$

A 10pF feedforward capacitor across R2 is necessary due to the high impedances to prevent stray pickup and improve stability.

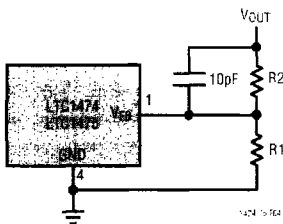

Figure 4. LTC1474/LTC1475 Adjustable Configuration

Low Battery Comparator

The LTC1474/LTC1475 have an on-chip low battery comparator that can be used to sense a low battery condition when implemented as shown in Figure 5. The resistive divider R3/R4 sets the comparator trip point as follows:

$$V_{TRIP} = 1.23 \left(1 + \frac{R4}{R3} \right)$$

The divided down voltage at the LBI pin is compared to the internal 1.23V reference. When $V_{LBI} < 1.23V$, the LBO output sinks current. The low battery comparator is active all the time, even during shutdown mode.

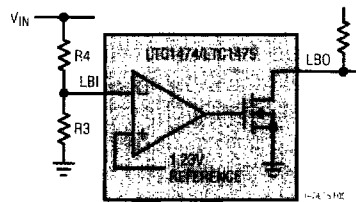

Figure 5. Low Battery Comparator

LTC1475 Pushbutton On/Off and Microprocessor Interface

The LTC1475 provides pushbutton control of power on/off for use with handheld products. A momentary ground on the ON pin sets an internal S/R latch to run mode while a momentary ground on the LBI/OFF pin resets the latch to shutdown mode. See Figure 6 for a comparison of on/off operation of the LTC1474 and LTC1475 and Figure 7 for a comparison of the circuit implementations.

In the LTC1475, the LBI/OFF pin has a dual function as both the shutdown control pin and the low battery comparator input. Since the "OFF" pushbutton is normally open, it does not affect the normal operation of the low battery comparator. In the unpressed state, the LBI/OFF input is the divided down input voltage from the resistive divider to the internal low battery comparator and will normally be above or just below the trip threshold of 1.23V. When shutdown mode is desired, the LBI/OFF pin is pulled below the 0.7V threshold to invoke shutdown.

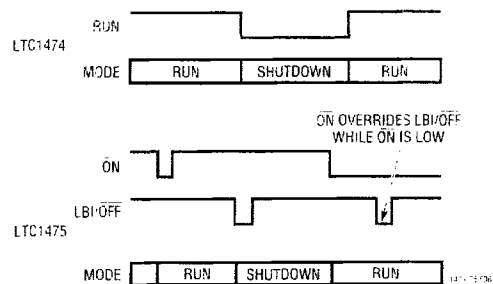

Figure 6. Comparison of LTC1474 and LTC1475 Run/Shutdown Operation

APPLICATIONS INFORMATION

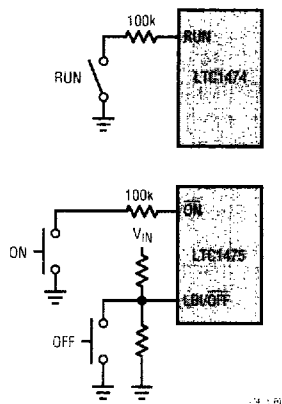

Figure 7. Simplified Implementation of LTC1474 and LTC1475 On/Off

The $\overline{\text{ON}}$ pin has precedence over the $\overline{\text{LBI/OFF}}$ pin. As seen in Figure 6, if both pins are grounded simultaneously, run mode wins.

Figure 17 in the Typical Applications section shows an example for the use of the LTC1475 to control on/off of a microcontroller with a single pushbutton. With both the microcontroller and LTC1475 off, depressing the pushbutton grounds the LTC1475 $\overline{\text{ON}}$ pin and starts up the LTC1475 regulator which then powers up the microcontroller. When the pushbutton is depressed a second time, the depressed switch state is detected by the microcontroller through its input. The microcontroller then pulls the $\overline{\text{LBI/OFF}}$ pin low with the connection to one of its outputs. With the $\overline{\text{LBI/OFF}}$ pin low, the LTC1475 powers down turning the microcontroller off. Note that since the I/O pins of most microcontrollers have a reversed bias diode between input and supply, a blocking diode with less than $1\mu\text{A}$ leakage is necessary to prevent the powered down microcontroller from pulling down on the $\overline{\text{ON}}$ pin.

Figure 18 in the Typical Applications section shows how to use the low battery comparator to provide a low battery lockout on the "ON" switch. The LBO output disconnects the pushbutton from the $\overline{\text{ON}}$ pin when the comparator has tripped, preventing the LTC1475 from attempting to start up again until V_{IN} is increased.

Absolute Maximum Ratings and Latchup Prevention

4

The absolute maximum ratings specify that SW (Pin 5) can never exceed V_{IN} (Pin 7) by more than 0.3V. Normally this situation should never occur. It could, however, if the output is held up while the supply is pulled down. A condition where this could potentially occur is when a battery is supplying power to an LTC1474 or LTC1475 regulator and also to one or more loads in parallel with the regulator's V_{IN} . If the battery is disconnected while the LTC1474 or LTC1475 regulator is supplying a light load and one of the parallel circuits is a heavy load, the input capacitor of the LTC1474 or LTC1475 regulator could be pulled down faster than the output capacitor, causing the absolute maximum ratings to be exceeded. The result is often a latchup which can be destructive if V_{IN} is reapplied. Battery disconnect is possible as a result of mechanical stress, bad battery contacts or use of a lithium-ion battery with a built-in internal disconnect. The user needs to assess his/her application to determine whether this situation could occur. If so, additional protection is necessary.

Prevention against latchup can be accomplished by simply connecting a Schottky diode across the SW and V_{IN} pins as shown in Figure 8. The diode will normally be reverse biased unless V_{IN} is pulled below V_{OUT} at which time the diode will clamp the $(V_{\text{OUT}} - V_{\text{IN}})$ potential to less

APPLICATIONS INFORMATION

than the 0.6V required for latchup. Note that a low leakage Schottky should be used to minimize the effect on no-load supply current. Schottky diodes such as MBR0530, BAS85 and BAT84 work well. Another more serious effect of the protection diode leakage is that at no load with nothing to provide a sink for this leakage current, the output voltage can potentially float above the maximum allowable tolerance. To prevent this from occurring, a resistor must be connected between V_{OUT} and ground with a value low enough to sink the maximum possible leakage current.

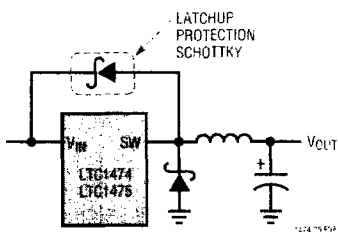

Figure 8. Preventing Absolute Maximum Ratings from Being Exceeded

Thermal Considerations

In the majority of the applications, the LTC1474/LTC1475 do not dissipate much heat due to their high efficiency. However, in applications where the switching regulator is running at high ambient temperature with low supply voltage and high duty cycles, such as dropout with the switch on continuously, the user will need to do some thermal analysis. The goal of the thermal analysis is to determine whether the power dissipated by the regulator exceeds the maximum junction temperature of the part. The temperature rise is given by:

$$T_R = P \cdot \theta_{JA}$$

where P is the power dissipated by the regulator and θ_{JA} is the thermal resistance from the junction of the die to the ambient temperature.

The junction temperature is given by:

$$T_J = T_A + T_R$$

As an example consider the LTC1474/LTC1475 in dropout at an input voltage of 3.5V, a load current of 300mA, and

an ambient temperature of 70°C. From the typical performance graph of switch resistance, the on-resistance of the P-channel switch at 70°C is 3.5Ω. Therefore, power dissipated by the part is:

$$P = I^2 \cdot R_{DS(ON)} = 0.315W$$

For the MSOP package, the θ_{JA} is 150°C/W. Thus the junction temperature of the regulator is:

$$T_J = 70^\circ\text{C} + (0.315)(150) = 117^\circ\text{C}$$

which is near the maximum junction temperature of 125°C. Note that at higher supply voltages, the junction temperature is lower due to reduced switch resistance.

PC Board Layout Checklist

When laying out the printed circuit board, the following checklist should be used to ensure proper operation of the LTC1474/LTC1475. These items are also illustrated graphically in the layout diagram of Figure 9. Check the following in your layout:

1. Is the Schottky diode cathode *closely* connected to SW (Pin 5)?
2. Is the 0.1µF input decoupling capacitor *closely* connected between V_{IN} (Pin 7) and ground (Pin 4)? This capacitor carries the high frequency peak currents.
3. Is the resistive divider closely connected to the (+) and (-) plates of C_{OUT} with a 10pF capacitor connected across R2?
4. Is the 1000pF decoupling capacitor for the current sense resistor connected as close as possible to Pins 6 and 7? If no current sense resistor is used, Pins 6 and 7 should be shorted.
5. Are the signal and power grounds segregated? The signal ground consists of the (-) plate of C_{OUT} , Pin 4 of the LTC1474/LTC1475 and the resistive divider. The power ground consists of the Schottky diode anode, the (-) plate of C_{IN} and the 0.1µF decoupling capacitor.
6. Is a 100k resistor connected in series between RUN (Pin 8) and the RUN control voltage? The resistor should be as close as possible to Pin 8.

APPLICATIONS INFORMATION

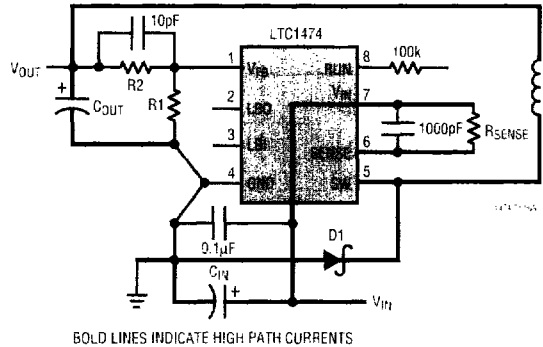

Figure 9. LTC1474/LTC1475 Layout Diagram (See Board Layout Checklist)

Design Example (Refer to R_{SENSE} and Inductor Selection)

As a design example, assume $V_{IN} = 10V$, $V_{OUT} = 3.3V$, and a maximum average output current $I_{MAX} = 100mA$. With this information, we can easily calculate all the important components:

From the equation (1),

$$R_{SENSE} = (0.067/0.1) - 0.25 = 0.42\Omega$$

Using the standard resistors (1Ω , 1Ω and 2Ω) in parallel provides 0.4Ω without having to use a more expensive low value current shunt type resistor (see R_{SENSE} Selection section).

With $R_{SENSE} = 0.4\Omega$, the peak inductor current I_{PEAK} is calculated from (2), neglecting the second term, to be $150mA$. The minimum inductance is, therefore, from the equation (3) and assuming $V_D = 0.4V$,

$$L_{MIN} = \frac{0.75(3.3 + 0.4)(4.75\mu s)}{0.15 - 0.1} = 264\mu H$$

From Figure 3, an inductance of $270\mu H$ is chosen from the recommended region. The CDRH73-271 or CD54-271 is a good choice for space limited applications.

For the feedback resistors, choose $R1 = 1M$ to minimize supply current. $R2$ can then be calculated from the equation (4) to be:

$$R2 = \left(\frac{V_{OUT}}{1.23} - 1 \right) \cdot R1 = 1.68M$$

For the catch diode, the MBR0530 will work well in this application.

For the input and output capacitors, AVX $4.7\mu F$ and $100\mu F$, respectively, low ESR TPS series work well and meet the RMS current requirement of $100mA/2 = 50mA$. They are available in small "C" case sizes with 0.15Ω ESR. The 0.15Ω output capacitor ESR will result in $25mV$ of output voltage ripple.

TYPICAL APPLICATIONS

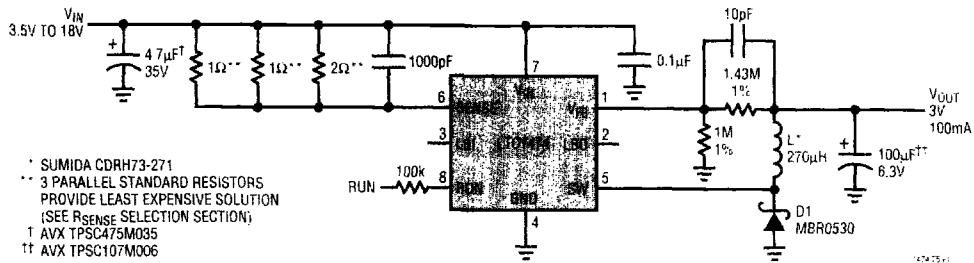

Figure 10. High Efficiency 3V/100mA Regulator

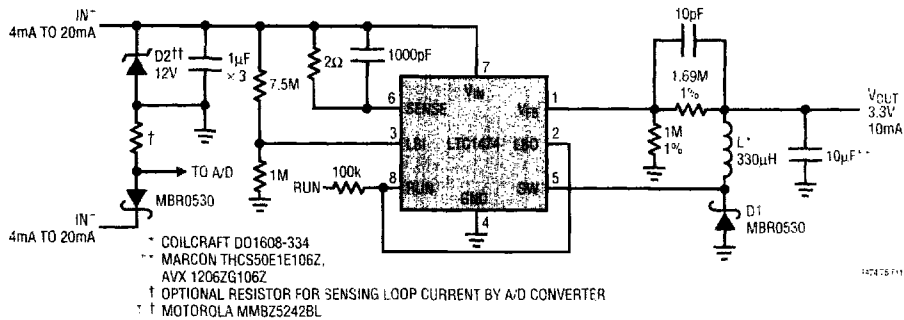

Figure 11. High Efficiency 3.3V/10mA Output from 4mA to 20mA Loop

TYPICAL APPLICATIONS

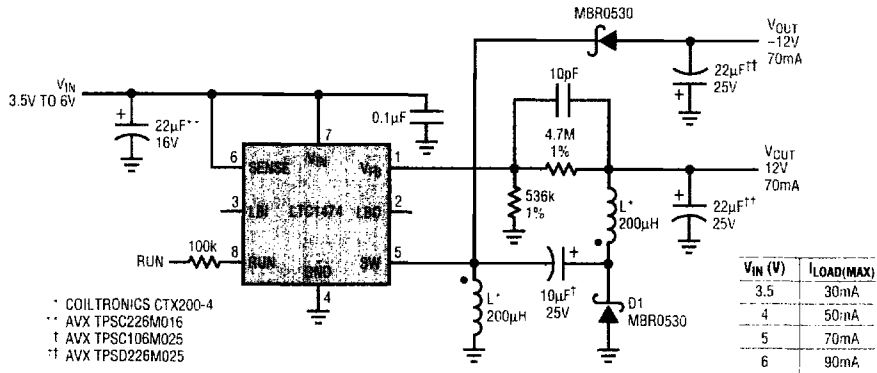

Figure 12. 5V to ±12V Regulator

4

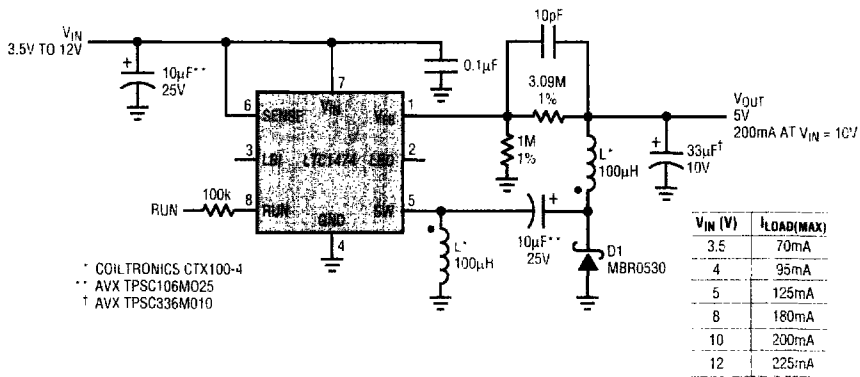

Figure 13. 5V Buck-Boost Converter

TYPICAL APPLICATIONS

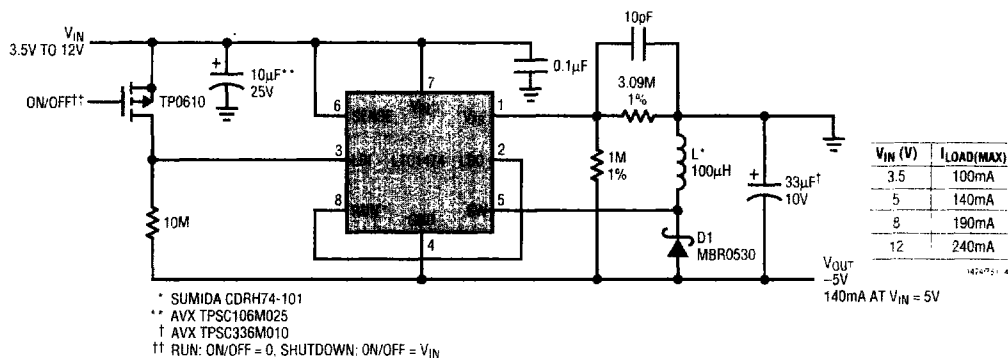

Figure 14. Positive-to-Negative (-5V) Converter

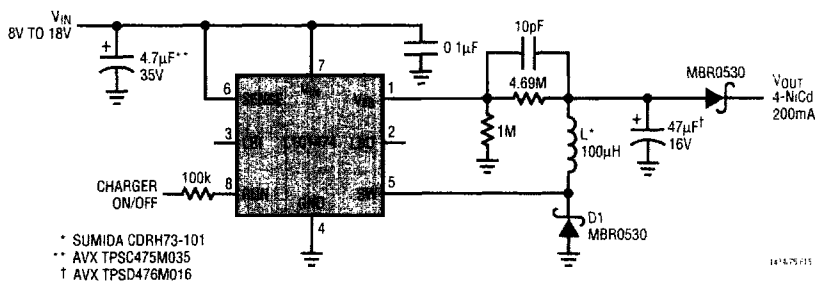

Figure 15. 4-NiCd Battery Charger

TYPICAL APPLICATIONS

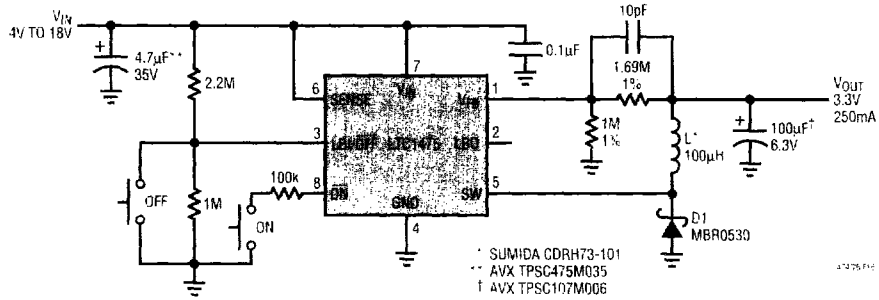

Figure 16. Pushbutton On/Off 3.3V/250mA Regulator

4

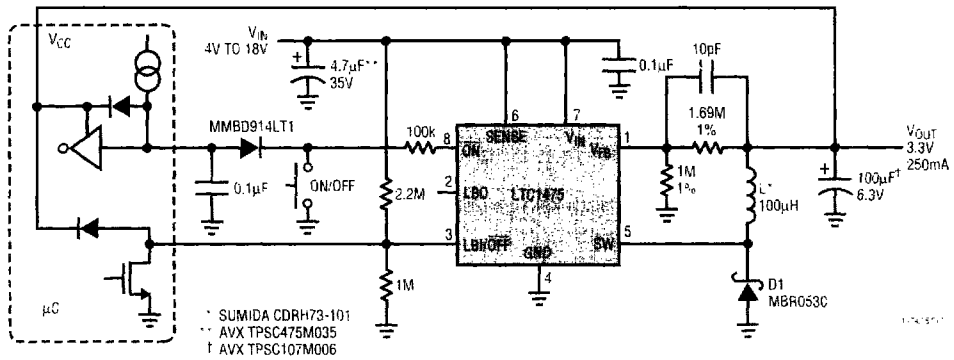

Figure 17. LTC1475 Regulator with 1-Button Toggle On/Off

TYPICAL APPLICATIONS

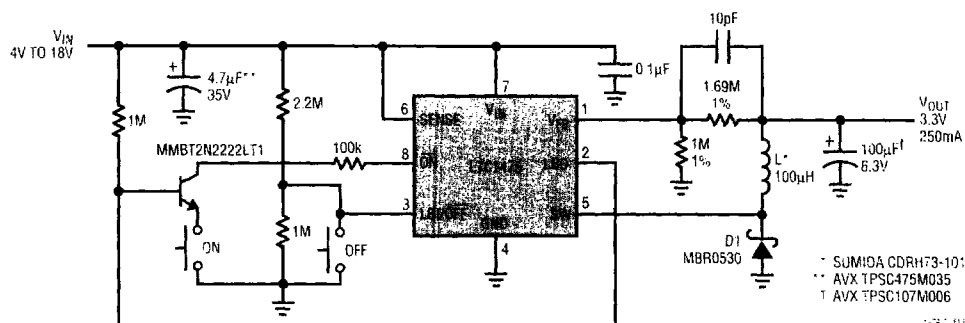

Figure 18. Pushbutton On/Off with Low Battery Lockout

RELATED PARTS

PART NUMBER	DESCRIPTION	COMMENTS
LTC1096/LTC1098	Micropower Sampling 8-Bit Serial I/O A/D Converter	$I_Q = 80\mu\text{A}$ Max
LT1121/LT1121-3.3/LT1121-5	150mA Low Dropout Regulator	Linear Regulator, $I_Q = 30\mu\text{A}$
LTC1174/LTC1174-3.3/LTC1174-5	High Efficiency Step-Down and Inverting DC/DC Converters	Selectable $I_{PEAK} = 300\text{mA}$ or 600mA
LTC1265	1.2A High Efficiency Step-Down DC/DC Converter	Burst Mode Operation, Internal MOSFET
LT1375/LT1376	1.5A 500kHz Step-Down Switching Regulators	500kHz, Small Inductor. High Efficiency Switchers, 1.5A Switch
LTC1440/LTC1441/LTC1442	Ultralow Power Comparator with Reference	$I_Q = 2.8\mu\text{A}$ Max
LT1495/LT1496	1.5µA Precision Rail-to-Rail Op Amps	$I_Q = 1.5\mu\text{A}$ Max
LT1521/LT1521-3/LT1521-3.3/LT1521-5	300mA Low Dropout Regulator	Linear Regulator, $I_Q = 12\mu\text{A}$
LTC1574/LTC1574-3.3/LTC1574-5	High Efficiency Step-Down DC/DC Converters with Internal Schottky Diode	LTC1174 with Internal Schottky Diode
LT1634-1.25	Micropower Precision Shunt Reference	$I_{Q(MIN)} = 10\mu\text{A}$