

Measurement condition

Ambient temperature: 23 °C
 Input power level: 0 dBm
 Terminating impedances: *
 for input: 200 Ω
 for output: 200 Ω

Characteristics

Remark:

Reference level for the relative attenuation a_{rel} of the TFS810 is the minimum of the pass band attenuation a_{min} . The minimum attenuation in the pass band is defined as the insertion loss a_e . The nominal frequency f_N is fixed at 810 MHz without any tolerance or limit. The values of relative attenuation a_{rel} are guaranteed for the whole operating temperature range. The frequency shift of the filter in the operating temperature range is included in the production tolerance scheme.

D a t a		typ. value	tolerance/limit		
Insertion loss	$a_e = a_{min}$	-	max.	4,0	dB
Nominal frequency	f_N	-		810,0	MHz
Pass band	PB	-	f_N	$\pm 8,5$	MHz
Amplitude ripple	within PB	-	max.	1	dB
Relative attenuation	a_{rel}				
801,5 MHz ...	818,5 MHz	-	max.	1,0	dB
660 MHz ...	760 MHz	-	min.	45,0	dB
760 MHz ...	790 MHz	-	min.	15,5	dB
830 MHz ...	860 MHz	-	min.	15,5	dB
860 MHz ...	960 MHz	-	min.	45,0	dB
Group delay	mean value in PB	-	max.	100	ns
Group delay ripple	within PB	-	max.	75	ns
Operating temperature range		-		0 °C ...+ 70	°C
Storage temperature range		-		-40 °C ...+ 80	°C
Temperature coefficient of frequency	TC_f^{**}	T.B.D.			-

*) The terminating impedances depend on parasitics and q-values of matching elements and the board used, and are to be understood as reference values only. Should there be additional questions, do not hesitate to ask for an application note or contact our design team.

***) $\Delta f_C(\text{Hz}) = TC_f(\text{ppm/K}) \times (T - T_A)^2 \times f_{CTA}(\text{MHz})$

generated: _____

checked / approved: _____

TELE FILTER GmbH
Potsdamer Straße 18
D 14 513 TELTOW / Germany
Tel: (+49) 3328 4784-0 / Fax: (+49) 3328 4784-30
E-Mail: tft@telefilter.com

VI TELEFILTER reserves the right to make changes to the product(s) and/or information contained herein without notice. No liability is assumed as a result of their use or application. No rights under any patent accompany the sale of any such product(s) or information.

Construction and pin configuration

(All dimensions in mm)

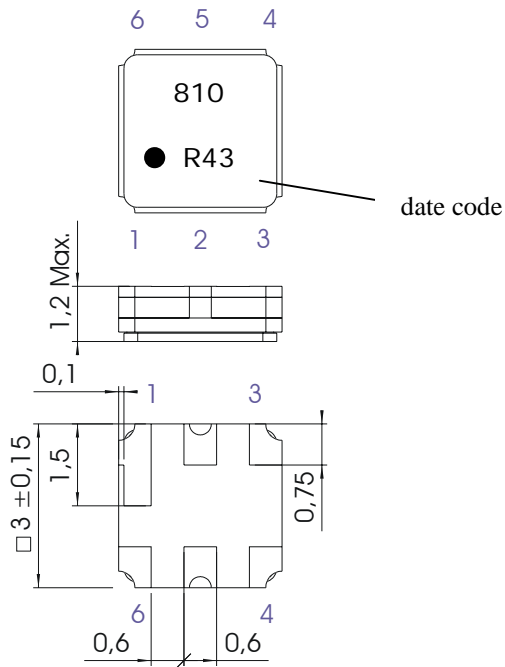

Date code: Year+week

N	2001
P	2002
R	2003
...	

Pin 1	Input
Pin 2	Ground
Pin 3	Output
Pin 4	Output
Pin 5	Ground
Pin 6	Input

TELE FILTER GmbH
Potsdamer Straße 18
D 14 513 TELTOW / Germany
Tel: (+49) 3328 4784-0 / Fax: (+49) 3328 4784-30
E-Mail: tft@telefilter.com

VI TELEFILTER reserves the right to make changes to the product(s) and/or information contained herein without notice. No liability is assumed as a result of their use or application. No rights under any patent accompany the sale of any such product(s) or information.

Stability Characteristics

After the following tests the filter shall meet the whole specification:

1. Shock: 500g, 18 ms, half sine wave, 3 shocks each plane;
DIN IEC 68 T2 - 27
2. Vibration: 10 Hz to 500 Hz, 0,35 mm or 5g respectively, 1 octave per min, 10 cycles per plan, 3 plans;
DIN IEC 68 T2 - 6
3. Change of temperature: -55 °C to 125°C / 30 min. each / 10 cycles
DIN IEC 68 part 2 – 14 Test N
4. Resistance to solder heat (reflow): reflow possible: twice max.;
for temperature conditions, please refer to the attached "Air reflow temperature conditions" on page 4

Packing

Tape & Reel: IEC 286 - 3, with exception of value for N and minimum bending radius;
tape type II, embossed carrier tape with top cover tape on the upper side;

max. pieces of filters per reel: 9000
reel of empty components at start: min 300 mm
reel of empty components at start including leader: min 500 mm
trailer: min 300 mm

Tape (all dimensions in mm)

W	: 8	± 0,3
Po	: 4	± 0,1
Do	: 1,5	+ 0,1
E	: 1,75	± 0,1
F	: 3,5	± 0,05
G (min)	: 0,75	
P2	: 2	± 0,05
P1	: 4	± 0,1
D1(min)	: 1,5	
Ao	: 3,25	± 0,1
Bo	: 3,25	± 0,1
CT	: 5,5	± 0,2

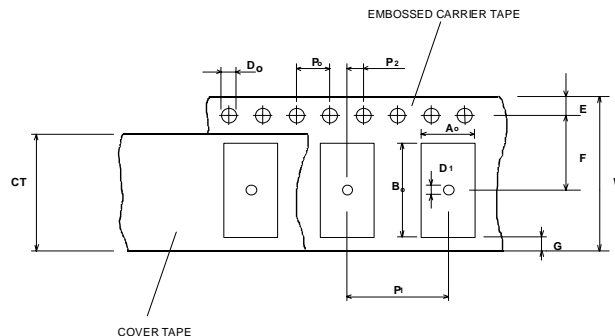
**Reel (all dimensions in mm):**

A	: 330
W1	: 8,4 + 2,0
W2 (max)	: 14,4
N (min)	: 50
C	: 13 +0,5/ -0,2

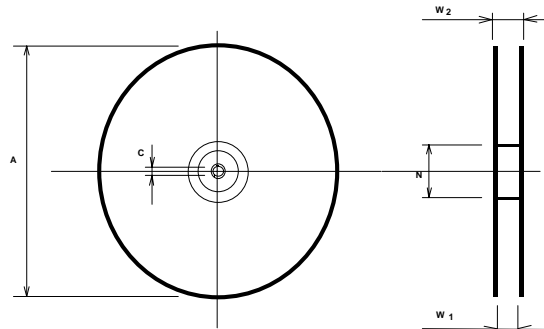

The minimum bending radius is 45 mm. The mounting surface of the filters faces the bottom side of the embossed carrier tape. Markings on the filters can be read if the upper side of the carrier tape is regarded with the sprocket holes on its right.

TELE FILTER GmbH
Potsdamer Straße 18
D 14 513 TELTOW / Germany
Tel: (+49) 3328 4784-0 / Fax: (+49) 3328 4784-30
E-Mail: tft@telefilter.com

VI TELEFILTER reserves the right to make changes to the product(s) and/or information contained herein without notice. No liability is assumed as a result of their use or application. No rights under any patent accompany the sale of any such product(s) or information.

Air reflow temperature conditions

1st and 2nd air reflow profile

Name:	pre-heating periods	main-heating periods	peak temperature
Temperature:	150 °C - 170 °C	over 200 °C	255 °C ± 5 °C
Time:	60 sec. - 90 sec.	20 sec. - 25 sec.	

Chip-mount air reflow profile

Table for temperature vs. time during the air reflow process

Tolerance of temperatures: ± 5 °C

time / sec.	temperature / °C	time / sec.	temperature / °C
0	23	140	160
10	34	150	161
20	46	160	164
30	60	170	170
40	80	180	180
50	103	190	205
60	121	195	230
70	134	200	255
80	143	205	230
90	150	210	205
100	154	215	180
110	156	220	165
120	158	230	140
130	159	240	120

History

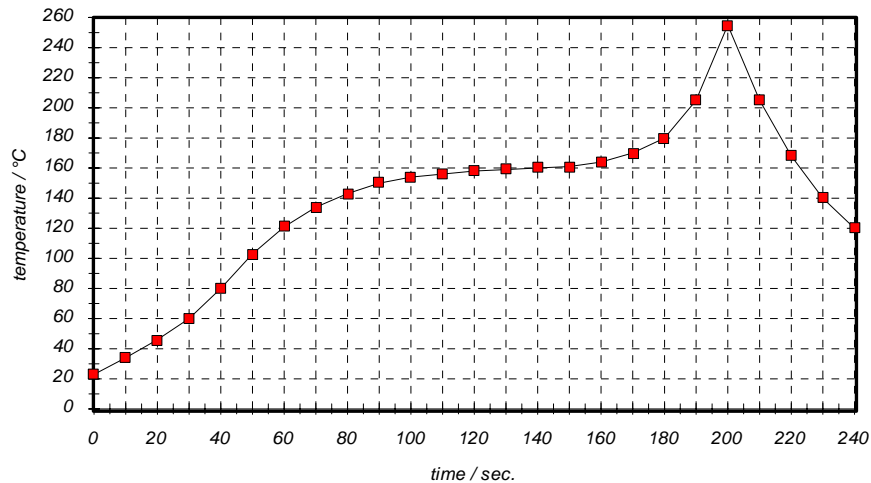
Version	Reason of Changes	Name	Date
1.0	- Generation of development specification	Roizengaft	16.10.2003
1.1	- Change absolute attenuation to relative attenuation	Roizengaft	21.10.2003
1.2	- Add reference for relative attenuation. - Write relative attenuation instead of bandwidth values, - change of package marking	Roizengaft	16.12.2003

TELE FILTER GmbH
Potsdamer Straße 18
D 14 513 TELTOW / Germany
Tel: (+49) 3328 4784-0 / Fax: (+49) 3328 4784-30
E-Mail: tft@telefilter.com

VI TELEFILTER reserves the right to make changes to the product(s) and/or information contained herein without notice. No liability is assumed as a result of their use or application. No rights under any patent accompany the sale of any such product(s) or information.