



MR850 ~ MR856

SOFT RECOVERY, FAST SWITCHING PLASTIC RECTIFIER

VOLTAGE 50 to 600 Volts **CURRENT** 3.0 Amperes

DO-201AD

Unit: inch(mm)

FEATURES

- High current capability.
- Plastic package has Underwriters Laboratory Flammability Classification 94V-O
- Void-free molded plastic package
- Exceeds environmental standards of MIL-S-19500/228
- Fast switching for high efficiency.
- In compliance with EU RoHS 2002/95/EC directives

MECHANICAL DATA

- Case: Molded plastic, DO-201AD
- Terminals: Axial leads, solderable to MIL-STD-750, Method 2026
- Polarity: Color Band denotes cathode end
- Mounting Position: Any
- Weight: 0.0395 ounce, 1.122 gram

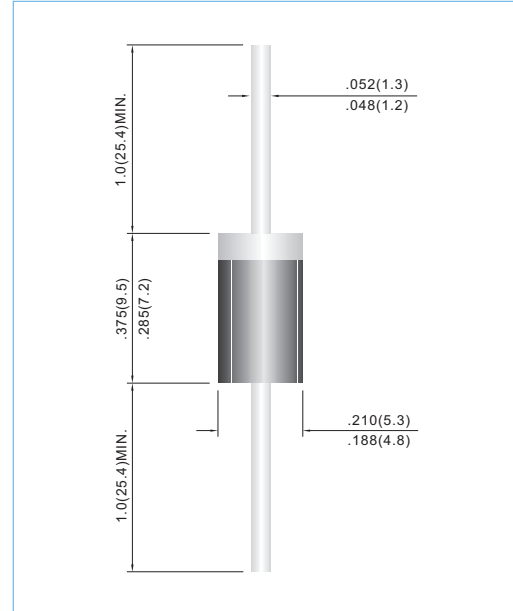

MAXIMUM RATINGS AND ELECTRICAL CHARACTERISTICS

Ratings at 25°C ambient temperature unless otherwise specified. Resistive or inductive load, 60Hz.

PARAMETER	SYMBOL	MR850	MR851	MR852	MR854	MR856	UNITS
Maximum Recurrent Peak Reverse Voltage	V_{RRM}	50	100	200	400	600	V
Maximum RMS Voltage	V_{RMS}	35	70	140	280	420	V
Maximum DC Blocking Voltage	V_{DC}	50	100	200	400	600	V
Maximum Average Forward Current .375" (9.5mm) lead length at $T_A=50^\circ\text{C}$	$I_{F(AV)}$	3.0					A
Peak Forward Surge Current : 10ms single half sine-wave superimposed on rated load(JEDEC method)	I_{FSM}	100					A
Maximum Repetitive Peak Forward Surge (Note 1)	I_{FRM}	10					A
Maximum Forward Voltage at 3.0A	V_F	1.25					V
Maximum DC Reverse Current at $T_J=25^\circ\text{C}$ Rated DC Blocking Voltage $T_J=100^\circ\text{C}$	I_R	10 500					μA
Maximum Reverse Recovery Time (Note 2)	t_{rr}	150					ns
Typical Junction capacitance (Note 3)	C_J	60					pF
Typical Thermal Resistance(Note 4)	$R_{\theta JA}$	15					$^\circ\text{C} / \text{W}$
Operating Junction and Storage Temperature Range	T_J, T_{STG}	-55 to +150					$^\circ\text{C}$

- NOTES: 1. Repetitive Peak Forward Surge Current at $f < 15\text{KHz}$.
 2. Reverse Recovery Test Conditions: $I_F = .5\text{A}$, $I_R = 1\text{A}$, $I_{rr} = .25\text{A}$.
 3. Measured at 1 MHz and applied reverse voltage of 4.0 VDC.
 4. Thermal resistance from junction to ambient and from junction to lead length 0.375" (9.5mm) P.C.B. mounted.



MR850 ~ MR856

RATING AND CHARACTERISTIC CURVES

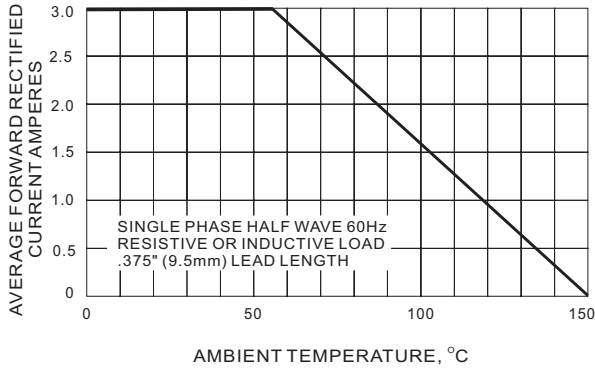

FIG.1 FORWARD CURRENT DERATING CURVE

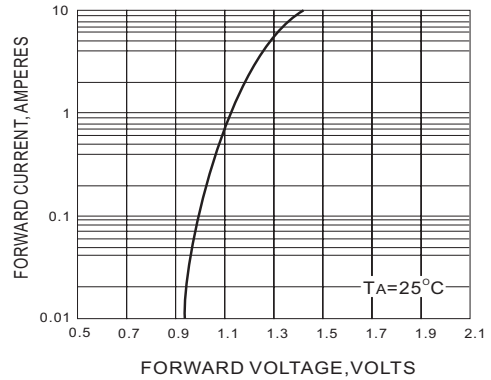

FIG.2 TYPICAL FORWARD CHARACTERISTIC

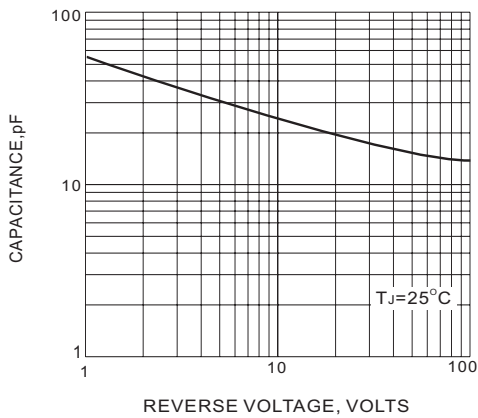

FIG.3 TYPICAL JUNCTION CAPACITANCE

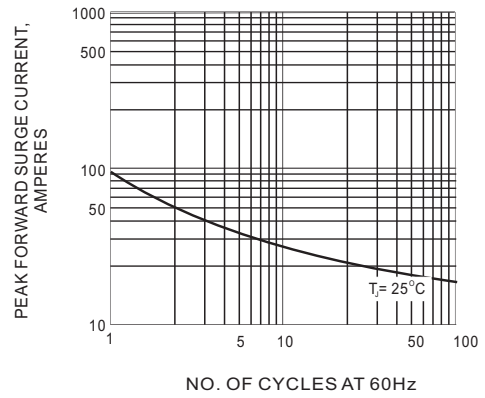

FIG.4 PEAK FORWARD SURGE CURRENT

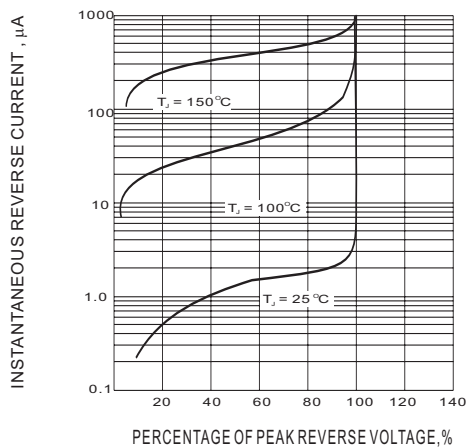

Fig.5-TYPICAL REVERSE CHARACTERISTIC