

SMART REGULATOR[®]s - An Overview

Kieran O'Malley
ON Semiconductor
2000 South County Trail
East Greenwich, RI 02818



ON Semiconductor™

<http://onsemi.com>

APPLICATION NOTE

Introduction

Before the arrival of microprocessors, conventional IC regulators were adequate for most control system applications. Today's more complex systems demand a voltage regulator whose capabilities match those of the components they supply. Like a microprocessor, a regulator must have built-in "smarts" – intelligence, to enhance the microprocessor's and the system's performance. The new breed of SMART REGULATORS now available contain on-chip logic circuitry that provides microprocessor control and supervisory functions. These functions have elevated regulator ICs from their traditional role of simply maintaining a stable supply voltage to important partners in microprocessor control systems.

Background

The main purpose of a linear voltage regulator is to convert a DC input voltage into a lower, stable DC output voltage and to maintain that voltage over a range of line and load conditions.

SMART REGULATORS, linear regulators with one or more control or supervisory functions (Reset, Enable, Watchdog, Wakeup) integrated on chip, offer many benefits in a control system design if the designer considers them to be an integral part of the system. The reset functions eliminate situations where the microprocessor attempts to execute commands when its supply voltage is too low to carry them out correctly. Watchdog monitors the microprocessor's activity, resetting it when its normal software routines are interrupted. Enable and Wakeup conserve power when the microprocessor is not actively engaged in system operations.

Adding these monitor and control functions to a linear regulator IC eliminates the need to implement these functions separately with discrete ICs. Depending on the type of controller system, this can result in a savings of from two to twenty discrete components.

Reducing a system's component count means power dissipation will be lower and reliability will be higher. Moreover, the circuit design will be simpler, easier to debug

and use smaller and less expensive printed circuit boards. These benefits reach through to the manufacturing level where a Smart Regulator reduces production costs by using smaller circuit boards, fewer parts, less insertion and soldering and maintaining a smaller inventory of components.

Basic Regulator Function

All linear regulators operate on the same principle for maintaining a stable output voltage (see Figure 1). The four basic elements are its voltage reference, error amplifier, sense resistor and pass transistor. The bandgap reference, as shown in Figure 1, provides a stable reference voltage that is developed from the highly predictable base-emitter voltage of a NPN transistor. The reference is applied to the non inverting input of the error amplifier. The inverting input receives a sample of the output voltage from a sense resistor in the collector of the pass device. The difference in the two input voltages at the input of the error amplifier produces a voltage at the amplifier's output that controls the bias current of the pass transistor. If the sense resistor voltage rises, the bias current of the pass transistor lessens. Conversely, if the sense resistor voltage falls, the bias current of the pass transistor increases. In Figure 1, the control element is a PNP pass transistor, an increasingly common structure in linear regulators that are specified for low dropout voltages in battery operated systems.

Basic specifications for all linear regulators include its output voltage and tolerance, its output current, line and load regulation, dropout voltage and quiescent current when the IC is in active and sleep mode. Linear regulators also have built in circuitry to protect them during over voltage, short circuit and thermal runaway fault conditions.

For most SMART REGULATORS, the output voltage is 5.0 V since that is the supply voltage used by most TTL and CMOS logic devices, microprocessors and memory chips. Dual-output regulators are available with a 5.0 V output and either an 8.0, 10, or 12 V output to power control elements or other electronics in the system. Regulators having an output voltage of 3.3 V are now appearing to supply new families of 3.0 V microprocessors, memory and logic.

SR001AN/D

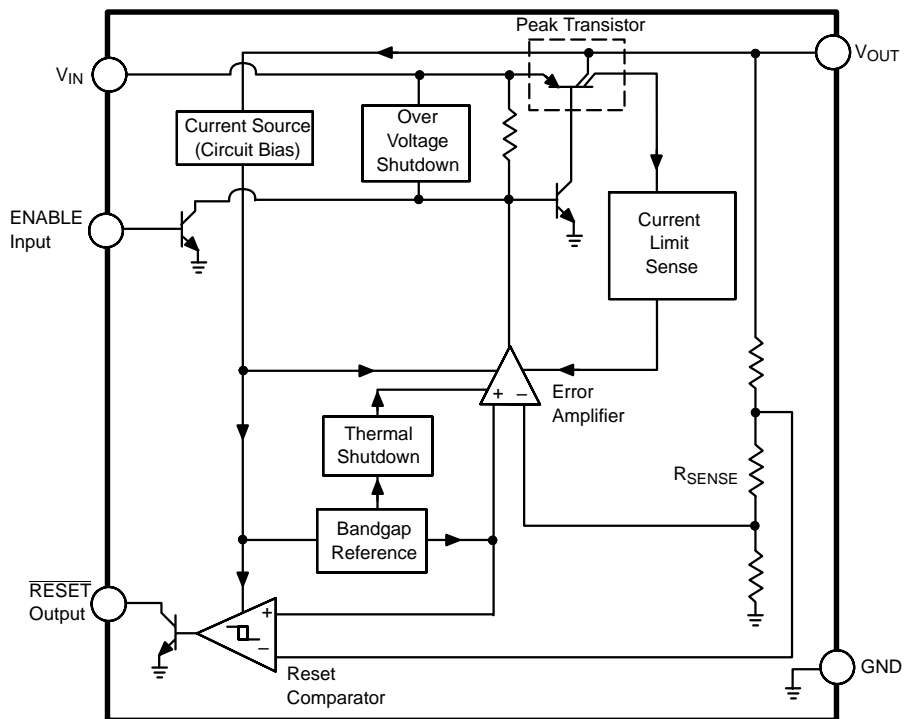

Figure 1. A Linear Voltage Regulator Provides Regulation of Its Output Voltage Through a Feedback Loop that Consists of a Bandgap Reference (as Part of the Voltage Reference), Error Amplifier, Pass Transistor and Sense Resistor (R_{SENSE}) as Shown in this Block Diagram of an ON Semiconductor CS8101 Micropower SMART REGULATOR.

Linear Regulator Terms and Definitions

The tolerance of the output voltage in percentage is the variation from the nominal value of that voltage. A 5.0 V regulator with a $\pm 2.0\%$ tolerance, for example, can have an output voltage that varies from 4.9 V to 5.1 V.

Line regulation is a measure of the change in output voltage for a change in input voltage. It is expressed either in volts or as a percentage change. It is usually specified for a given output current and over a range of input voltages.

Load regulation is a measure of the change in output voltage for a change in output current delivered to the load. It too can be expressed either in volts or as a percentage change. It is usually specified for a given input voltage and over a range of load currents.

Dropout voltage is an especially key specification when a linear regulator is used in a battery powered application. Dropout voltage is the minimum difference between the device's input and output voltages below which regulation stops; i.e.,

$$V_{do} = V_{IN(min)} - V_{OUT(typ)}$$

A low dropout regulator allows the battery voltage to drop very close to V_{OUT} before the regulator falls out of regulation.

Quiescent current, I_Q , is the current that flows back to ground through the linear regulator. In battery operated

systems, I_Q is minimized to prolong battery life. By adding a Sleep mode state, most of the linear regulator's circuitry can be disabled when not needed, and I_Q can be reduced further.

The pass transistor of the linear regulator affects I_Q . It is either an NPN, a composite PNP-NPN or a PNP device. The NPN output structure directs the majority of its current to the load whereas the composite NPN-PNP and the PNP have more of their bias current directed to ground, increasing the I_Q of the regulator.

Linear Regulator Protection

Linear regulators are equipped with built-in circuitry that protects them against over voltage, over temperature and short circuit conditions. If the input voltage rises above a predetermined value, the regulator's output stage shuts down. Thermal runaway is prevented by monitoring the junction temperature of the output transistor, the main contributor to heat in the semiconductor die. If this temperature rises above the manufacturer's specification (typically 180°C), the output transistor is turned off to prevent further overheating. If the regulator's load is shorted, special current-sense limiting circuitry aboard the regulator either turns off or limits the current through the pass transistor, preventing its irreparable damage.

SR001AN/D

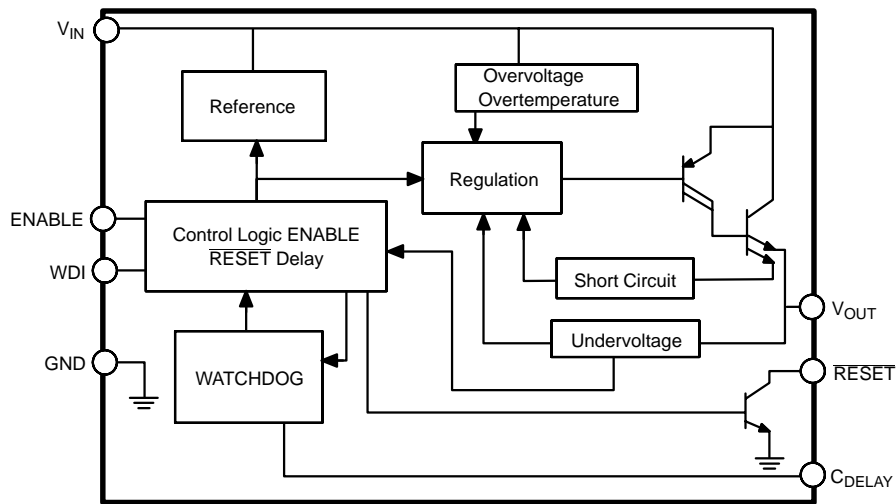

Figure 2. The New Breed of SMART REGULATORS such as the CS8140 Contain Built-In Logic Circuitry to Support and Enhance Microprocessor Operation in a Digital Control System

Packages

IC manufacturers offer a variety of power packages for linear and SMART REGULATORS. They range from inexpensive dual-in-line plastic with fused internal leads to more expensive TO-220 packages with grounded metal tabs and surface mount D²Paks. Proper package selection requires a detailed understanding of the overall system specifications: i.e., $V_{IN(max)}$, $I_{LOAD(max)}$, maximum operating temperature and nominal output voltage, as well as the thermal characteristics of the package and the maximum ambient temperature of the system in which the regulator will operate.

SMART REGULATORS

The new breed of “smart” linear regulators are characterized by their microprocessor-compatible control and supervisory functions. Since all the functions are combined on one IC, control of the microprocessor is more accurate and precise than if the operations were performed using a number of external discrete components.

A SMART REGULATOR that exemplifies this advantage is the CS8140, a single 5.0 V output, low dropout device with on board Watchdog, Reset and Enable (Figure 2). The CS8140 was the first linear regulator IC to incorporate all three of these control functions on chip.

The Watchdog is a system error monitoring function that was previously provided either by a separate discrete microprocessor supervisory chip or by the microprocessor itself. The Watchdog input terminal on the CS8140 (WDI in Figure 2) monitors the input signal sent from the system microprocessor. If the signal from the microprocessor does

not reach the SMART REGULATOR within a certain preset time period, the regulator generates a reset signal to the microprocessor. The reset signal is repeated until a watchdog signal with the correct periodicity occurs. An external capacitor, connected to the regulator’s C_{DELAY} input terminal, programs the watchdog period, as well as the reset and the power-on reset delay time-outs.

The WDI signal is generated by the microprocessor’s software and must appear at the regulator’s WDI port every so many milliseconds. Figure 2 illustrates the timing diagrams for the CS8140 when the WDI falls outside the regulator’s preset period. Initially the WDI signal arrives from the microprocessor as expected. When the WDI fails to arrive within the preset period (Figure 3a) or more than one WDI pulse arrives within that period (Figure 3b), the SMART REGULATOR issues a Reset command to the microprocessor. The Reset pulse continues until the WDI resumes its correct periodicity.

The reset function prevents a microprocessor from executing commands when its supply voltage falls out of specification. A microprocessor can execute commands and generate errors when it’s in an under voltage condition. Reset prevents this by holding the microprocessor inactive until its supply voltage returns to its regulated level. Older reset functions monitored the linear regulator’s input voltage rather than its output voltage. (Under certain conditions, a regulator’s input voltage can disappear while the output voltage remains within specification temporarily, held there by the output capacitor.) The improved reset function in the CS8140 monitors its output voltage and is guaranteed accurate down to $V_{OUT} = 1.0$ V.

SR001AN/D

3a. V_{OUT} when WATCHDOG is too Slow and ENABLE = HIGH

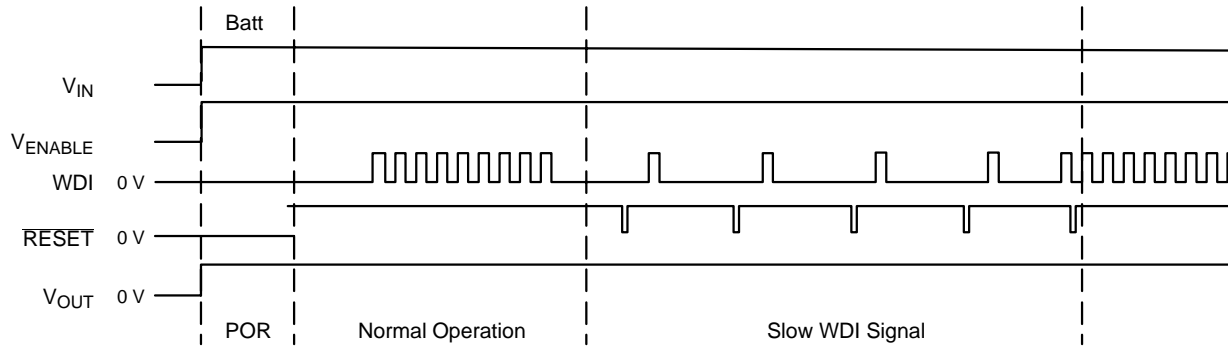

3b. V_{OUT} when WATCHDOG is too Fast and ENABLE = HIGH

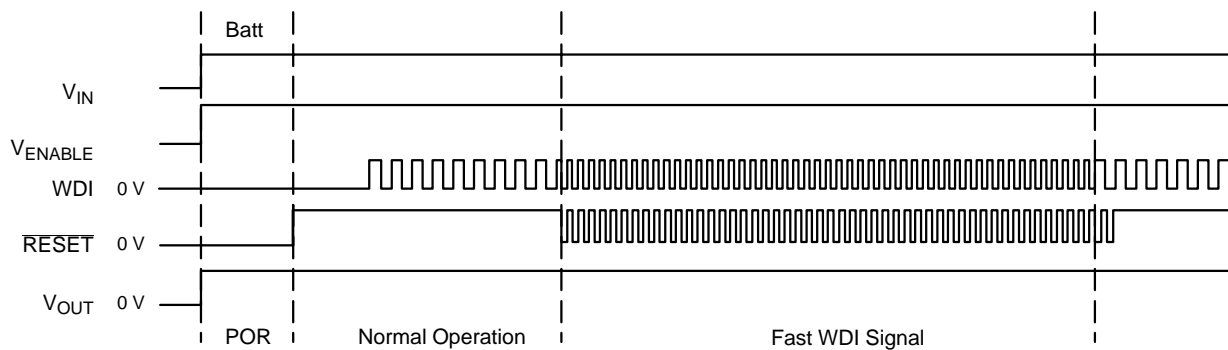

Figure 3. A Watchdog (WDI) Signal Sent From a Microprocessor to a CS8140 SMART REGULATOR Allows the Regulator to Monitor Microprocessor Operation and Prevent Misexecution of Instructions if the Watchdog Signal Ceases or Comes in at the Wrong Frequency

In the CS8140, the on board Enable and Watchdog work together to allow the microprocessor to control its own power-down sequence. As long as the WDI inputs arrive with the proper periodicity (Normal Operation), the enable logic state has no effect (Figure 4). When Enable goes low and WDI ceases, the regulator moves into sleep mode and minimizes energy drain until Enable is pulled high again. In

sleep mode, only the enable circuitry on the regulator retains power and the quiescent current drops dramatically—to only 250 μA in the case of the CS8140. When Enable goes high again, the regulator's output powers up and a power on reset signal is issued to reset the microprocessor. Normal system operation ensues and continues as long as the WDI arrives with the correct periodicity.

WDI held low after a normal period of operation; ENABLE = LOW

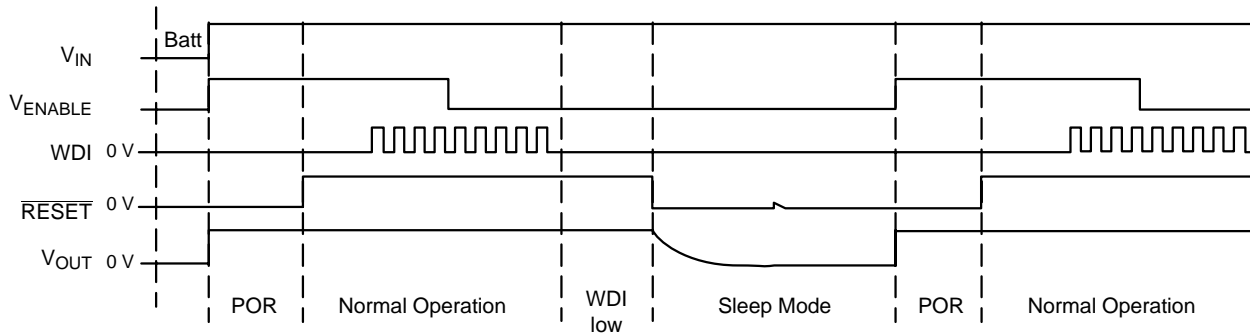

Figure 4. The WDI Can be Used by the Microprocessor to Control its Own Power Down Sequence

The CS8140 illustrates the unique and flexible system control that is possible when microprocessor compatible functions are integrated with the linear regulator. This system is used in critical safety systems where microprocessor misexecutions cannot be tolerated and software housekeeping routines must be attended to prior to microprocessor power down.

A SMART REGULATOR with similar features is the CS8151. In addition to Reset, it contains Watchdog and Wakeup (Figure 5a). The CS8151 has an on-chip Wakeup oscillator that generates a continuous pulse stream (WAKE UP) which is fed to the microprocessor. If the

microprocessor receives a wakeup signal while in sleep mode, it must return a watchdog signal (WDI) to the regulator and check its inputs to determine whether to remain in sleep mode or resume normal operations. Should the regulator receive an incorrect return pulse, it issues a reset signal to the microprocessor (Figure 5b). These functions allow a microprocessor to remain in a low-power sleep mode until there is a need for it to wake up and activate additional circuitry. This type of system control is useful in battery operated security systems where energy drain must be minimized until intrusions occur and alarms and lights must be activated.

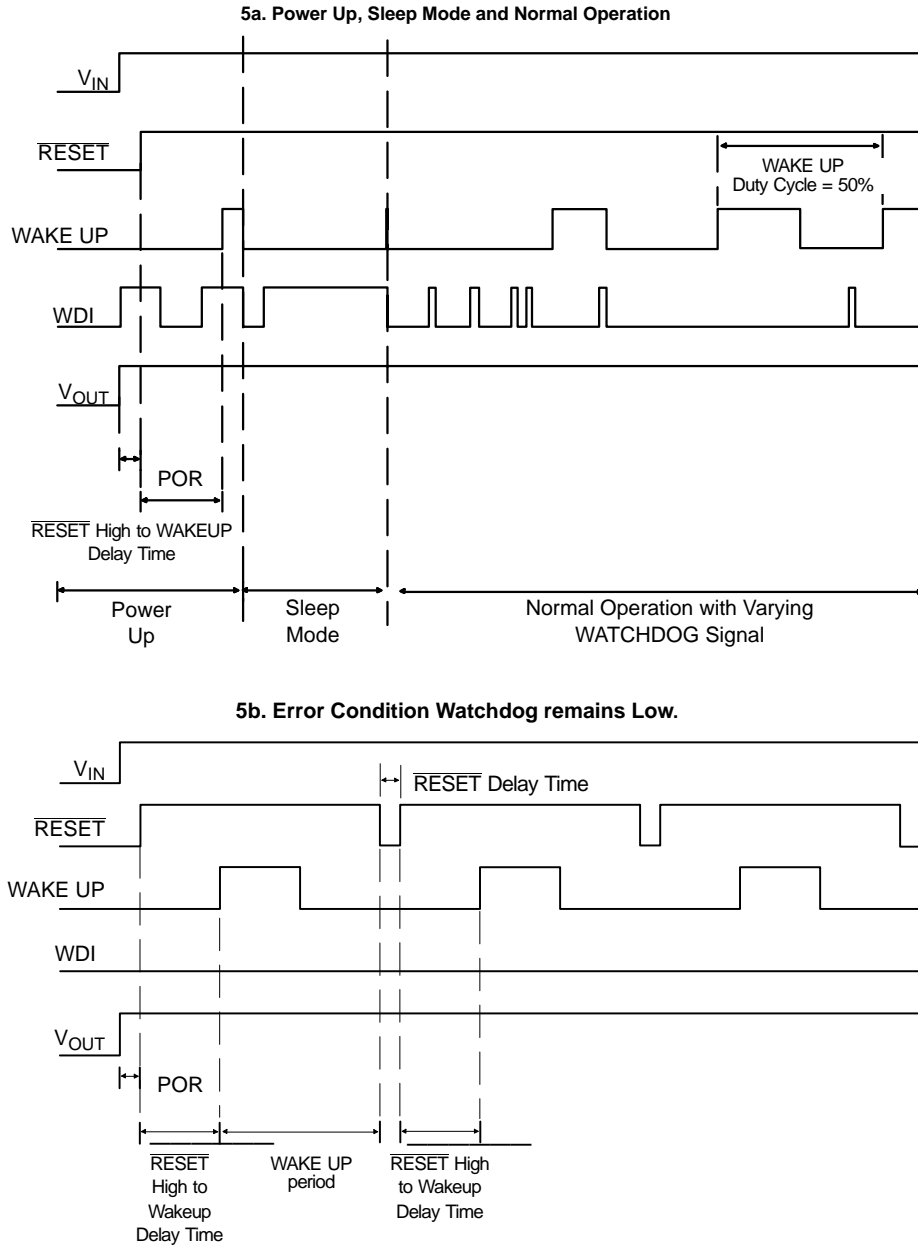

Figure 5. WDI and Wakeup Work Together in the CS8151 to Rouse the Microprocessor from its Sleep State as Needed

SR001AN/D

Summary

With the advent of microprocessor controlled systems, the need has arisen for “value added” regulators that monitor microprocessor behavior and assist in energy conservation. The new family of SMART REGULATORS from ON

Semiconductor fills this niche. On board reset functions protect the system from micropower misexecutions during low voltage conditions. Watchdog monitors the microprocessor activity and Wakeup and Enable conserve power when the microprocessor is inactive.

Notes

SMART REGULATOR is a registered trademark of Semiconductor Components Industries, LLC (SCILLC).

ON Semiconductor and  are trademarks of Semiconductor Components Industries, LLC (SCILLC). SCILLC reserves the right to make changes without further notice to any products herein. SCILLC makes no warranty, representation or guarantee regarding the suitability of its products for any particular purpose, nor does SCILLC assume any liability arising out of the application or use of any product or circuit, and specifically disclaims any and all liability, including without limitation special, consequential or incidental damages. "Typical" parameters which may be provided in SCILLC data sheets and/or specifications can and do vary in different applications and actual performance may vary over time. All operating parameters, including "Typicals" must be validated for each customer application by customer's technical experts. SCILLC does not convey any license under its patent rights nor the rights of others. SCILLC products are not designed, intended, or authorized for use as components in systems intended for surgical implant into the body, or other applications intended to support or sustain life, or for any other application in which the failure of the SCILLC product could create a situation where personal injury or death may occur. Should Buyer purchase or use SCILLC products for any such unintended or unauthorized application, Buyer shall indemnify and hold SCILLC and its officers, employees, subsidiaries, affiliates, and distributors harmless against all claims, costs, damages, and expenses, and reasonable attorney fees arising out of, directly or indirectly, any claim of personal injury or death associated with such unintended or unauthorized use, even if such claim alleges that SCILLC was negligent regarding the design or manufacture of the part. SCILLC is an Equal Opportunity/Affirmative Action Employer.

PUBLICATION ORDERING INFORMATION

Literature Fulfillment:

Literature Distribution Center for ON Semiconductor
P.O. Box 5163, Denver, Colorado 80217 USA
Phone: 303-675-2175 or 800-344-3860 Toll Free USA/Canada
Fax: 303-675-2176 or 800-344-3867 Toll Free USA/Canada
Email: ONlit@hibbertco.com

N. American Technical Support: 800-282-9855 Toll Free USA/Canada

JAPAN: ON Semiconductor, Japan Customer Focus Center
4-32-1 Nishi-Gotanda, Shinagawa-ku, Tokyo, Japan 141-0031
Phone: 81-3-5740-2700
Email: r14525@onsemi.com

ON Semiconductor Website: <http://onsemi.com>

For additional information, please contact your local Sales Representative.