

VI TELEFILTER**Filter specification****TFS 125 H****1/5****Measurement Condition**

Ambient temperature:	23 °C
Input power level:	0 dBm
Source impedance:	50 Ω single ended
Load impedance:	50 Ω single ended
Terminating impedances: *)	input: 1,03 kΩ // -15,4 pF
	output: 0,88 kΩ // -14,8 pF

Characteristics

Remark: Reference level for the relative attenuation a_{rel} of the **TFS 125H** is the minimum of the pass band attenuation. Reference for the echo response attenuation is the main time response lobe, the reference time is defined as t_0 . The nominal frequency f_N is fixed at 125 MHz without tolerance. The given values for the relative attenuation a_{rel} and for the group delay ripple have to be reached at the frequencies given below even if the centre frequency f_C is shifted due to the temperature coefficient of frequency TC_f in the operating temperature range and due to a production tolerance for the centre frequency f_C .

D a t a	typ. Value	Limit
Absolute attenuation within PB	8 dB	7... 10 dB
Nominal frequency f_N	-	125 MHz
Pass band (PB)	-	$f_N \pm 0,6$ MHz
1 dB bandwidth	1,6 MHz	min. 1,2 MHz
Relative attenuation a_{rel}		
f_N ... $f_N \pm 0,1$ MHz	-	max. 0,4 dB
$f_N \pm 0,1$ MHz ... $f_N \pm 0,4$ MHz	-	max. 0,7 dB
$f_N \pm 0,4$ MHz ... $f_N \pm 0,6$ MHz	-	max. 1,85 dB
$f_N \pm 1,2$ MHz ... $f_N \pm 1,8$ MHz	7 dB	min. 6 dB
$f_N \pm 1,8$ MHz ... $f_N \pm 6$ MHz	22 dB	min. 15 dB
$f_N \pm 6$ MHz ... $f_N \pm 13$ MHz	45 dB	min. 40 dB
$f_N - 13$ MHz ... $f_N - 115$ MHz	65 dB	min. 50 dB
$f_N + 13$ MHz ... $f_N + 325$ MHz	70 dB	min. 50 dB
Echo response attenuation a_{rel}		
$t_0 + 2$ μs	37 dB	min. 30 dB
$t_0 + 3$ μs	46 dB	min. 40 dB
$t_0 + 4$ μs	56 dB	min. 50 dB
$t_0 + 5$ μs	65 dB	min. 55 dB
$t_0 + 6$ μs	78 dB	min. 60 dB
Group delay at f_N	700 ns	max. 800 ns
Group delay ripple within PB	50 ns	max. 150 ns
Input power level	-	max. + 10 dBm
VSWR within PB	14 dB	min. 2 : 1
Intermodulation products **	70 dBm	min. 60 dBm
Operating temperature range	-	- 10 °C ... + 85 °C
Storage temperature range	-	- 40 °C ... + 125 °C
Temperature coefficient of frequency	TC_f ***	-0,04 ppm/K ²
Frequency inversion temperature	T_0	20 °C

*) The terminating impedances depend on parasitics and q-values of matching elements and the board used, and are to be understood as reference values only. Should there be additional questions, do not hesitate to ask for an application note or contact our design team.

**) $f_{in,1}=125\text{MHz}$; $f_{in,2}=125,1\text{MHz}$; $P_{in}=4\text{dBm}+\text{loss}$ at f_N ; $f_{out,1}=124,9\text{MHz}$; $f_{out,2}=125,2\text{MHz}$; then $P_{out}<-56\text{dBm}$

***) $\Delta f(\text{Hz}) = TC_f(\text{ppm/K}^2) \times (T-T_0)^2 \times f_{T0}(\text{MHz})$

generated: _____

checked / approved: _____

TELEFILTER GmbH
Potsdamer Straße 18
D 14 513 TELTOW / Germany
Tel: (+49) 3328 4784-0 / Fax: (+49) 3328 4784-30
e-mail: tft@telefilter.com

VI TELEFILTER reserves the right to make changes to the product(s) and/or information contained herein without notice. No liability is assumed as a result of their use or application. No rights under any patent accompany the sale of any such product(s) or information.

Construction and pin configuration

(all dimensions in mm)

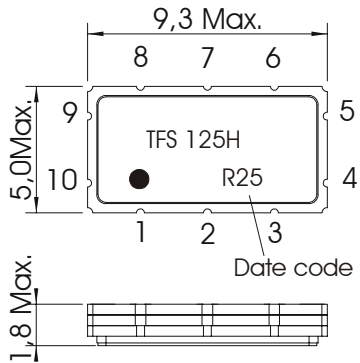

1	ground
2	ground
3	ground
4	output
5	ground
6	ground
7	ground
8	ground
9	ground
10	input

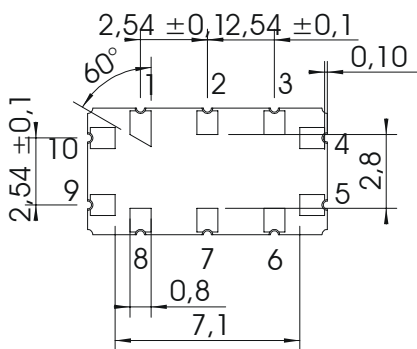

date code:	year + week
N	2001
P	2002
R	2003
....

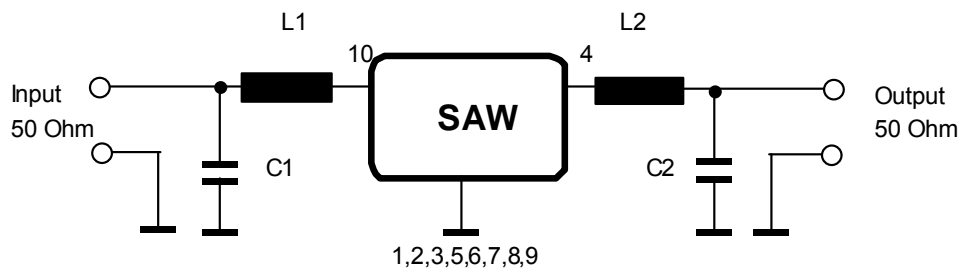
Matching circuit:

TELEFILTER GmbH
 Potsdamer Straße 18
 D 14 513 TELTOW / Germany
 Tel: (+49) 3328 4784-0 / Fax: (+49) 3328 4784-30
 e-mail: tft@telefilter.com

VI TELEFILTER reserves the right to make changes to the product(s) and/or information contained herein without notice. No liability is assumed as a result of their use or application. No rights under any patent accompany the sale of any such product(s) or information.

Stability Characteristics

After the following tests the filter shall meet the whole specification:

1. Shock: 500g, 18 ms, half sine wave, 3 shocks each plane;
DIN IEC 68 T2 - 27
2. Vibration: 10 Hz to 500 Hz, 0,35 mm or 5g respectively, 1 octave per min, 10 cycles per plan, 3 plans;
DIN IEC 68 T2 - 6
3. Change of temperature: -55 °C to 125°C / 30 min. each / 10 cycles
DIN IEC 68 part 2 – 14 Test N
4. Resistance to solder heat (reflow): reflow possible: twice max.;
for temperature conditions refer to the attached "Air reflow temperature conditions" on page 4;

Packing

Tape & Reel: IEC 286 - 3, with exception of value for N and minimum bending radius;
tape type II, embossed carrier tape with top cover tape on the upper side;

max. pieces of filters per reel: 3000
reel of empty components at start: min 300 mm
reel of empty components at start including leader: min 500 mm
trailer: min 300 mm

Tape (all dimensions in mm)

W	: 16 ± 0,3
Po	: 4 ± 0,1
Do	: 1,5 + 0,1
E	: 1,75 ± 0,1
F	: 7,5 ± 0,1
G (min)	: 0,60
P2	: 2 ± 0,1
P1	: 8 ± 0,1
D1(min)	: 1,5
Ao	: 5,30 ± 0,1
Bo	: 9,70 ± 0,1
CT	: 13,5 ± 0,1

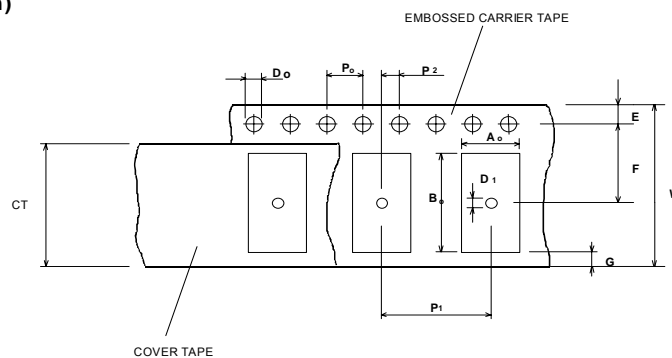
**Reel (all dimensions in mm):**

A	: 330
W1	: 16,4 + 2
W2(max)	: 22,4
N(min)	: 50
C	: 13,0 + 0,5 / - 0,2

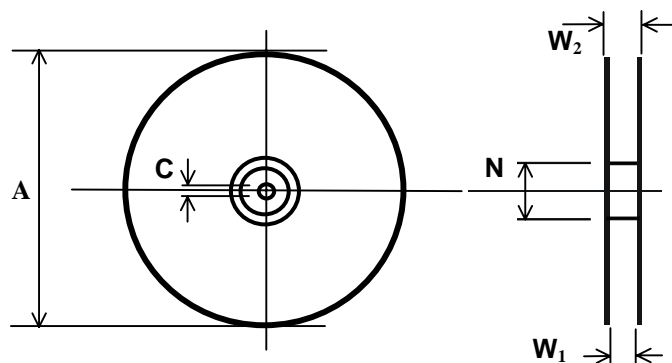

The minimum bending radius is 45 mm. The mounting surface of the filters faces the bottom side of the embossed carrier tape. Markings on the filters can be read if the upper side of the carrier tape is regarded with the sprocket holes on its right.

TELEFILTER GmbH
Potsdamer Straße 18
D 14 513 TELTOW / Germany
Tel: (+49) 3328 4784-0 / Fax: (+49) 3328 4784-30
e-mail: tft@telefilter.com

VI TELEFILTER reserves the right to make changes to the product(s) and/or information contained herein without notice. No liability is assumed as a result of their use or application. No rights under any patent accompany the sale of any such product(s) or information.

Air reflow temperature conditions

1st and 2nd air reflow profile

Name:	pre-heating periods	main-heating periods	peak temperature
Temperature:	150 °C - 170 °C	over 200 °C	255 °C ± 5 °C
Time:	60 sec. - 90 sec.	20 sec. - 25 sec.	

Chip-mount air reflow profile

Table for temperature vs. time during the air reflow process

Tolerance of temperatures: ± 5 °C

time / sec.	temperature / °C	time / sec.	temperature / °C
0	23	140	160
10	34	150	161
20	46	160	164
30	60	170	170
40	80	180	180
50	103	190	205
60	121	195	230
70	134	200	255
80	143	205	230
90	150	210	205
100	154	215	180
110	156	220	165
120	158	230	140
130	159	240	120

History

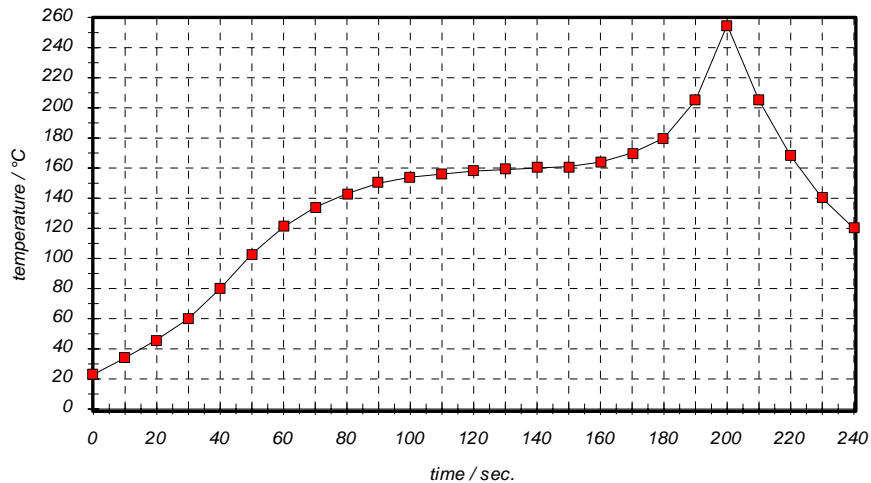
Version	Reason of Changes	Name	Date
Development specification			
1.0	generation of development specification	Pfeiffer	24.01.2003
1.1	typical values and terminating impedance added	Pfeiffer	24.04.2003
1.2	absolute group delay and inband mask changed according customer specification versions 1.0.4 and 2.0.0	Pfeiffer	18.06.2003