

1N3085, 1N3111, 1N5162 SERIES

150 Amp Avg Silicon Rectifier Diodes

Major Ratings and Characteristics

	1N3111	1N3085	1N5162	Units
$I_F(AV)$	150*			A
@ Max. T_C	150*			°C
I_{FSM}	@ 50 Hz	2,850		A
	@ 60 Hz	3,000*		
I^2t	@ 50 Hz	41,000		A ² s
	@ 60 Hz	37,500		
$I^2\sqrt{t}$	580,000			A ² \sqrt{s}
V_{RRM} Range	50	100 - 1000	1200	V

*JEDEC registered value

Description and Features

- Alloy junction for soft recovery characteristics
- Rugged device for duty cycle applications
- Reverse voltage ratings up to 1200 volts
- Applications include power rectification in extreme environmental conditions

CASE STYLE AND DIMENSIONS:

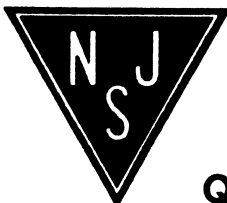
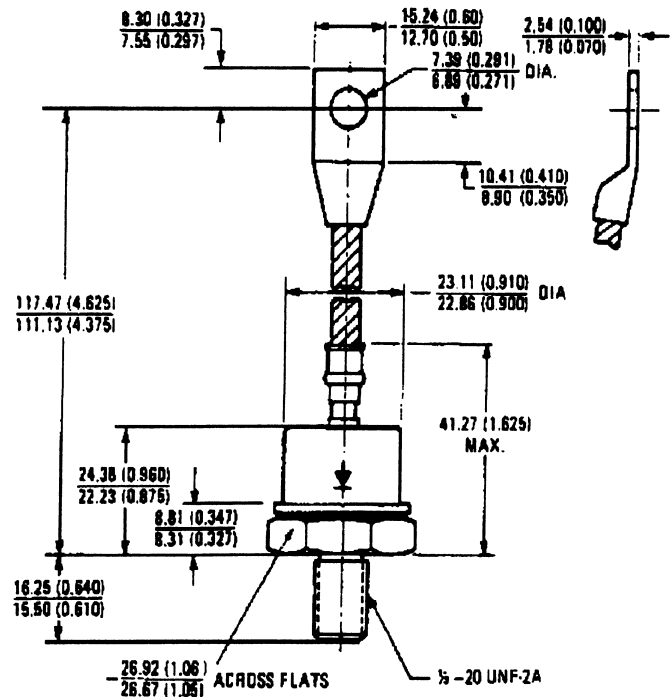

Quality Semi-Conductors

Conforms to JEDEC Outline DO-205AC (DO-30)
 All dimensions in Millimeters and (Inches)

VOLTAGE RATINGS

Part Number ①	V_{RRM} Max. Repetitive Peak Reverse Voltage (V)	V_R Max. Direct Reverse Voltage (V)	$I_{R(AV)}$ Max. Average Reverse Current at Max. Rated $I_{F(AV)}$ and V_{RRM} , $T_C = 150^\circ\text{C}$ 1 Phase Operation (mA)
	$T_C = -65^\circ\text{C to } 200^\circ\text{C}$	$T_C = -65^\circ\text{C to } 200^\circ\text{C}$	
1N3111	50*	40*	25*
1N3085	100*	80*	25*
1N3086	200*	160*	17*
1N3087	300*	240*	17*
1N3088	400*	320*	17*
1N3089	500*	400*	17*
1N3090	600*	480*	17*
1N3091	800*	640*	16*
1N3092	1000*	800*	12*
1N5162	1200*	960*	10*

ELECTRICAL SPECIFICATIONS

		1N3111, 1N3086, 1N5162 Series	Units	Conditions
$I_{F(AV)}$	Max. average forward current	150*	A	180° sinusoidal conduction Max. $T_C = 150^\circ\text{C}$
I_{FSM}	Max. peak one-cycle non-repetitive surge current	2,650	A	Half cycle 50 Hz sine wave or 5 ms rectangular pulse Following any rated load condition and with rated V_{RRM} applied
		3,000*		Half cycle 60 Hz sine wave or 5 ms rectangular pulse
		3,400		Half cycle 50 Hz sine wave or 5 ms rectangular pulse Following any rated load condition and with V_{RRM} applied
		3,550		Half cycle 60 Hz sine wave or 5 ms rectangular pulse applied following surge = 0
I^2t	Max. I^2t for fusing	41,000	A ² s	$t = 10$ ms With rated V_{RRM} applied following surge, initial $T = 200^\circ\text{C}$.
		37,500		$t = 8.3$ ms
	Max. I^2t for individual device fusing	58,000		$t = 10$ ms With $V_{RRM} = 0$ following surge, initial $T = 200^\circ\text{C}$
		53,000		$t = 8.3$ ms
$I^2\sqrt{t}$	Max. $I^2\sqrt{t}$ for individual device fusing ②	580,000	A ² \sqrt{s}	$t = 0.1$ to 10 ms, $V_{RRM} = 0$ following surge.
V_{FM}	Max. peak forward voltage	1.2*	V	$I_{F(AV)} = 150$ A (471 A peak), $T_C = 150^\circ\text{C}$

THERMAL-MECHANICAL SPECIFICATIONS

T_C	Max. operating case temperature range	-65° to 200°	°C	
T_{stg}	Max. storage temperature range	-65° to 200°	°C	
R_{thJC}	Max. internal thermal resistance, junction-to-case	0.25*	deg C/W	DC operation
R_{thCS}	Thermal resistance, case-to-sink	0.10	deg C/W	Mounting surface flat, smooth, and gressed
T	Mounting torque	Min.	14.1 (125)	Nm (lb·in)
		Max.	17.0 (150)	
wt	Approximate weight	91 (3.2)	g (oz)	
	Case style	DO-206AC (DO-30)		JEDEC

① Basic part number indicates cathode-to-case. For anode-to-case, add "R" to part number, e.g. 1N3086R.

*JEDEC registered values.

② I^2t for time $t_x = I^2\sqrt{t} \cdot \sqrt{t_x}$