

CY8C21234, CY8C21334,
CY8C21434, CY8C21534, and CY8C21634

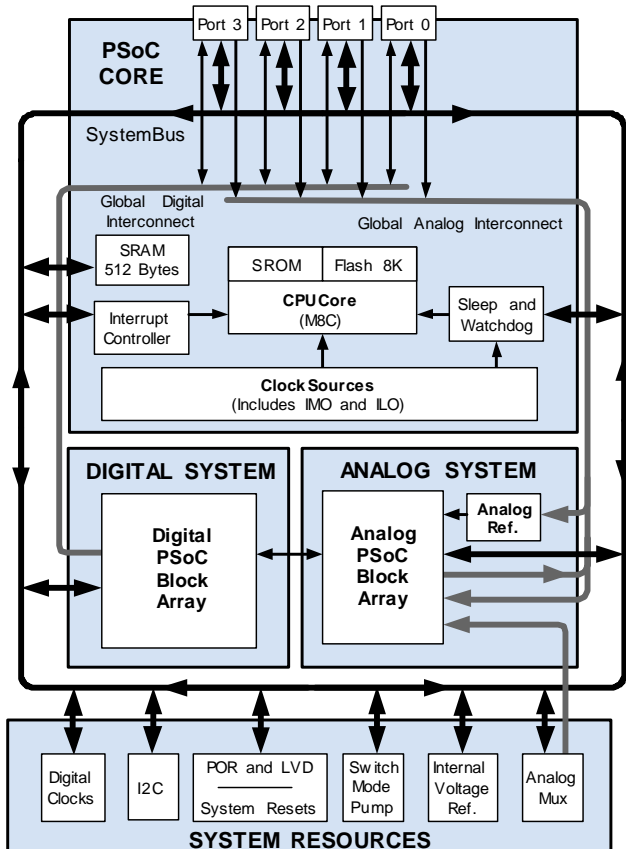

Features

- **Powerful Harvard Architecture Processor**
 - M8C Processor Speeds to 24 MHz
 - Low Power at High Speed
 - 2.4V to 5.25V Operating Voltage
 - Operating Voltages Down to 1.0V Using On-Chip Switch Mode Pump (SMP)
 - Industrial Temperature Range: -40°C to +85°C
- **Advanced Peripherals (PSoC Blocks)**
 - 4 Analog Type "E" PSoC Blocks Provide:
 - 2 Comparators with DAC Refs
 - Two 8-Bit 28 Channel ADCs
 - 4 Digital PSoC Blocks Provide:
 - 8- to 32-Bit Timers, Counters, and PWMs
 - CRC and PRS Modules
 - Full-Duplex UART, SPI™ Master or Slave
 - Connectable to All GPIO Pins
 - Complex Peripherals by Combining Blocks
- **Flexible On-Chip Memory**
 - 8K Flash Program Storage 50,000 Erase/Write Cycles
 - 512 Bytes SRAM Data Storage
 - In-System Serial Programming (ISSP™)
 - Partial Flash Updates
 - Flexible Protection Modes
 - EEPROM Emulation in Flash
- **Complete Development Tools**
 - Free Development Software (PSoC™ Designer)
 - Full-Featured, In-Circuit Emulator and Programmer
 - Full Speed Emulation
 - Complex Breakpoint Structure
 - 128K Bytes Trace Memory
- **Precision, Programmable Clocking**
 - Internal ±2.5% 24/48 MHz Oscillator
 - Internal Oscillator for Watchdog and Sleep
- **Programmable Pin Configurations**
 - 25 mA Drive on All GPIO
 - Pull Up, Pull Down, High Z, Strong, or Open Drain Drive Modes on All GPIO
 - Up to 8 Analog Inputs on GPIO
 - Configurable Interrupt on All GPIO
- **Versatile Analog Mux**
 - Common Internal Analog Bus
 - Simultaneous Connection of IO Combinations
 - Capacitive Sensing Application Capability
- **Additional System Resources**
 - I²C™ Master, Slave and Multi-Master to 400 kHz
 - Watchdog and Sleep Timers
 - User-Configurable Low Voltage Detection
 - Integrated Supervisory Circuit
 - On-Chip Precision Voltage Reference



PSoC™ Functional Overview

The PSoC™ family consists of many *Mixed-Signal Array with On-Chip Controller* devices. These devices are designed to replace multiple traditional MCU-based system components with one, low cost single-chip programmable component. A PSoC device includes configurable blocks of analog and digital logic, as well as programmable interconnect. This architecture allows the user to create customized peripheral configurations, to match the requirements of each individual application. Additionally, a fast CPU, Flash program memory, SRAM data memory, and configurable IO are included in a range of convenient pinouts.

The PSoC architecture, as illustrated on the left, is comprised of four main areas: the Core, the System Resources, the Digital System, and the Analog System. Configurable global bus resources allow all the device resources to be combined into a complete custom system. Each CY8C21x34 PSoC device includes four digital blocks and four analog blocks. Depending on the PSoC package, up to 28 general purpose IO (GPIO) are also included. The GPIO provide access to the global digital and analog interconnects.

The PSoC Core

The PSoC Core is a powerful engine that supports a rich instruction set. It encompasses SRAM for data storage, an interrupt controller, sleep and watchdog timers, and IMO (internal main oscillator) and ILO (internal low speed oscillator). The

CPU core, called the M8C, is a powerful processor with speeds up to 24 MHz. The M8C is a four MIPS 8-bit Harvard architecture microprocessor.

System Resources provide additional capability, such as digital clocks to increase the flexibility of the PSoC mixed-signal arrays, I2C functionality for implementing an I2C master, slave, MultiMaster, an internal voltage reference that provides an absolute value of 1.3V to a number of PSoC subsystems, a switch mode pump (SMP) that generates normal operating voltages off a single battery cell, and various system resets supported by the M8C.

The Digital System is composed of an array of digital PSoC blocks, which can be configured into any number of digital peripherals. The digital blocks can be connected to the GPIO through a series of global buses that can route any signal to any pin. Freeing designs from the constraints of a fixed peripheral controller.

The Analog System is composed of four analog PSoC blocks, supporting comparators and analog-to-digital conversion up to 8 bits in precision.

The Digital System

The Digital System is composed of 4 digital PSoC blocks. Each block is an 8-bit resource that can be used alone or combined with other blocks to form 8, 16, 24, and 32-bit peripherals, which are called user module references. Digital peripheral configurations include those listed below.

- PWMs (8 to 32 bit)
- PWMs with Dead band (8 to 32 bit)
- Counters (8 to 32 bit)
- Timers (8 to 32 bit)
- UART 8 bit with selectable parity
- SPI master and slave
- I2C slave and multi-master
- Cyclical Redundancy Checker/Generator (8 to 32 bit)
- IrDA
- Pseudo Random Sequence Generators (8 to 32 bit)

The digital blocks can be connected to any GPIO through a series of global buses that can route any signal to any pin. The buses also allow for signal multiplexing and for performing logic operations. This configurability frees your designs from the constraints of a fixed peripheral controller.

Digital blocks are provided in rows of four, where the number of blocks varies by PSoC device family. This allows you the optimum choice of system resources for your application. Family resources are shown in the table titled “PSoC Device Characteristics” on page 3.

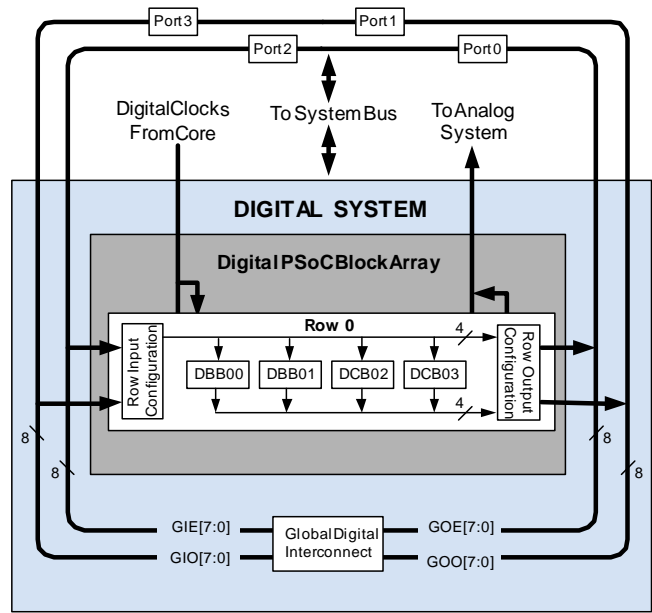

Digital System Block Diagram

The Analog System

The Analog System is composed of 4 configurable blocks, allowing the creation of complex analog signal flows. Analog peripherals are very flexible and can be customized to support specific application requirements. Some of the common PSoC analog functions for this device (most available as user modules) are listed below.

- Analog-to-digital converters (up to 2, with 8-bit resolution)
- Pin-to-pin comparator
- Single-ended comparators (up to 2) with absolute (1.3V) reference or 8-bit DAC reference
- 1.3V reference (as a System Resource)

In most PSoC devices, analog blocks are provided in columns of three, which includes one CT (Continuous Time) and two SC (Switched Capacitor) blocks. The CY8C21x34 devices provide limited functionality Type “E” analog blocks. Each column contains one CT Type E block and one SC Type E block. Refer to the *PSoC Mixed-Signal Array Technical Reference Manual* for detailed information on the CY8C21x34’s Type E analog blocks.

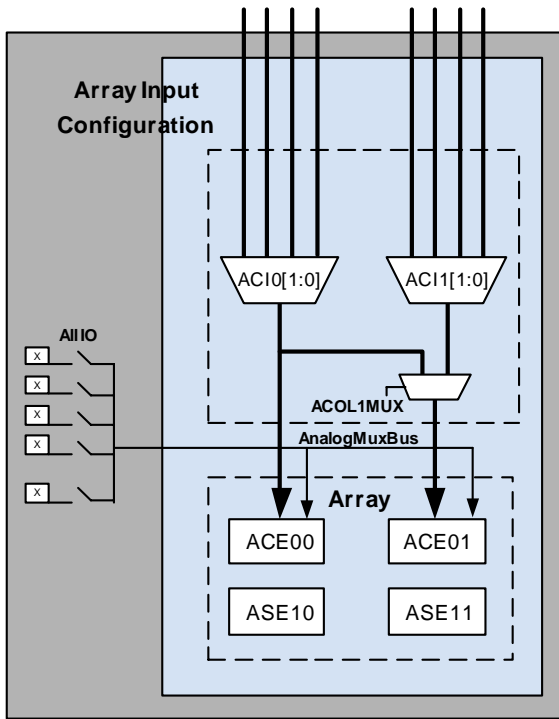

Analog System Block Diagram

The Analog Multiplexer System

The Analog Mux Bus can connect to every GPIO pin. Pins can be connected to the bus individually or in any combination. The bus also connects to the analog system for analysis with comparators and analog-to-digital converters. An additional 8:1 analog input multiplexer provides a second path to bring Port 0 pins to the analog array.

Switch control logic enables selected pins to precharge continuously under hardware control. This enables capacitive measurement for applications such as touch sensing. Other multiplexer applications include:

- Track pad, finger sensing.
- Chip-wide mux that allows analog input from any IO pin.
- Crosspoint connection between any IO pin combinations.

Additional System Resources

System Resources, some of which have been previously listed, provide additional capability useful to complete systems. Additional resources include a switch mode pump, low voltage detection, and power on reset. Brief statements describing the merits of each system resource are presented below.

- Digital clock dividers provide three customizable clock frequencies for use in applications. The clocks can be routed to both the digital and analog systems. Additional clocks can be generated using digital PSoC blocks as clock dividers.
- The I2C module provides 100 and 400 kHz communication over two wires. Slave, master, and multi-master modes are all supported.
- Low Voltage Detection (LVD) interrupts can signal the application of falling voltage levels, while the advanced POR (Power On Reset) circuit eliminates the need for a system supervisor.
- An internal 1.3 voltage reference provides an absolute reference for the analog system, including ADCs and DACs.
- An integrated switch mode pump (SMP) generates normal operating voltages from a single 1.2V battery cell, providing a low cost boost converter.
- Versatile analog multiplexer system.

PSoC Device Characteristics

Depending on your PSoC device characteristics, the digital and analog systems can have 16, 8, or 4 digital blocks and 12, 6, or 4 analog blocks. The following table lists the resources available for specific PSoC device groups. The PSoC device covered by this data sheet is highlighted below.

PSoC Device Characteristics

PSoC Part Number	Digital IO	Digital Rows	Digital Blocks	Analog Inputs	Analog Outputs	Analog Columns	Analog Blocks	SRAM Size	Flash Size
CY8C29x66	up to 64	4	16	12	4	4	12	2K	32K
CY8C24794	up to 56	1	4	48	2	2	6	1K	16K
CY8C27x43	up to 44	2	8	12	4	4	12	256 Bytes	16K
CY8C24x23	up to 24	1	4	12	2	2	6	256 Bytes	4K
CY8C24x23A	up to 24	1	4	12	2	2	6	256 Bytes	4K
CY8C21x34	up to 28	1	4	28	0	2	4^a	512 Bytes	8K
CY8C21x23	16	1	4	8	0	2	4 ^a	256 Bytes	4K

a. Limited analog functionality.

Getting Started

The quickest path to understanding the PSoC silicon is by reading this data sheet and using the PSoC Designer Integrated Development Environment (IDE). This data sheet is an overview of the PSoC integrated circuit and presents specific pin, register, and electrical specifications. For in-depth information, along with detailed programming information, reference the *PSoC™ Mixed-Signal Array Technical Reference Manual*.

For up-to-date Ordering, Packaging, and Electrical Specification information, reference the latest PSoC device data sheets on the web at <http://www.cypress.com/psoc>.

To determine which PSoC device meets your requirements, navigate through the PSoC Decision Tree in the Application Note AN2209 at <http://www.cypress.com/design/results.cfm>.

Development Kits

Development Kits are available from the following distributors: Digi-Key, Avnet, Arrow, and Future. The Cypress Online Store at <http://www.onfulfillment.com/cypressstore/> contains development kits, C compilers, and all accessories for PSoC development. Click on *PSoC (Programmable System-on-Chip)* to view a current list of available items.

Tele-Training

Free PSoC "Tele-Training" is available for beginners and taught by a marketing or application engineer over the phone. Five training classes are available to accelerate the learning curve including introduction, designing, debugging, advanced design, advanced analog, as well as application-specific classes covering topics like PSoC and the LIN bus. For days and times of the tele-training, see <http://www.cypress.com/support/training.cfm>.

Consultants

Certified PSoC Consultants offer everything from technical assistance to completed PSoC designs. To contact or become a PSoC Consultant, go to the following Cypress support web site: <http://www.cypress.com/support/cypros.cfm>.

Technical Support

PSoC application engineers take pride in fast and accurate response. They can be reached with a 4-hour guaranteed response at <http://www.cypress.com/support/login.cfm>.

Application Notes

A long list of application notes will assist you in every aspect of your design effort. To locate the PSoC application notes, go to <http://www.cypress.com/design/results.cfm>.

Development Tools

The Cypress MicroSystems PSoC Designer is a Microsoft® Windows-based, integrated development environment for the Programmable System-on-Chip (PSoC) devices. The PSoC Designer IDE and application runs on Windows NT 4.0, Windows 2000, Windows Millennium (Me), or Windows XP. (Reference the PSoC Designer Functional Flow diagram below.)

PSoC Designer helps the customer to select an operating configuration for the PSoC, write application code that uses the PSoC, and debug the application. This system provides design database management by project, an integrated debugger with In-Circuit Emulator, in-system programming support, and the CYASM macro assembler for the CPUs.

PSoC Designer also supports a high-level C language compiler developed specifically for the devices in the family.

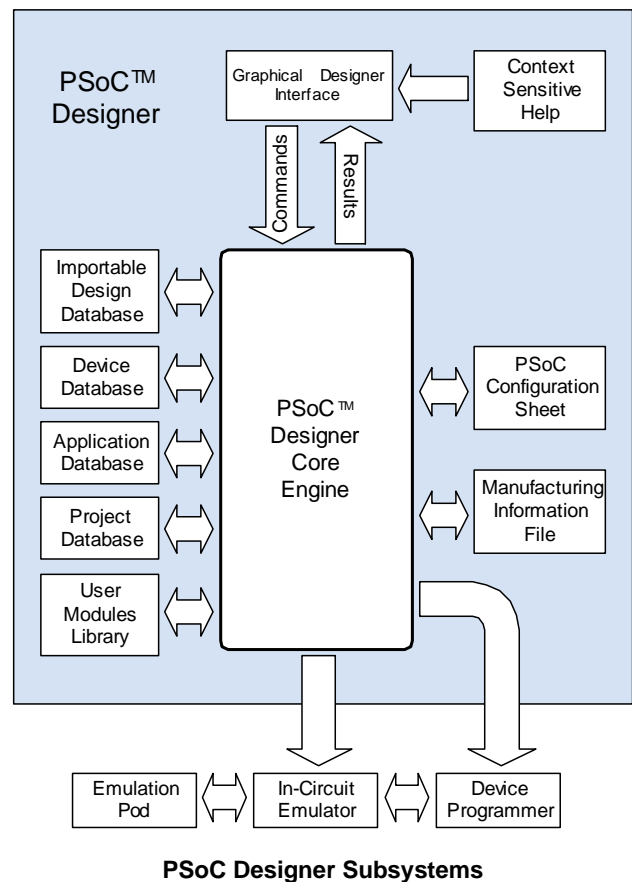

PSoC Designer Software Subsystems

Device Editor

The device editor subsystem allows the user to select different onboard analog and digital components called user modules using the PSoC blocks. Examples of user modules are ADCs, DACs, Amplifiers, and Filters.

The device editor also supports easy development of multiple configurations and dynamic reconfiguration. Dynamic reconfiguration allows for changing configurations at run time.

PSoC Designer sets up power-on initialization tables for selected PSoC block configurations and creates source code for an application framework. The framework contains software to operate the selected components and, if the project uses more than one operating configuration, contains routines to switch between different sets of PSoC block configurations at run time. PSoC Designer can print out a configuration sheet for a given project configuration for use during application programming in conjunction with the Device Data Sheet. Once the framework is generated, the user can add application-specific code to flesh out the framework. It's also possible to change the selected components and regenerate the framework.

Design Browser

The Design Browser allows users to select and import preconfigured designs into the user's project. Users can easily browse a catalog of preconfigured designs to facilitate time-to-design. Examples provided in the tools include a 300-baud modem, LIN Bus master and slave, fan controller, and magnetic card reader.

Application Editor

In the Application Editor you can edit your C language and Assembly language source code. You can also assemble, compile, link, and build.

Assembler. The macro assembler allows the assembly code to be merged seamlessly with C code. The link libraries automatically use absolute addressing or can be compiled in relative mode, and linked with other software modules to get absolute addressing.

C Language Compiler. A C language compiler is available that supports Cypress MicroSystems' PSoC family devices. Even if you have never worked in the C language before, the product quickly allows you to create complete C programs for the PSoC family devices.

The embedded, optimizing C compiler provides all the features of C tailored to the PSoC architecture. It comes complete with embedded libraries providing port and bus operations, standard keypad and display support, and extended math functionality.

Debugger

The PSoC Designer Debugger subsystem provides hardware in-circuit emulation, allowing the designer to test the program in a physical system while providing an internal view of the PSoC device. Debugger commands allow the designer to read the program and read and write data memory, read and write IO registers, read and write CPU registers, set and clear breakpoints, and provide program run, halt, and step control. The debugger also allows the designer to create a trace buffer of registers and memory locations of interest.

Online Help System

The online help system displays online, context-sensitive help for the user. Designed for procedural and quick reference, each functional subsystem has its own context-sensitive help. This system also provides tutorials and links to FAQs and an Online Support Forum to aid the designer in getting started.

Hardware Tools

In-Circuit Emulator

A low cost, high functionality ICE (In-Circuit Emulator) is available for development support. This hardware has the capability to program single devices.

The emulator consists of a base unit that connects to the PC by way of a USB port. The base unit is universal and will operate with all PSoC devices. Emulation pods for each device family are available separately. The emulation pod takes the place of the PSoC device in the target board and performs full speed (24 MHz) operation.

Designing with User Modules

The development process for the PSoC device differs from that of a traditional fixed function microprocessor. The configurable analog and digital hardware blocks give the PSoC architecture a unique flexibility that pays dividends in managing specification change during development and by lowering inventory costs. These configurable resources, called PSoC Blocks, have the ability to implement a wide variety of user-selectable functions. Each block has several registers that determine its function and connectivity to other blocks, multiplexers, buses and to the IO pins. Iterative development cycles permit you to adapt the hardware as well as the software. This substantially lowers the risk of having to select a different part to meet the final design requirements.

To speed the development process, the PSoC Designer Integrated Development Environment (IDE) provides a library of pre-built, pre-tested hardware peripheral functions, called “User Modules.” User modules make selecting and implementing peripheral devices simple, and come in analog, digital, and mixed signal varieties. The standard User Module library contains over 50 common peripherals such as ADCs, DACs Timers, Counters, UARTs, and other not-so common peripherals such as DTMF Generators and Bi-Quad analog filter sections.

Each user module establishes the basic register settings that implement the selected function. It also provides parameters that allow you to tailor its precise configuration to your particular application. For example, a Pulse Width Modulator User Module configures one or more digital PSoC blocks, one for each 8 bits of resolution. The user module parameters permit you to establish the pulse width and duty cycle. User modules also provide tested software to cut your development time. The user module application programming interface (API) provides high-level functions to control and respond to hardware events at run time. The API also provides optional interrupt service routines that you can adapt as needed.

The API functions are documented in user module data sheets that are viewed directly in the PSoC Designer IDE. These data sheets explain the internal operation of the user module and provide performance specifications. Each data sheet describes the use of each user module parameter and documents the setting of each register controlled by the user module.

The development process starts when you open a new project and bring up the Device Editor, a graphical user interface (GUI) for configuring the hardware. You pick the user modules you need for your project and map them onto the PSoC blocks with point-and-click simplicity. Next, you build signal chains by interconnecting user modules to each other and the IO pins. At this stage, you also configure the clock source connections and enter parameter values directly or by selecting values from drop-down menus. When you are ready to test the hardware configuration or move on to developing code for the project, you perform the “Generate Application” step. This causes PSoC Designer to generate source code that automatically configures the device to your specification and provides the high-level user module API functions.

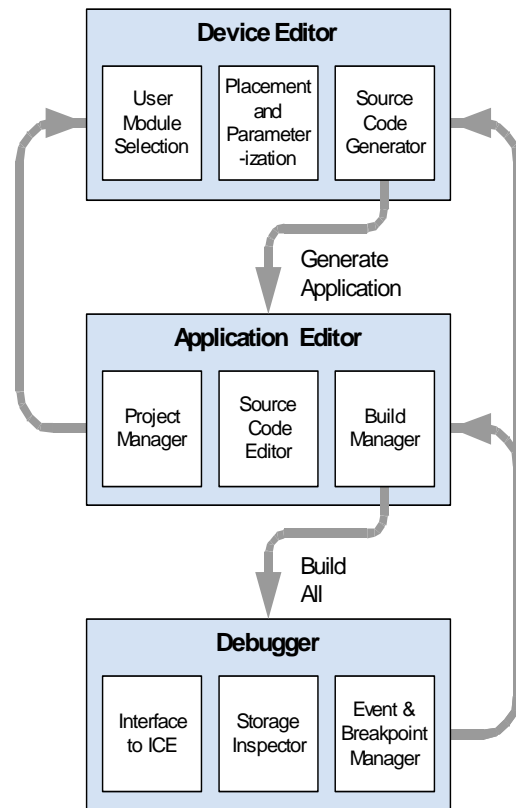

User Module and Source Code Development Flows

The next step is to write your main program, and any sub-routines using PSoC Designer's Application Editor subsystem. The Application Editor includes a Project Manager that allows you to open the project source code files (including all generated code files) from a hierarchical view. The source code editor provides syntax coloring and advanced edit features for both C and assembly language. File search capabilities include simple string searches and recursive “grep-style” patterns. A single mouse click invokes the Build Manager. It employs a professional-strength “makefile” system to automatically analyze all file dependencies and run the compiler and assembler as necessary. Project-level options control optimization strategies used by the compiler and linker. Syntax errors are displayed in a console window. Double clicking the error message takes you directly to the offending line of source code. When all is correct, the linker builds a HEX file image suitable for programming.

The last step in the development process takes place inside the PSoC Designer's Debugger subsystem. The Debugger downloads the HEX image to the In-Circuit Emulator (ICE) where it runs at full speed. Debugger capabilities rival those of systems costing many times more. In addition to traditional single-step, run-to-breakpoint and watch-variable features, the Debugger provides a large trace buffer and allows you define complex breakpoint events that include monitoring address and data bus values, memory locations and external signals.

Document Conventions

Acronyms Used

The following table lists the acronyms that are used in this document.

Acronym	Description
AC	alternating current
ADC	analog-to-digital converter
API	application programming interface
CPU	central processing unit
CT	continuous time
DAC	digital-to-analog converter
DC	direct current
ECO	external crystal oscillator
EEPROM	electrically erasable programmable read-only memory
FSR	full scale range
GPIO	general purpose IO
GUI	graphical user interface
HBM	human body model
ICE	in-circuit emulator
ILO	internal low speed oscillator
IMO	internal main oscillator
IO	input/output
IPOR	imprecise power on reset
LSb	least-significant bit
LVD	low voltage detect
MSb	most-significant bit
PC	program counter
PLL	phase-locked loop
POR	power on reset
PPOR	precision power on reset
PSoC™	Programmable System-on-Chip™
PWM	pulse width modulator
SC	switched capacitor
SLIMO	slow IMO
SMP	switch mode pump
SRAM	static random access memory

Units of Measure

A units of measure table is located in the Electrical Specifications section. [Table 3-1 on page 15](#) lists all the abbreviations used to measure the PSoC devices.

Numeric Naming

Hexidecimal numbers are represented with all letters in uppercase with an appended lowercase 'h' (for example, '14h' or '3Ah'). Hexidecimal numbers may also be represented by a '0x' prefix, the C coding convention. Binary numbers have an appended lowercase 'b' (e.g., '01010100b' or '01000011b'). Numbers not indicated by an 'h', 'b', or 0x are decimal.

Table of Contents

For an in depth discussion and more information on your PSoC device, obtain the *PSoC Mixed-Signal Array Technical Reference Manual* on <http://www.cypress.com>. This document encompasses and is organized into the following chapters and sections.

1. Pin Information	8
1.1 Pinouts	8
1.1.1 16-Pin Part Pinout	8
1.1.2 20-Pin Part Pinout	9
1.1.3 28-Pin Part Pinout	10
1.1.4 32-Pin Part Pinout	11
2. Register Reference	12
2.1 Register Conventions	12
2.2 Register Mapping Tables	12
3. Electrical Specifications	15
3.1 Absolute Maximum Ratings	16
3.2 Operating Temperature	16
3.3 DC Electrical Characteristics	16
3.3.1 DC Chip-Level Specifications	16
3.3.2 DC General Purpose IO Specifications	17
3.3.3 DC Operational Amplifier Specifications	18
3.3.4 DC Switch Mode Pump Specifications	19
3.3.5 DC Analog Mux Bus Specifications	20
3.3.6 DC POR and LVD Specifications	20
3.3.7 DC Programming Specifications	21
3.4 AC Electrical Characteristics	22
3.4.1 AC Chip-Level Specifications	22
3.4.2 AC General Purpose IO Specifications	24
3.4.3 AC Operational Amplifier Specifications	25
3.4.4 AC Analog Mux Bus Specifications	25
3.4.5 AC Digital Block Specifications	25
3.4.6 AC External Clock Specifications	27
3.4.7 AC Programming Specifications	28
3.4.8 AC I2C Specifications	28
4. Packaging Information	30
4.1 Packaging Dimensions	30
4.2 Thermal Impedances	32
4.3 Solder Reflow Peak Temperature	33
5. Ordering Information	34
5.1 Ordering Code Definitions	34
6. Sales and Service Information	35
6.1 Revision History	35
6.2 Copyrights and Code Protection	35

1. Pin Information



This chapter describes, lists, and illustrates the CY8C21x34 PSoC device pins and pinout configurations.

1.1 Pinouts

The CY8C21x34 PSoC device is available in a variety of packages which are listed and illustrated in the following tables. Every port pin (labeled with a "P") is capable of Digital IO and connection to the common analog bus. However, Vss, Vdd, SMP, and XRES are not capable of Digital IO.

1.1.1 16-Pin Part Pinout

Table 1-1. 16-Pin Part Pinout (SOIC)

Pin No.	Type		Name	Description
	Digital	Analog		
1	IO	I, M	P0[7]	Analog column mux input.
2	IO	I, M	P0[5]	Analog column mux input.
3	IO	I, M	P0[3]	Analog column mux input, integrating input.
4	IO	I, M	P0[1]	Analog column mux input, integrating input.
5	Power		SMP	Switch Mode Pump (SMP) connection to required external components.
6	Power		Vss	Ground connection.
7	IO	M	P1[1]	I2C Serial Clock (SCL).
8	Power		Vss	Ground connection.
9	IO	M	P1[0]	I2C Serial Data (SDA).
10	IO	M	P1[2]	
11	IO	M	P1[4]	Optional External Clock Input (EXTCLK).
12	IO	I, M	P0[0]	Analog column mux input.
13	IO	I, M	P0[2]	Analog column mux input.
14	IO	I, M	P0[4]	Analog column mux input.
15	IO	I, M	P0[6]	Analog column mux input.
16	Power		Vdd	Supply voltage.

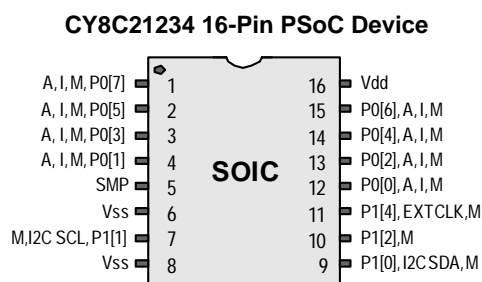

LEGEND A = Analog, I = Input, O = Output, and M = Analog Mux Input.

1.1.2 20-Pin Part Pinout

Table 1-2. 20-Pin Part Pinout (SSOP)

Pin No.	Type		Name	Description
	Digital	Analog		
1	IO	I, M	P0[7]	Analog column mux input.
2	IO	I, M	P0[5]	Analog column mux input.
3	IO	I, M	P0[3]	Analog column mux input, integrating input.
4	IO	I, M	P0[1]	Analog column mux input, integrating input.
5	Power		Vss	Ground connection.
6	IO	M	P1[7]	I2C Serial Clock (SCL).
7	IO	M	P1[5]	I2C Serial Data (SDA).
8	IO	M	P1[3]	
9	IO	M	P1[1]	I2C Serial Clock (SCL).
10	Power		Vss	Ground connection.
11	IO	M	P1[0]	I2C Serial Data (SDA).
12	IO	M	P1[2]	
13	IO	M	P1[4]	Optional External Clock Input (EXT-CLK).
14	IO	M	P1[6]	
15	Input		XRES	Active high external reset with internal pull down.
16	IO	I, M	P0[0]	Analog column mux input.
17	IO	I, M	P0[2]	Analog column mux input.
18	IO	I, M	P0[4]	Analog column mux input.
19	IO	I, M	P0[6]	Analog column mux input.
20	Power		Vdd	Supply voltage.

CY8C21334 20-Pin PSoC Device

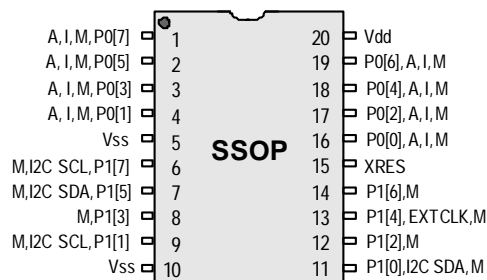

LEGEND A = Analog, I = Input, O = Output, and M = Analog Mux Input.

1.1.3 28-Pin Part Pinout

Table 1-3. 28-Pin Part Pinout (SSOP)

Pin No.	Type		Name	Description
	Digital	Analog		
1	IO	I, M	P0[7]	Analog column mux input.
2	IO	I, M	P0[5]	Analog column mux input and column output.
3	IO	I, M	P0[3]	Analog column mux input and column output, integrating input.
4	IO	I, M	P0[1]	Analog column mux input, integrating input.
5	IO	M	P2[7]	
6	IO	M	P2[5]	
7	IO	I, M	P2[3]	Direct switched capacitor block input.
8	IO	I, M	P2[1]	Direct switched capacitor block input.
9	Power		Vss	Ground connection.
10	IO	M	P1[7]	I2C Serial Clock (SCL).
11	IO	M	P1[5]	I2C Serial Data (SDA).
12	IO	M	P1[3]	
13	IO	M	P1[1]	I2C Serial Clock (SCL).
14	Power		Vss	Ground connection.
15	IO	M	P1[0]	I2C Serial Data (SDA).
16	IO	M	P1[2]	
17	IO	M	P1[4]	Optional External Clock Input (EXT-CLK).
18	IO	M	P1[6]	
19	Input		XRES	Active high external reset with internal pull down.
20	IO	I, M	P2[0]	Direct switched capacitor block input.
21	IO	I, M	P2[2]	Direct switched capacitor block input.
22	IO	M	P2[4]	
23	IO	M	P2[6]	
24	IO	I, M	P0[0]	Analog column mux input.
25	IO	I, M	P0[2]	Analog column mux input.
26	IO	I, M	P0[4]	Analog column mux input.
27	IO	I, M	P0[6]	Analog column mux input.
28	Power		Vdd	Supply voltage.

CY8C21534 28-Pin PSoC Device

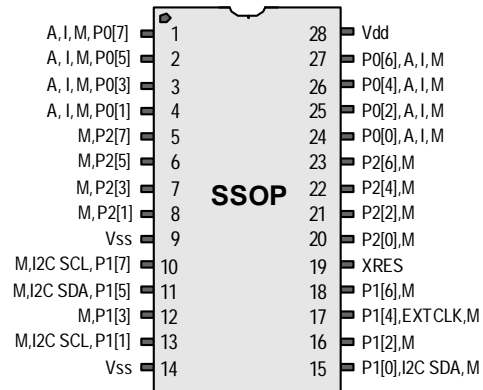

LEGEND A: Analog, I: Input, O = Output, and M = Analog Mux Input.

1.1.4 32-Pin Part Pinout

Table 1-4. 32-Pin Part Pinout (MLF*)

Pin No.	Type		Name	Description
	Digital	Analog		
1	IO	I, M	P0[1]	Analog column mux input, integrating input.
2	IO	M	P2[7]	
3	IO	M	P2[5]	
4	IO	M	P2[3]	
5	IO	M	P2[1]	
6	IO	M	P3[3]	In CY8C21434 part.
6	Power		SMP	Switch Mode Pump (SMP) connection to required external components in CY8C21634 part.
7	IO	M	P3[1]	In CY8C21434 part.
7	Power		Vss	Ground connection in CY8C21634 part.
8	IO	M	P1[7]	I2C Serial Clock (SCL).
9	IO	M	P1[5]	I2C Serial Data (SDA).
10	IO	M	P1[3]	
11	IO	M	P1[1]	I2C Serial Clock (SCL).
12	Power		Vss	Ground connection.
13	IO	M	P1[0]	I2C Serial Data (SDA).
14	IO	M	P1[2]	
15	IO	M	P1[4]	Optional External Clock Input (EXTCLK).
16	IO	M	P1[6]	
17	Input		XRES	Active high external reset with internal pull down.
18	IO	M	P3[0]	
19	IO	M	P3[2]	
20	IO	M	P2[0]	
21	IO	M	P2[2]	
22	IO	M	P2[4]	
23	IO	M	P2[6]	
24	IO	I, M	P0[0]	Analog column mux input.
25	IO	I, M	P0[2]	Analog column mux input.
26	IO	I, M	P0[4]	Analog column mux input.
27	IO	I, M	P0[6]	Analog column mux input.
28	Power		Vdd	Supply voltage.
29	IO	I, M	P0[7]	Analog column mux input.
30	IO	I, M	P0[5]	Analog column mux input.
31	IO	I, M	P0[3]	Analog column mux input, integrating input.
32	Power		Vss	Ground connection.

LEGEND A = Analog, I = Input, O = Output, and M = Analog Mux Input.

* The MLF package has a center pad that must be connected to ground (Vss).

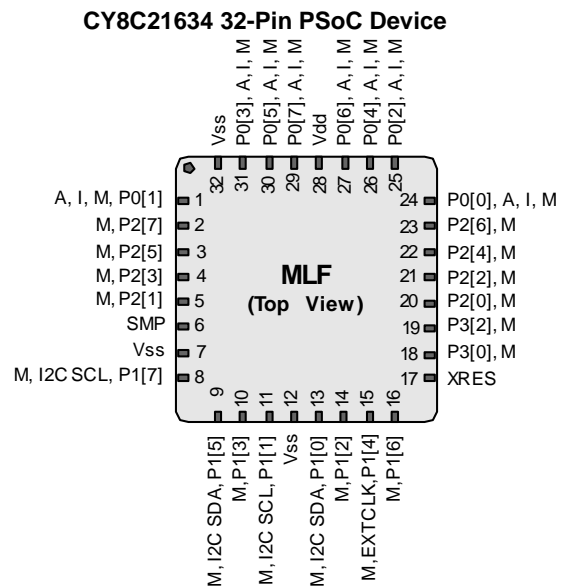
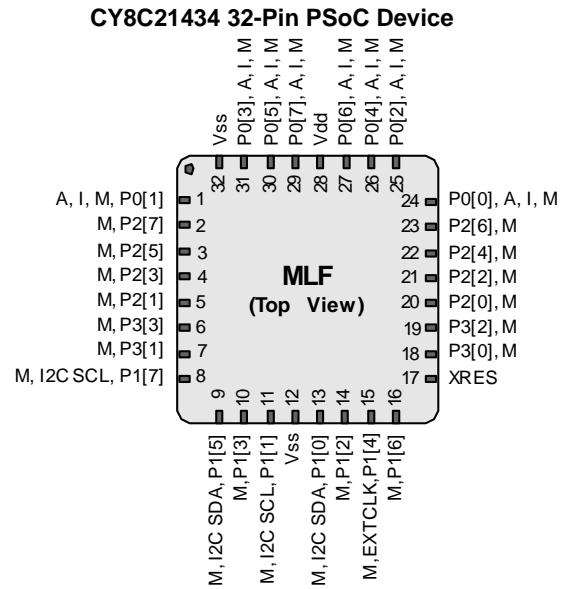

2. Register Reference



This chapter lists the registers of the CY8C21x34 PSoC device. For detailed register information, reference the *PSoC™ Mixed-Signal Array Technical Reference Manual*.

2.1 Register Conventions

The register conventions specific to this section are listed in the following table.

Convention	Description
R	Read register or bit(s)
W	Write register or bit(s)
L	Logical register or bit(s)
C	Clearable register or bit(s)
#	Access is bit specific

2.2 Register Mapping Tables

The PSoC device has a total register address space of 512 bytes. The register space is referred to as IO space and is divided into two banks. The XO1 bit in the Flag register (CPU_F) determines which bank the user is currently in. When the XO1 bit is set the user is in Bank 1.

Note In the following register mapping tables, blank fields are Reserved and should not be accessed.

Register Map 0 Table: User Space

Name	Addr (0,Hex)	Access	Name	Addr (0,Hex)	Access	Name	Addr (0,Hex)	Access	Name	Addr (0,Hex)	Access
PRT0DR	00	RW		40		ASE10CR0	80	RW		C0	
PRT0IE	01	RW		41			81			C1	
PRT0GS	02	RW		42			82			C2	
PRT0DM2	03	RW		43			83			C3	
PRT1DR	04	RW		44		ASE11CR0	84	RW		C4	
PRT1IE	05	RW		45			85			C5	
PRT1GS	06	RW		46			86			C6	
PRT1DM2	07	RW		47			87			C7	
PRT2DR	08	RW		48			88			C8	
PRT2IE	09	RW		49			89			C9	
PRT2GS	0A	RW		4A			8A			CA	
PRT2DM2	0B	RW		4B			8B			CB	
PRT3DR	0C	RW		4C			8C			CC	
PRT3IE	0D	RW		4D			8D			CD	
PRT3GS	0E	RW		4E			8E			CE	
PRT3DM2	0F	RW		4F			8F			CF	
	10			50			90		CUR_PP	D0	RW
	11			51			91		STK_PP	D1	RW
	12			52			92			D2	
	13			53			93		IDX_PP	D3	RW
	14			54			94		MVR_PP	D4	RW
	15			55			95		MVW_PP	D5	RW
	16			56			96		I2C_CFG	D6	RW
	17			57			97		I2C_SCR	D7	#
	18			58			98		I2C_DR	D8	RW
	19			59			99		I2C_MSCR	D9	#
	1A			5A			9A		INT_CLR0	DA	RW
	1B			5B			9B		INT_CLR1	DB	RW
	1C			5C			9C			DC	
	1D			5D			9D		INT_CLR3	DD	RW
	1E			5E			9E		INT_MSK3	DE	RW
	1F			5F			9F			DF	
DBB00DR0	20	#	AMX_IN	60	RW		A0		INT_MSK0	E0	RW
DBB00DR1	21	W	AMUXCFG	61	RW		A1		INT_MSK1	E1	RW
DBB00DR2	22	RW	PWM_CR	62	RW		A2		INT_VC	E2	RC
DBB00CR0	23	#		63			A3		RES_WDT	E3	W
DBB01DR0	24	#	CMP_CR0	64	#		A4			E4	
DBB01DR1	25	W		65			A5			E5	
DBB01DR2	26	RW	CMP_CR1	66	RW		A6		DEC_CR0	E6	RW
DBB01CR0	27	#		67			A7		DEC_CR1	E7	RW
DCB02DR0	28	#	ADC0_CR	68	#		A8			E8	
DCB02DR1	29	W	ADC1_CR	69	#		A9			E9	
DCB02DR2	2A	RW		6A			AA			EA	
DCB02CR0	2B	#		6B			AB			EB	
DCB03DR0	2C	#	TMP0_DR	6C	RW		AC			EC	
DCB03DR1	2D	W	TMP1_DR	6D	RW		AD			ED	
DCB03DR2	2E	RW	TMP2_DR	6E	RW		AE			EE	
DCB03CR0	2F	#	TMP3_DR	6F	RW		AF			EF	
	30			70		RDI0RI	B0	RW		F0	
	31			71		RDI0SYN	B1	RW		F1	
	32		ACE00CR1	72	RW	RDI0IS	B2	RW		F2	
	33		ACE00CR2	73	RW	RDI0LT0	B3	RW		F3	
	34			74		RDI0LT1	B4	RW		F4	
	35			75		RDI0RO0	B5	RW		F5	
	36		ACE01CR1	76	RW	RDI0RO1	B6	RW		F6	
	37		ACE01CR2	77	RW		B7		CPU_F	F7	RL
	38			78			B8			F8	
	39			79			B9			F9	
	3A			7A			BA			FA	
	3B			7B			BB			FB	
	3C			7C			BC			FC	
	3D			7D			BD		DAC_D	FD	RW
	3E			7E			BE		CPU_SCR1	FE	#
	3F			7F			BF		CPU_SCR0	FF	#

Blank fields are Reserved and should not be accessed. # Access is bit specific.

Register Map 1 Table: Configuration Space

Name	Addr (1,Hex)	Access	Name	Addr (1,Hex)	Access	Name	Addr (1,Hex)	Access	Name	Addr (1,Hex)	Access
PRT0DM0	00	RW		40		ASE10CR0	80	RW		C0	
PRT0DM1	01	RW		41			81			C1	
PRT0IC0	02	RW		42			82			C2	
PRT0IC1	03	RW		43			83			C3	
PRT1DM0	04	RW		44		ASE11CR0	84	RW		C4	
PRT1DM1	05	RW		45			85			C5	
PRT1IC0	06	RW		46			86			C6	
PRT1IC1	07	RW		47			87			C7	
PRT2DM0	08	RW		48			88			C8	
PRT2DM1	09	RW		49			89			C9	
PRT2IC0	0A	RW		4A			8A			CA	
PRT2IC1	0B	RW		4B			8B			CB	
PRT3DM0	0C	RW		4C			8C			CC	
PRT3DM1	0D	RW		4D			8D			CD	
PRT3IC0	0E	RW		4E			8E			CE	
PRT3IC1	0F	RW		4F			8F			CF	
	10			50			90		GDI_O_IN	D0	RW
	11			51			91		GDI_E_IN	D1	RW
	12			52			92		GDI_O_OU	D2	RW
	13			53			93		GDI_E_OU	D3	RW
	14			54			94			D4	
	15			55			95			D5	
	16			56			96			D6	
	17			57			97			D7	
	18			58			98		MUX_CR0	D8	RW
	19			59			99		MUX_CR1	D9	RW
	1A			5A			9A		MUX_CR2	DA	RW
	1B			5B			9B		MUX_CR3	DB	RW
	1C			5C			9C			DC	
	1D			5D			9D		OSC_GO_EN	DD	RW
	1E			5E			9E		OSC_CR4	DE	RW
	1F			5F			9F		OSC_CR3	DF	RW
DBB00FN	20	RW	CLK_CR0	60	RW		A0		OSC_CR0	E0	RW
DBB00IN	21	RW	CLK_CR1	61	RW		A1		OSC_CR1	E1	RW
DBB00OU	22	RW	ABF_CR0	62	RW		A2		OSC_CR2	E2	RW
	23		AMD_CR0	63	RW		A3		VLT_CR	E3	RW
DBB01FN	24	RW	CMP_GO_EN	64	RW		A4		VLT_CMP	E4	R
DBB01IN	25	RW		65			A5		ADC0_TR	E5	RW
DBB01OU	26	RW	AMD_CR1	66	RW		A6		ADC1_TR	E6	RW
	27		ALT_CR0	67	RW		A7			E7	
DCB02FN	28	RW		68			A8		IMO_TR	E8	W
DCB02IN	29	RW		69			A9		ILO_TR	E9	W
DCB02OU	2A	RW		6A			AA		BDG_TR	EA	RW
	2B		CLK_CR3	6B	RW		AB		ECO_TR	EB	W
DCB03FN	2C	RW	TMP0_DR	6C	RW		AC			EC	
DCB03IN	2D	RW	TMP1_DR	6D	RW		AD			ED	
DCB03OU	2E	RW	TMP2_DR	6E	RW		AE			EE	
	2F		TMP3_DR	6F	RW		AF			EF	
	30			70		RDI0RI	B0	RW		F0	
	31			71		RDI0SYN	B1	RW		F1	
	32		ACE00CR1	72	RW	RDI0IS	B2	RW		F2	
	33		ACE00CR2	73	RW	RDI0LT0	B3	RW		F3	
	34			74		RDI0LT1	B4	RW		F4	
	35			75		RDI0RO0	B5	RW		F5	
	36		ACE01CR1	76	RW	RDI0RO1	B6	RW		F6	
	37		ACE01CR2	77	RW		B7		CPU_F	F7	RL
	38			78			B8			F8	
	39			79			B9			F9	
	3A			7A			BA		FLS_PR1	FA	RW
	3B			7B			BB			FB	
	3C			7C			BC			FC	
	3D			7D			BD		DAC_CR	FD	RW
	3E			7E			BE		CPU_SCR1	FE	#
	3F			7F			BF		CPU_SCR0	FF	#

Blank fields are Reserved and should not be accessed.

Access is bit specific.

3. Electrical Specifications



This chapter presents the DC and AC electrical specifications of the CY8C21x34 PSoC device. For the most up to date electrical specifications, confirm that you have the most recent data sheet by going to the web at <http://www.cypress.com/psoc>.

Specifications are valid for $-40^{\circ}\text{C} \leq T_A \leq 85^{\circ}\text{C}$ and $T_J \leq 100^{\circ}\text{C}$ as specified, except where noted.

Refer to Table 3-14 for the electrical specifications on the internal main oscillator (IMO) using SLIMO mode.

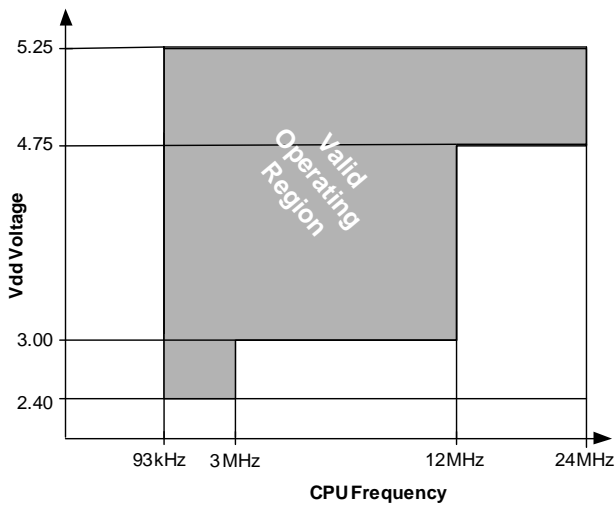

Figure 3-1a. Voltage versus CPU Frequency

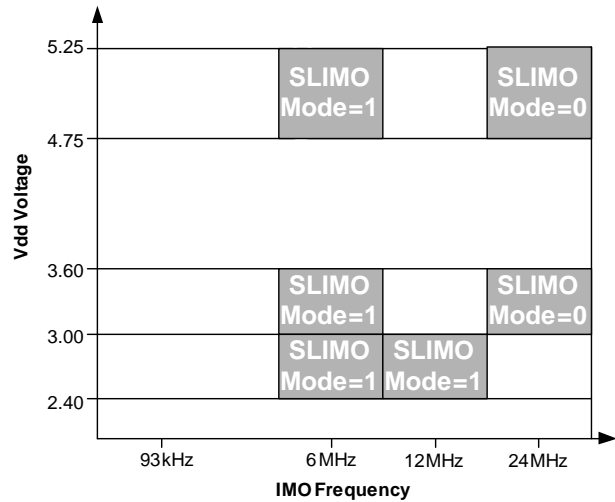

Figure 3-1b. IMO Frequency Trim Options

The following table lists the units of measure that are used in this chapter.

Table 3-1: Units of Measure

Symbol	Unit of Measure	Symbol	Unit of Measure
°C	degree Celsius	μW	microwatts
dB	decibels	mA	milli-ampere
fF	femto farad	ms	milli-second
Hz	hertz	mV	milli-volts
KB	1024 bytes	nA	nanoampere
Kbit	1024 bits	ns	nanosecond
kHz	kilohertz	nV	nanovolts
kΩ	kilohm	Ω	ohm
MHz	megahertz	pA	picoampere
MΩ	megaohm	pF	picofarad
μA	microampere	pp	peak-to-peak
μF	microfarad	ppm	parts per million
μH	microhenry	ps	picosecond
μs	microsecond	sps	samples per second
μV	microvolts	σ	sigma: one standard deviation
μVrms	microvolts root-mean-square	V	volts

3.1 Absolute Maximum Ratings

Table 3-2. Absolute Maximum Ratings

Symbol	Description	Min	Typ	Max	Units	Notes
T _{STG}	Storage Temperature	-55	–	+100	°C	Higher storage temperatures will reduce data retention time.
T _A	Ambient Temperature with Power Applied	-40	–	+85	°C	
V _{DD}	Supply Voltage on V _{DD} Relative to V _{SS}	-0.5	–	+6.0	V	
V _{IO}	DC Input Voltage	V _{SS} - 0.5	–	V _{DD} + 0.5	V	
V _{IOZ}	DC Voltage Applied to Tri-state	V _{SS} - 0.5	–	V _{DD} + 0.5	V	
I _{MIO}	Maximum Current into any Port Pin	-25	–	+50	mA	
ESD	Electro Static Discharge Voltage	2000	–	–	V	Human Body Model ESD.
LU	Latch-up Current	–	–	200	mA	

3.2 Operating Temperature

Table 3-3. Operating Temperature

Symbol	Description	Min	Typ	Max	Units	Notes
T _A	Ambient Temperature	-40	–	+85	°C	
T _J	Junction Temperature	-40	–	+100	°C	The temperature rise from ambient to junction is package specific. See "Thermal Impedances" on page 32. The user must limit the power consumption to comply with this requirement.

3.3 DC Electrical Characteristics

3.3.1 DC Chip-Level Specifications

The following table lists guaranteed maximum and minimum specifications for the voltage and temperature ranges: 4.75V to 5.25V and $-40^{\circ}\text{C} \leq T_A \leq 85^{\circ}\text{C}$, 3.0V to 3.6V and $-40^{\circ}\text{C} \leq T_A \leq 85^{\circ}\text{C}$, or 2.4V to 3.0V and $-40^{\circ}\text{C} \leq T_A \leq 85^{\circ}\text{C}$, respectively. Typical parameters apply to 5V, 3.3V, or 2.7V at 25°C and are for design guidance only.

Table 3-4. DC Chip-Level Specifications

Symbol	Description	Min	Typ	Max	Units	Notes
V _{DD}	Supply Voltage	2.40	–	5.25	V	See table titled "DC POR and LVD Specifications" on page 20.
I _{DD}	Supply Current, IMO = 24 MHz	–	1.7	2.0	mA	Conditions are V _{DD} = 5.0V, T _A = 25°C, CPU = 3 MHz, clock doubler disabled. VC1 = 1.5 MHz, VC2 = 93.75 kHz, VC3 = 0.366 kHz.
I _{DD3}	Supply Current, IMO = 6 MHz using SLIMO mode.	–	1.2	1.4	mA	Conditions are V _{DD} = 3.3V, T _A = 25°C, CPU = 3 MHz, clock doubler disabled. VC1 = 375 kHz, VC2 = 23.4 kHz, VC3 = 0.091 kHz.
I _{DD27}	Supply Current, IMO = 6 MHz using SLIMO mode.	–	1.0	1.2	mA	Conditions are V _{DD} = 2.55V, T _A = 25°C, CPU = 3 MHz, clock doubler disabled. VC1 = 375 kHz, VC2 = 23.4 kHz, VC3 = 0.091 kHz.
I _{SB27}	Sleep (Mode) Current with POR, LVD, Sleep Timer, WDT, and internal slow oscillator active. Mid temperature range.	–	2.4	3.0	μA	V _{DD} = 2.55V, 0°C ≤ T _A ≤ 40°C.
I _{SB}	Sleep (Mode) Current with POR, LVD, Sleep Timer, WDT, and internal slow oscillator active.	–	2.7	3.5	μA	V _{DD} = 3.3V, -40°C ≤ T _A ≤ 85°C.
V _{REF}	Reference Voltage (Bandgap)	1.28	1.30	1.32	V	Trimmed for appropriate V _{DD} . V _{DD} = 3.0V to 5.25V.
V _{REF27}	Reference Voltage (Bandgap)	1.16	1.30	1.33	V	Trimmed for appropriate V _{DD} . V _{DD} = 2.4V to 3.0V.
AGND	Analog Ground	V _{REF} - 0.003	V _{REF}	V _{REF} + 0.003	V	

3.3.2 DC General Purpose IO Specifications

The following tables list guaranteed maximum and minimum specifications for the voltage and temperature ranges: 4.75V to 5.25V and $-40^{\circ}\text{C} \leq T_A \leq 85^{\circ}\text{C}$, 3.0V to 3.6V and $-40^{\circ}\text{C} \leq T_A \leq 85^{\circ}\text{C}$, or 2.4V to 3.0V and $-40^{\circ}\text{C} \leq T_A \leq 85^{\circ}\text{C}$, respectively. Typical parameters apply to 5V, 3.3V, and 2.7V at 25°C and are for design guidance only.

Table 3-5. 5V and 3.3V DC GPIO Specifications

Symbol	Description	Min	Typ	Max	Units	Notes
R _{PU}	Pull-up Resistor	4	5.6	8	k Ω	
R _{PD}	Pull-down Resistor	4	5.6	8	k Ω	
V _{OH}	High Output Level	V _{dd} - 1.0	–	–	V	IOH = 10 mA, V _{dd} = 4.75 to 5.25V (8 total loads, 4 on even port pins (for example, P0[2], P1[4]), 4 on odd port pins (for example, P0[3], P1[5])).
V _{OL}	Low Output Level	–	–	0.75	V	IOL = 25 mA, V _{dd} = 4.75 to 5.25V (8 total loads, 4 on even port pins (for example, P0[2], P1[4]), 4 on odd port pins (for example, P0[3], P1[5])).
V _{IL}	Input Low Level	–	–	0.8	V	V _{dd} = 3.0 to 5.25.
V _{IH}	Input High Level	2.1	–	–	V	V _{dd} = 3.0 to 5.25.
V _H	Input Hysteresis	–	60	–	mV	
I _{IL}	Input Leakage (Absolute Value)	–	1	–	nA	Gross tested to 1 μA .
C _{IN}	Capacitive Load on Pins as Input	–	3.5	10	pF	Package and pin dependent. Temp = 25°C.
C _{OUT}	Capacitive Load on Pins as Output	–	3.5	10	pF	Package and pin dependent. Temp = 25°C.

Table 3-6. 2.7V DC GPIO Specifications

Symbol	Description	Min	Typ	Max	Units	Notes
R _{PU}	Pull-up Resistor	4	5.6	8	k Ω	
R _{PD}	Pull-down Resistor	4	5.6	8	k Ω	
V _{OH}	High Output Level	V _{dd} - 0.4	–	–	V	IOH = 2.5 mA (6.25 Typ), V _{dd} = 2.4 to 3.0V (16 mA maximum, 50 mA Typ combined IOH budget).
V _{OL}	Low Output Level	–	–	0.75	V	IOL = 10 mA, V _{dd} = 2.4 to 3.0V (90 mA maximum combined IOL budget).
V _{IL}	Input Low Level	–	–	0.75	V	V _{dd} = 2.4 to 3.0.
V _{IH}	Input High Level	2.0	–	–	V	V _{dd} = 2.4 to 3.0.
V _H	Input Hysteresis	–	90	–	mV	
I _{IL}	Input Leakage (Absolute Value)	–	1	–	nA	Gross tested to 1 μA .
C _{IN}	Capacitive Load on Pins as Input	–	3.5	10	pF	Package and pin dependent. Temp = 25°C.
C _{OUT}	Capacitive Load on Pins as Output	–	3.5	10	pF	Package and pin dependent. Temp = 25°C.

3.3.3 DC Operational Amplifier Specifications

The following tables list guaranteed maximum and minimum specifications for the voltage and temperature ranges: 4.75V to 5.25V and $-40^{\circ}\text{C} \leq T_A \leq 85^{\circ}\text{C}$, 3.0V to 3.6V and $-40^{\circ}\text{C} \leq T_A \leq 85^{\circ}\text{C}$, or 2.4V to 3.0V and $-40^{\circ}\text{C} \leq T_A \leq 85^{\circ}\text{C}$, respectively. Typical parameters apply to 5V, 3.3V, or 2.7V at 25°C and are for design guidance only.

Table 3-7. 5V DC Operational Amplifier Specifications

Symbol	Description	Min	Typ	Max	Units	Notes
V _{OSOA}	Input Offset Voltage (absolute value)	–	2.5	15	mV	
TCV _{OSOA}	Average Input Offset Voltage Drift	–	10	–	$\mu\text{V}/^{\circ}\text{C}$	
I _{EBOA}	Input Leakage Current (Port 0 Analog Pins)	–	200	–	pA	Gross tested to 1 μA .
C _{INOA}	Input Capacitance (Port 0 Analog Pins)	–	4.5	9.5	pF	Package and pin dependent. Temp = 25°C .
V _{CMOA}	Common Mode Voltage Range	0.0	–	V _{dd} - 1	V	
G _{OLOA}	Open Loop Gain	–	80	–	dB	
I _{SOA}	Amplifier Supply Current	–	10	30	μA	

Table 3-8. 3.3V DC Operational Amplifier Specifications

Symbol	Description	Min	Typ	Max	Units	Notes
V _{OSOA}	Input Offset Voltage (absolute value)	–	2.5	15	mV	
TCV _{OSOA}	Average Input Offset Voltage Drift	–	10	–	$\mu\text{V}/^{\circ}\text{C}$	
I _{EBOA}	Input Leakage Current (Port 0 Analog Pins)	–	200	–	pA	Gross tested to 1 μA .
C _{INOA}	Input Capacitance (Port 0 Analog Pins)	–	4.5	9.5	pF	Package and pin dependent. Temp = 25°C .
V _{CMOA}	Common Mode Voltage Range	0	–	V _{dd} - 1	V	
G _{OLOA}	Open Loop Gain	–	80	–	dB	
I _{SOA}	Amplifier Supply Current	–	10	30	μA	

Table 3-9. 2.7V DC Operational Amplifier Specifications

Symbol	Description	Min	Typ	Max	Units	Notes
V _{OSOA}	Input Offset Voltage (absolute value)	–	2.5	15	mV	
TCV _{OSOA}	Average Input Offset Voltage Drift	–	10	–	$\mu\text{V}/^{\circ}\text{C}$	
I _{EBOA}	Input Leakage Current (Port 0 Analog Pins)	–	200	–	pA	Gross tested to 1 μA .
C _{INOA}	Input Capacitance (Port 0 Analog Pins)	–	4.5	9.5	pF	Package and pin dependent. Temp = 25°C .
V _{CMOA}	Common Mode Voltage Range	0	–	V _{dd} - 1	V	
G _{OLOA}	Open Loop Gain	–	80	–	dB	
I _{SOA}	Amplifier Supply Current	–	10	30	μA	

3.3.4 DC Switch Mode Pump Specifications

The following table lists guaranteed maximum and minimum specifications for the voltage and temperature ranges: 4.75V to 5.25V and $-40^{\circ}\text{C} \leq T_A \leq 85^{\circ}\text{C}$, 3.0V to 3.6V and $-40^{\circ}\text{C} \leq T_A \leq 85^{\circ}\text{C}$, or 2.4V to 3.0V and $-40^{\circ}\text{C} \leq T_A \leq 85^{\circ}\text{C}$, respectively. Typical parameters apply to 5V, 3.3V, or 2.7V at 25°C and are for design guidance only.

Table 3-10. DC Switch Mode Pump (SMP) Specifications

Symbol	Description	Min	Typ	Max	Units	Notes
V _{PUMP5V}	5V Output Voltage from Pump	4.75	5.0	5.25	V	Configuration of footnote. ^a Average, neglecting ripple. SMP trip voltage is set to 5.0V.
V _{PUMP3V}	3.3V Output Voltage from Pump	3.00	3.25	3.60	V	Configuration of footnote. ^a Average, neglecting ripple. SMP trip voltage is set to 3.25V.
V _{PUMP2V}	2.6V Output Voltage from Pump	2.45	2.55	2.80	V	Configuration of footnote. ^a Average, neglecting ripple. SMP trip voltage is set to 2.55V.
I _{PUMP}	Available Output Current V _{BAT} = 1.8V, V _{PUMP} = 5.0V V _{BAT} = 1.5V, V _{PUMP} = 3.25V V _{BAT} = 1.3V, V _{PUMP} = 2.55V	5 8 8	– – –	– – –	mA mA mA	Configuration of footnote. ^a SMP trip voltage is set to 5.0V. SMP trip voltage is set to 3.25V. SMP trip voltage is set to 2.55V.
V _{BAT5V}	Input Voltage Range from Battery	1.8	–	5.0	V	Configuration of footnote. ^a SMP trip voltage is set to 5.0V.
V _{BAT3V}	Input Voltage Range from Battery	1.0	–	3.3	V	Configuration of footnote. ^a SMP trip voltage is set to 3.25V.
V _{BAT2V}	Input Voltage Range from Battery	1.0	–	2.8	V	Configuration of footnote. ^a SMP trip voltage is set to 2.55V.
V _{BATSTART}	Minimum Input Voltage from Battery to Start Pump	1.2	–	–	V	Configuration of footnote. ^a $0^{\circ}\text{C} \leq T_A \leq 100^{\circ}\text{C}$. 1.25V at $T_A = -40^{\circ}\text{C}$.
$\Delta V_{\text{PUMP_Line}}$	Line Regulation (over V _i range)	–	5	–	%V _O	Configuration of footnote. ^a V _O is the "V _{dd} Value for PUMP Trip" specified by the VM[2:0] setting in the DC POR and LVD Specification, Table 3-12 on page 20 .
$\Delta V_{\text{PUMP_Load}}$	Load Regulation	–	5	–	%V _O	Configuration of footnote. ^a V _O is the "V _{dd} Value for PUMP Trip" specified by the VM[2:0] setting in the DC POR and LVD Specification, Table 3-12 on page 20 .
$\Delta V_{\text{PUMP_Ripple}}$	Output Voltage Ripple (depends on cap/load)	–	100	–	mVpp	Configuration of footnote. ^a Load is 5 mA.
E ₃	Efficiency	35	50	–	%	Configuration of footnote. ^a Load is 5 mA. SMP trip voltage is set to 3.25V.
E ₂	Efficiency	35	80	–	%	For I load = 1mA, V _{PUMP} = 2.55V, V _{BAT} = 1.3V, 10 uH inductor, 1 uF capacitor, and Schottky diode.
F _{PUMP}	Switching Frequency	–	1.3	–	MHz	
DC _{PUMP}	Switching Duty Cycle	–	50	–	%	

a. L₁ = 2 μH inductor, C₁ = 10 μF capacitor, D₁ = Schottky diode. See Figure 3-2.

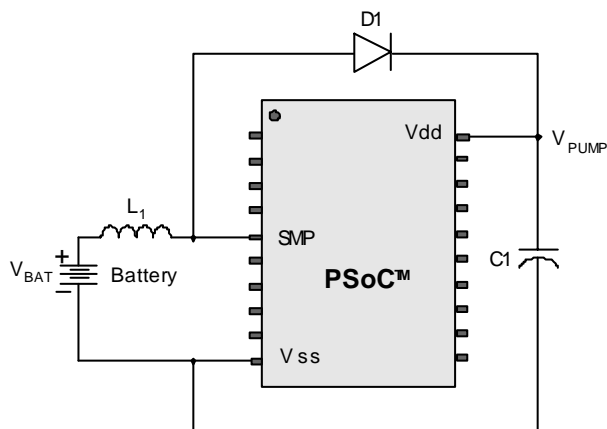

Figure 3-2. Basic Switch Mode Pump Circuit

3.3.5 DC Analog Mux Bus Specifications

The following table lists guaranteed maximum and minimum specifications for the voltage and temperature ranges: 4.75V to 5.25V and $-40^{\circ}\text{C} \leq T_A \leq 85^{\circ}\text{C}$, 3.0V to 3.6V and $-40^{\circ}\text{C} \leq T_A \leq 85^{\circ}\text{C}$, or 2.4V to 3.0V and $-40^{\circ}\text{C} \leq T_A \leq 85^{\circ}\text{C}$, respectively. Typical parameters apply to 5V, 3.3V, or 2.7V at 25°C and are for design guidance only.

Table 3-11. DC Analog Mux Bus Specifications

Symbol	Description	Min	Typ	Max	Units	Notes
R _{SW}	Switch Resistance to Common Analog Bus	–	–	400 800	Ω Ω	V _{dd} ≥ 2.7V 2.4V ≤ V _{dd} ≤ 2.7V
R _{VDD}	Resistance of Initialization Switch to V _{dd}	–	–	800	Ω	

3.3.6 DC POR and LVD Specifications

The following table lists guaranteed maximum and minimum specifications for the voltage and temperature ranges: 4.75V to 5.25V and $-40^{\circ}\text{C} \leq T_A \leq 85^{\circ}\text{C}$, 3.0V to 3.6V and $-40^{\circ}\text{C} \leq T_A \leq 85^{\circ}\text{C}$, or 2.4V to 3.0V and $-40^{\circ}\text{C} \leq T_A \leq 85^{\circ}\text{C}$, respectively. Typical parameters apply to 5V, 3.3V, or 2.7V at 25°C and are for design guidance only.

Table 3-12. DC POR and LVD Specifications

Symbol	Description	Min	Typ	Max	Units	Notes
V _{PPOR0}	V _{dd} Value for PPOR Trip PORLEV[1:0] = 00b		2.36	2.40	V	V _{dd} must be greater than or equal to 2.5V during startup, reset from the XRES pin, or reset from Watchdog.
V _{PPOR1}	PORLEV[1:0] = 01b	–	2.82	2.95	V	
V _{PPOR2}	PORLEV[1:0] = 10b		4.55	4.70	V	
V _{LVD0}	V _{dd} Value for LVD Trip VM[2:0] = 000b	2.40	2.45	2.51 ^a	V	
V _{LVD1}	VM[2:0] = 001b	2.85	2.92	2.99 ^b	V	
V _{LVD2}	VM[2:0] = 010b	2.95	3.02	3.09	V	
V _{LVD3}	VM[2:0] = 011b	3.06	3.13	3.20	V	
V _{LVD4}	VM[2:0] = 100b	4.37	4.48	4.55	V	
V _{LVD5}	VM[2:0] = 101b	4.50	4.64	4.75	V	
V _{LVD6}	VM[2:0] = 110b	4.62	4.73	4.83	V	
V _{LVD7}	VM[2:0] = 111b	4.71	4.81	4.95	V	
V _{PUMP0}	V _{dd} Value for PUMP Trip VM[2:0] = 000b	2.45	2.55	2.62 ^c	V	
V _{PUMP1}	VM[2:0] = 001b	2.96	3.02	3.09	V	
V _{PUMP2}	VM[2:0] = 010b	3.03	3.10	3.16	V	
V _{PUMP3}	VM[2:0] = 011b	3.18	3.25	3.32 ^d	V	
V _{PUMP4}	VM[2:0] = 100b	4.54	4.64	4.74	V	
V _{PUMP5}	VM[2:0] = 101b	4.62	4.73	4.83	V	
V _{PUMP6}	VM[2:0] = 110b	4.71	4.82	4.92	V	
V _{PUMP7}	VM[2:0] = 111b	4.89	5.00	5.12	V	

- Always greater than 50 mV above V_{PPOR} (PORLEV = 00) for falling supply.
- Always greater than 50 mV above V_{PPOR} (PORLEV = 01) for falling supply.
- Always greater than 50 mV above V_{LVD0}.
- Always greater than 50 mV above V_{LVD3}.

3.3.7 DC Programming Specifications

The following table lists guaranteed maximum and minimum specifications for the voltage and temperature ranges: 4.75V to 5.25V and $-40^{\circ}\text{C} \leq T_A \leq 85^{\circ}\text{C}$, 3.0V to 3.6V and $-40^{\circ}\text{C} \leq T_A \leq 85^{\circ}\text{C}$, or 2.4V to 3.0V and $-40^{\circ}\text{C} \leq T_A \leq 85^{\circ}\text{C}$, respectively. Typical parameters apply to 5V, 3.3V, or 2.7V at 25°C and are for design guidance only.

Table 3-13. DC Programming Specifications

Symbol	Description	Min	Typ	Max	Units	Notes
VddIWRITE	Supply Voltage for Flash Write Operations	2.70	–	–	V	
IDDP	Supply Current During Programming or Verify	–	5	25	mA	
VILP	Input Low Voltage During Programming or Verify	–	–	0.8	V	
VIHP	Input High Voltage During Programming or Verify	2.2	–	–	V	
IILP	Input Current when Applying Vilp to P1[0] or P1[1] During Programming or Verify	–	–	0.2	mA	Driving internal pull-down resistor.
IIHP	Input Current when Applying Vihp to P1[0] or P1[1] During Programming or Verify	–	–	1.5	mA	Driving internal pull-down resistor.
VOLV	Output Low Voltage During Programming or Verify	–	–	Vss + 0.75	V	
VOHV	Output High Voltage During Programming or Verify	Vdd - 1.0	–	Vdd	V	
FlashENPB	Flash Endurance (per block)	50,000	–	–	–	Erase/write cycles per block.
FlashENT	Flash Endurance (total) ^a	1,800,000	–	–	–	Erase/write cycles.
FlashDR	Flash Data Retention	10	–	–	Years	

- a. A maximum of 36 x 50,000 block endurance cycles is allowed. This may be balanced between operations on 36x1 blocks of 50,000 maximum cycles each, 36x2 blocks of 25,000 maximum cycles each, or 36x4 blocks of 12,500 maximum cycles each (to limit the total number of cycles to 36x50,000 and that no single block ever sees more than 50,000 cycles).

For the full industrial range, the user must employ a temperature sensor user module (FlashTemp) and feed the result to the temperature argument before writing. Refer to the Flash APIs Application Note AN2015 at <http://www.cypress.com> under Application Notes for more information.

3.4 AC Electrical Characteristics

3.4.1 AC Chip-Level Specifications

The following tables list guaranteed maximum and minimum specifications for the voltage and temperature ranges: 4.75V to 5.25V and $-40^{\circ}\text{C} \leq T_A \leq 85^{\circ}\text{C}$, 3.0V to 3.6V and $-40^{\circ}\text{C} \leq T_A \leq 85^{\circ}\text{C}$, or 2.4V to 3.0V and $-40^{\circ}\text{C} \leq T_A \leq 85^{\circ}\text{C}$, respectively. Typical parameters apply to 5V, 3.3V, or 2.7V at 25°C and are for design guidance only.

Table 3-14. 5V and 3.3V AC Chip-Level Specifications

Symbol	Description	Min	Typ	Max	Units	Notes
FIMO24	Internal Main Oscillator Frequency for 24 MHz	23.4	24	24.6 ^{a,b,c}	MHz	Trimmed for 5V or 3.3V operation using factory trim values. See Figure 3-1b on page 15. SLIMO mode = 0.
FIMO6	Internal Main Oscillator Frequency for 6 MHz	5.75	6	6.35 ^{a,b,c}	MHz	Trimmed for 5V or 3.3V operation using factory trim values. See Figure 3-1b on page 15. SLIMO mode = 1.
FCPU1	CPU Frequency (5V Nominal)	0.93	24	24.6 ^{a,b}	MHz	24 MHz only for SLIMO mode = 0.
FCPU2	CPU Frequency (3.3V Nominal)	0.93	12	12.3 ^{b,c}	MHz	
FBLK5	Digital PSoC Block Frequency (5V Nominal)	0	48	49.2 ^{a,b,d}	MHz	Refer to the AC Digital Block Specifications below.
FBLK33	Digital PSoC Block Frequency (3.3V Nominal)	0	24	24.6 ^{b,d}	MHz	
F32K1	Internal Low Speed Oscillator Frequency	15	32	64	kHz	
Jitter32k	32 kHz Period Jitter	–	100	200	ns	
TXRST	External Reset Pulse Width	10	–	–	μs	
DC24M	24 MHz Duty Cycle	40	50	60	%	
Step24M	24 MHz Trim Step Size	–	50	–	kHz	
Fout48M	48 MHz Output Frequency	46.8	48.0	49.2 ^{a,c}	MHz	Trimmed. Utilizing factory trim values.
Jitter24M1	24 MHz Period Jitter (IMO)	–	600	–	ps	
FMAX	Maximum frequency of signal on row input or row output.	–	–	12.3	MHz	
TRAMP	Supply Ramp Time	0	–	–	μs	

- 4.75V < Vdd < 5.25V.
- Accuracy derived from Internal Main Oscillator with appropriate trim for Vdd range.
- 3.0V < Vdd < 3.6V. See Application Note AN2012 "Adjusting PSoC Microcontroller Trims for Dual Voltage-Range Operation" for information on trimming for operation at 3.3V.
- See the individual user module data sheets for information on maximum frequencies for user modules.

Table 3-15. 2.7V AC Chip-Level Specifications

Symbol	Description	Min	Typ	Max	Units	Notes
FIMO12	Internal Main Oscillator Frequency for 12 MHz	11.5	12	12.7 ^{a,b,c}	MHz	Trimmed for 2.7V operation using factory trim values. See Figure 3-1b on page 15. SLIMO mode = 1.
FIMO6	Internal Main Oscillator Frequency for 6 MHz	5.75	6	6.35 ^{a,b,c}	MHz	Trimmed for 2.7V operation using factory trim values. See Figure 3-1b on page 15. SLIMO mode = 1.
FCPU1	CPU Frequency (2.7V Nominal)	0.093	3	3.15 ^{a,b}	MHz	24 MHz only for SLIMO mode = 0.
FBLK27	Digital PSoC Block Frequency (2.7V Nominal)	0	12	12.5 ^{a,b,c}	MHz	Refer to the AC Digital Block Specifications below.
F32K1	Internal Low Speed Oscillator Frequency	8	32	96	kHz	
Jitter32k	32 kHz Period Jitter	–	150	200	ns	
TXRST	External Reset Pulse Width	10	–	–	μs	
FMAX	Maximum frequency of signal on row input or row output.	–	–	12.3	MHz	
TRAMP	Supply Ramp Time	0	–	–	μs	

- 2.4V < Vdd < 3.0V.
- Accuracy derived from Internal Main Oscillator with appropriate trim for Vdd range.
- See Application Note AN2012 "Adjusting PSoC Microcontroller Trims for Dual Voltage-Range Operation" for information on maximum frequency for user modules.

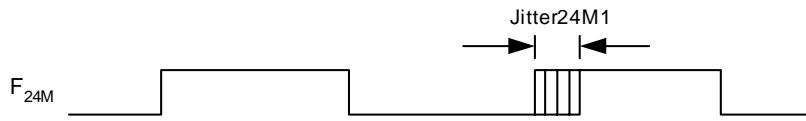

Figure 3-3. 24 MHz Period Jitter (IMO) Timing Diagram

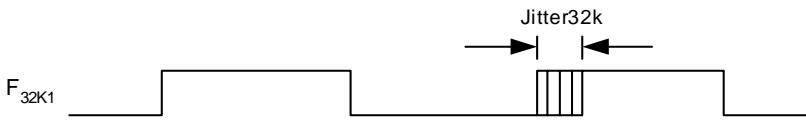

Figure 3-4. 32 kHz Period Jitter (ILO) Timing Diagram

3.4.2 AC General Purpose IO Specifications

The following tables list guaranteed maximum and minimum specifications for the voltage and temperature ranges: 4.75V to 5.25V and $-40^{\circ}\text{C} \leq T_A \leq 85^{\circ}\text{C}$, 3.0V to 3.6V and $-40^{\circ}\text{C} \leq T_A \leq 85^{\circ}\text{C}$, or 2.4V to 3.0V and $-40^{\circ}\text{C} \leq T_A \leq 85^{\circ}\text{C}$, respectively. Typical parameters apply to 5V, 3.3V, or 2.7V at 25°C and are for design guidance only.

Table 3-16. 5V and 3.3V AC GPIO Specifications

Symbol	Description	Min	Typ	Max	Units	Notes
F _{GPIO}	GPIO Operating Frequency	0	–	12	MHz	Normal Strong Mode
T _{RiseF}	Rise Time, Normal Strong Mode, Cload = 50 pF	3	–	18	ns	V _{dd} = 4.5 to 5.25V, 10% - 90%
T _{FallF}	Fall Time, Normal Strong Mode, Cload = 50 pF	2	–	18	ns	V _{dd} = 4.5 to 5.25V, 10% - 90%
T _{RiseS}	Rise Time, Slow Strong Mode, Cload = 50 pF	7	27	–	ns	V _{dd} = 3 to 5.25V, 10% - 90%
T _{FallS}	Fall Time, Slow Strong Mode, Cload = 50 pF	7	22	–	ns	V _{dd} = 3 to 5.25V, 10% - 90%

Table 3-17. 2.7V AC GPIO Specifications

Symbol	Description	Min	Typ	Max	Units	Notes
F _{GPIO}	GPIO Operating Frequency	0	–	3	MHz	Normal Strong Mode
T _{RiseF}	Rise Time, Normal Strong Mode, Cload = 50 pF	6	–	50	ns	V _{dd} = 2.4 to 3.0V, 10% - 90%
T _{FallF}	Fall Time, Normal Strong Mode, Cload = 50 pF	6	–	50	ns	V _{dd} = 2.4 to 3.0V, 10% - 90%
T _{RiseS}	Rise Time, Slow Strong Mode, Cload = 50 pF	18	40	120	ns	V _{dd} = 2.4 to 3.0V, 10% - 90%
T _{FallS}	Fall Time, Slow Strong Mode, Cload = 50 pF	18	40	120	ns	V _{dd} = 2.4 to 3.0V, 10% - 90%

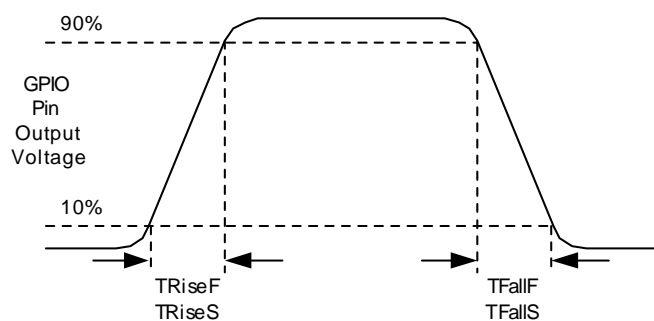

Figure 3-5. GPIO Timing Diagram

3.4.3 AC Operational Amplifier Specifications

The following table lists guaranteed maximum and minimum specifications for the voltage and temperature ranges: 4.75V to 5.25V and $-40^{\circ}\text{C} \leq T_A \leq 85^{\circ}\text{C}$, 3.0V to 3.6V and $-40^{\circ}\text{C} \leq T_A \leq 85^{\circ}\text{C}$, or 2.4V to 3.0V and $-40^{\circ}\text{C} \leq T_A \leq 85^{\circ}\text{C}$, respectively. Typical parameters apply to 5V, 3.3V, or 2.7V at 25°C and are for design guidance only.

Table 3-18. AC Operational Amplifier Specifications

Symbol	Description	Min	Typ	Max	Units	Notes
T _{COMP}	Comparator Mode Response Time, 50 mV Overdrive			100 200	ns ns	V _{DD} ≥ 3.0V. 2.4V < V _{CC} < 3.0V.

3.4.4 AC Analog Mux Bus Specifications

The following table lists guaranteed maximum and minimum specifications for the voltage and temperature ranges: 4.75V to 5.25V and $-40^{\circ}\text{C} \leq T_A \leq 85^{\circ}\text{C}$, 3.0V to 3.6V and $-40^{\circ}\text{C} \leq T_A \leq 85^{\circ}\text{C}$, or 2.4V to 3.0V and $-40^{\circ}\text{C} \leq T_A \leq 85^{\circ}\text{C}$, respectively. Typical parameters apply to 5V, 3.3V, or 2.7V at 25°C and are for design guidance only.

Table 3-19. AC Analog Mux Bus Specifications

Symbol	Description	Min	Typ	Max	Units	Notes
F _{SW}	Switch Rate	–	–	3.17	MHz	

3.4.5 AC Digital Block Specifications

The following tables list guaranteed maximum and minimum specifications for the voltage and temperature ranges: 4.75V to 5.25V and $-40^{\circ}\text{C} \leq T_A \leq 85^{\circ}\text{C}$, 3.0V to 3.6V and $-40^{\circ}\text{C} \leq T_A \leq 85^{\circ}\text{C}$, or 2.4V to 3.0V and $-40^{\circ}\text{C} \leq T_A \leq 85^{\circ}\text{C}$, respectively. Typical parameters apply to 5V, 3.3V, or 2.7V at 25°C and are for design guidance only.

Table 3-20. 5V and 3.3V AC Digital Block Specifications

Function	Description	Min	Typ	Max	Units	Notes
All Functions	Maximum Block Clocking Frequency (> 4.75V)			49.2	MHz	4.75V < V _{DD} < 5.25V.
	Maximum Block Clocking Frequency (< 4.75V)			24.6	MHz	3.0V < V _{DD} < 4.75V.
Timer	Capture Pulse Width	50 ^a	–	–	ns	
	Maximum Frequency, No Capture	–	–	49.2	MHz	4.75V < V _{DD} < 5.25V.
	Maximum Frequency, With or Without Capture	–	–	24.6	MHz	
Counter	Enable Pulse Width	50	–	–	ns	
	Maximum Frequency, No Enable Input	–	–	49.2	MHz	4.75V < V _{DD} < 5.25V.
	Maximum Frequency, Enable Input	–	–	24.6	MHz	
Dead Band	Kill Pulse Width:					
	Asynchronous Restart Mode	20	–	–	ns	
	Synchronous Restart Mode	50	–	–	ns	
	Disable Mode	50	–	–	ns	
	Maximum Frequency	–	–	49.2	MHz	4.75V < V _{DD} < 5.25V.
CRCPRS (PRS Mode)	Maximum Input Clock Frequency	–	–	49.2	MHz	4.75V < V _{DD} < 5.25V.
CRCPRS (CRC Mode)	Maximum Input Clock Frequency	–	–	24.6	MHz	
SPIM	Maximum Input Clock Frequency	–	–	8.2	MHz	Maximum data rate at 4.1 MHz due to 2 x over clocking.
SPIS	Maximum Input Clock Frequency	–	–	4.1	MHz	
	Width of SS_ Negated Between Transmissions	50	–	–	ns	
Transmitter	Maximum Input Clock Frequency	–	–	24.6	MHz	Maximum data rate at 3.08 MHz due to 8 x over clocking.
Receiver	Maximum Input Clock Frequency	–	–	24.6	MHz	Maximum data rate at 3.08 MHz due to 8 x over clocking.

a. 50 ns minimum input pulse width is based on the input synchronizers running at 12 MHz (84 ns nominal period).

Table 3-21. 2.7V AC Digital Block Specifications

Function	Description	Min	Typ	Max	Units	Notes
All Functions	Maximum Block Clocking Frequency			12.7	MHz	2.4V < Vdd < 3.0V.
Timer	Capture Pulse Width	100 ^a	–	–	ns	
	Maximum Frequency, With or Without Capture	–	–	12.7	MHz	
Counter	Enable Pulse Width	100	–	–	ns	
	Maximum Frequency, No Enable Input	–	–	12.7	MHz	
	Maximum Frequency, Enable Input	–	–	12.7	MHz	
Dead Band	Kill Pulse Width:					
	Asynchronous Restart Mode	20	–	–	ns	
	Synchronous Restart Mode	100	–	–	ns	
	Disable Mode	100	–	–	ns	
	Maximum Frequency	–	–	12.7	MHz	
CRCPRS (PRS Mode)	Maximum Input Clock Frequency	–	–	12.7	MHz	
CRCPRS (CRC Mode)	Maximum Input Clock Frequency	–	–	12.7	MHz	
SPIIM	Maximum Input Clock Frequency	–	–	6.35	MHz	Maximum data rate at 3.17 MHz due to 2 x over clocking.
SPIS	Maximum Input Clock Frequency	–	–	4.1	MHz	
	Width of SS_ Negated Between Transmissions	100	–	–	ns	
Transmitter	Maximum Input Clock Frequency	–	–	12.7	MHz	Maximum data rate at 1.59 MHz due to 8 x over clocking.
Receiver	Maximum Input Clock Frequency	–	–	12.7	MHz	Maximum data rate at 1.59 MHz due to 8 x over clocking.

a. 100 ns minimum input pulse width is based on the input synchronizers running at 12 MHz (84 ns nominal period).

3.4.6 AC External Clock Specifications

The following tables list guaranteed maximum and minimum specifications for the voltage and temperature ranges: 4.75V to 5.25V and $-40^{\circ}\text{C} \leq T_A \leq 85^{\circ}\text{C}$, or 3.0V to 3.6V and $-40^{\circ}\text{C} \leq T_A \leq 85^{\circ}\text{C}$, respectively. Typical parameters apply to 5V, 3.3V, or 2.7V at 25°C and are for design guidance only.

Table 3-22. 5V AC External Clock Specifications

Symbol	Description	Min	Typ	Max	Units	Notes
FOSCEXT	Frequency	0.093	–	24.6	MHz	
–	High Period	20.6	–	5300	ns	
–	Low Period	20.6	–	–	ns	
–	Power Up IMO to Switch	150	–	–	μs	

Table 3-23. 3.3V AC External Clock Specifications

Symbol	Description	Min	Typ	Max	Units	Notes
FOSCEXT	Frequency with CPU Clock divide by 1	0.093	–	12.3	MHz	Maximum CPU frequency is 12 MHz at 3.3V. With the CPU clock divider set to 1, the external clock must adhere to the maximum frequency and duty cycle requirements.
FOSCEXT	Frequency with CPU Clock divide by 2 or greater	0.186	–	24.6	MHz	If the frequency of the external clock is greater than 12 MHz, the CPU clock divider must be set to 2 or greater. In this case, the CPU clock divider will ensure that the fifty percent duty cycle requirement is met.
–	High Period with CPU Clock divide by 1	41.7	–	5300	ns	
–	Low Period with CPU Clock divide by 1	41.7	–	–	ns	
–	Power Up IMO to Switch	150	–	–	μs	

Table 3-24. 2.7V AC External Clock Specifications

Symbol	Description	Min	Typ	Max	Units	Notes
FOSCEXT	Frequency with CPU Clock divide by 1	0.093	–	3.08	MHz	Maximum CPU frequency is 3 MHz at 2.7V. With the CPU clock divider set to 1, the external clock must adhere to the maximum frequency and duty cycle requirements.
FOSCEXT	Frequency with CPU Clock divide by 2 or greater	0.186	–	6.35	MHz	If the frequency of the external clock is greater than 3 MHz, the CPU clock divider must be set to 2 or greater. In this case, the CPU clock divider will ensure that the fifty percent duty cycle requirement is met.
–	High Period with CPU Clock divide by 1	160	–	5300	ns	
–	Low Period with CPU Clock divide by 1	160	–	–	ns	
–	Power Up IMO to Switch	150	–	–	μs	

3.4.7 AC Programming Specifications

The following table lists guaranteed maximum and minimum specifications for the voltage and temperature ranges: 4.75V to 5.25V and $-40^{\circ}\text{C} \leq T_A \leq 85^{\circ}\text{C}$, or 3.0V to 3.6V and $-40^{\circ}\text{C} \leq T_A \leq 85^{\circ}\text{C}$, respectively. Typical parameters apply to 5V, 3.3V, or 2.7V at 25°C and are for design guidance only.

Table 3-25. AC Programming Specifications

Symbol	Description	Min	Typ	Max	Units	Notes
T _R SCLK	Rise Time of SCLK	1	–	20	ns	
T _F SCLK	Fall Time of SCLK	1	–	20	ns	
T _S SCLK	Data Set up Time to Falling Edge of SCLK	40	–	–	ns	
T _H SCLK	Data Hold Time from Falling Edge of SCLK	40	–	–	ns	
F _S CLK	Frequency of SCLK	0	–	8	MHz	
T _{ERASEB}	Flash Erase Time (Block)	–	15	–	ms	
T _{WRITE}	Flash Block Write Time	–	30	–	ms	
T _D SCLK	Data Out Delay from Falling Edge of SCLK	–	–	45	ns	3.6 < V _{dd}
T _D SCLK3	Data Out Delay from Falling Edge of SCLK	–	–	50	ns	3.0 ≤ V _{dd} ≤ 3.6
T _D SCLK2	Data Out Delay from Falling Edge of SCLK	–	–	70	ns	2.4 ≤ V _{dd} ≤ 3.0

3.4.8 AC I²C Specifications

The following tables list guaranteed maximum and minimum specifications for the voltage and temperature ranges: 4.75V to 5.25V and $-40^{\circ}\text{C} \leq T_A \leq 85^{\circ}\text{C}$, 3.0V to 3.6V and $-40^{\circ}\text{C} \leq T_A \leq 85^{\circ}\text{C}$, or 2.4V to 3.0V and $-40^{\circ}\text{C} \leq T_A \leq 85^{\circ}\text{C}$, respectively. Typical parameters apply to 5V, 3.3V, or 2.7V at 25°C and are for design guidance only.

Table 3-26. AC Characteristics of the I²C SDA and SCL Pins for V_{dd} ≥ 3.0V

Symbol	Description	Standard Mode		Fast Mode		Units	Notes
		Min	Max	Min	Max		
F _S CL _{I2C}	SCL Clock Frequency	0	100	0	400	kHz	
T _H DSTAI _{2C}	Hold Time (repeated) START Condition. After this period, the first clock pulse is generated.	4.0	–	0.6	–	μs	
T _L OWI _{2C}	LOW Period of the SCL Clock	4.7	–	1.3	–	μs	
T _H HIGHI _{2C}	HIGH Period of the SCL Clock	4.0	–	0.6	–	μs	
T _S USTAI _{2C}	Set-up Time for a Repeated START Condition	4.7	–	0.6	–	μs	
T _H DDATI _{2C}	Data Hold Time	0	–	0	–	μs	
T _S UDATI _{2C}	Data Set-up Time	250	–	100 ^a	–	ns	
T _S USTOI _{2C}	Set-up Time for STOP Condition	4.0	–	0.6	–	μs	
T _B UFI _{2C}	Bus Free Time Between a STOP and START Condition	4.7	–	1.3	–	μs	
T _S PI _{2C}	Pulse Width of spikes are suppressed by the input filter.	–	–	0	50	ns	

- a. A Fast-Mode I²C-bus device can be used in a Standard-Mode I²C-bus system, but the requirement t_{SU, DAT} ≥ 250 ns must then be met. This will automatically be the case if the device does not stretch the LOW period of the SCL signal. If such device does stretch the LOW period of the SCL signal, it must output the next data bit to the SDA line t_{rmax} + t_{SU, DAT} = 1000 + 250 = 1250 ns (according to the Standard-Mode I²C-bus specification) before the SCL line is released.

Table 3-27. 2.7V AC Characteristics of the I²C SDA and SCL Pins (Fast Mode not Supported)

Symbol	Description	Standard Mode		Fast Mode		Units	Notes
		Min	Max	Min	Max		
F _S CL _{I2C}	SCL Clock Frequency	0	100	–	–	kHz	
T _H DSTAI _{2C}	Hold Time (repeated) START Condition. After this period, the first clock pulse is generated.	4.0	–	–	–	μs	
T _L OWI _{2C}	LOW Period of the SCL Clock	4.7	–	–	–	μs	
T _H HIGHI _{2C}	HIGH Period of the SCL Clock	4.0	–	–	–	μs	
T _S USTAI _{2C}	Set-up Time for a Repeated START Condition	4.7	–	–	–	μs	
T _H DDATI _{2C}	Data Hold Time	0	–	–	–	μs	

Table 3-27. 2.7V AC Characteristics of the I²C SDA and SCL Pins (Fast Mode not Supported) (continued)

Symbol	Description	Standard Mode		Fast Mode		Units	Notes
		Min	Max	Min	Max		
T _{SUDATI2C}	Data Set-up Time	250	–	–	–	ns	
T _{SUSTOI2C}	Set-up Time for STOP Condition	4.0	–	–	–	μs	
T _{BUF12C}	Bus Free Time Between a STOP and START Condition	4.7	–	–	–	μs	
T _{SPI2C}	Pulse Width of spikes are suppressed by the input filter.	–	–	–	–	ns	

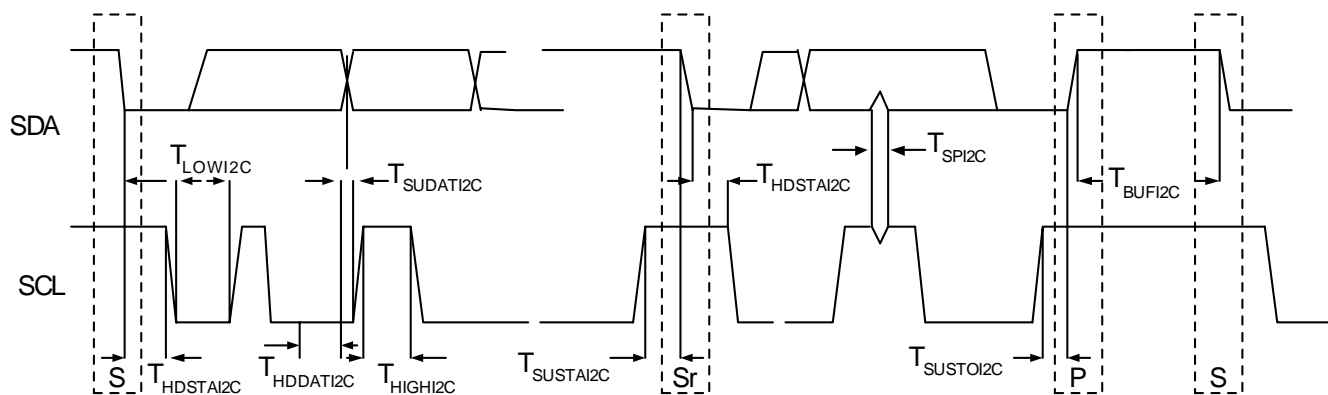

Figure 3-6. Definition for Timing for Fast/Standard Mode on the I²C Bus

4. Packaging Information



This chapter illustrates the packaging specifications for the CY8C21x34 PSoC device, along with the thermal impedances for each package.

Important Note Emulation tools may require a larger area on the target PCB than the chip's footprint. For a detailed description of the emulation tools' dimensions, refer to the document titled *PSoC Emulator Pod Dimensions* at <http://www.cypress.com/support/link.cfm?mr=poddim>.

4.1 Packaging Dimensions

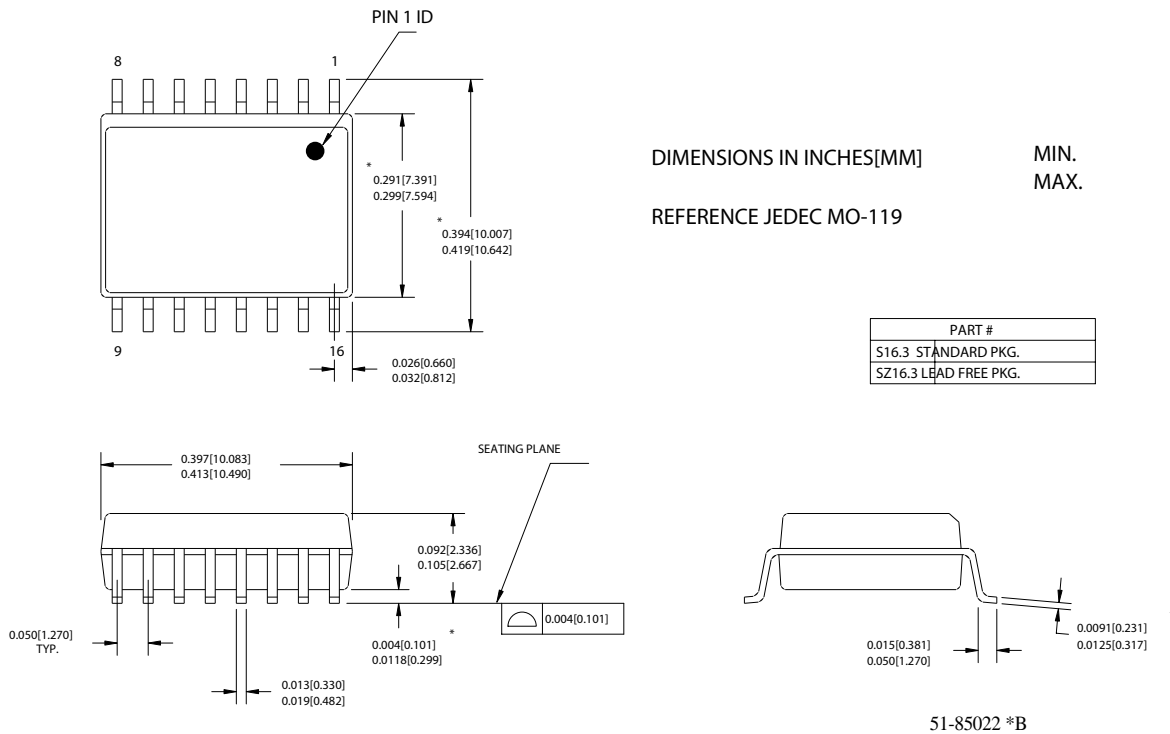

Figure 4-1. 16-Lead (150-Mil) SOIC

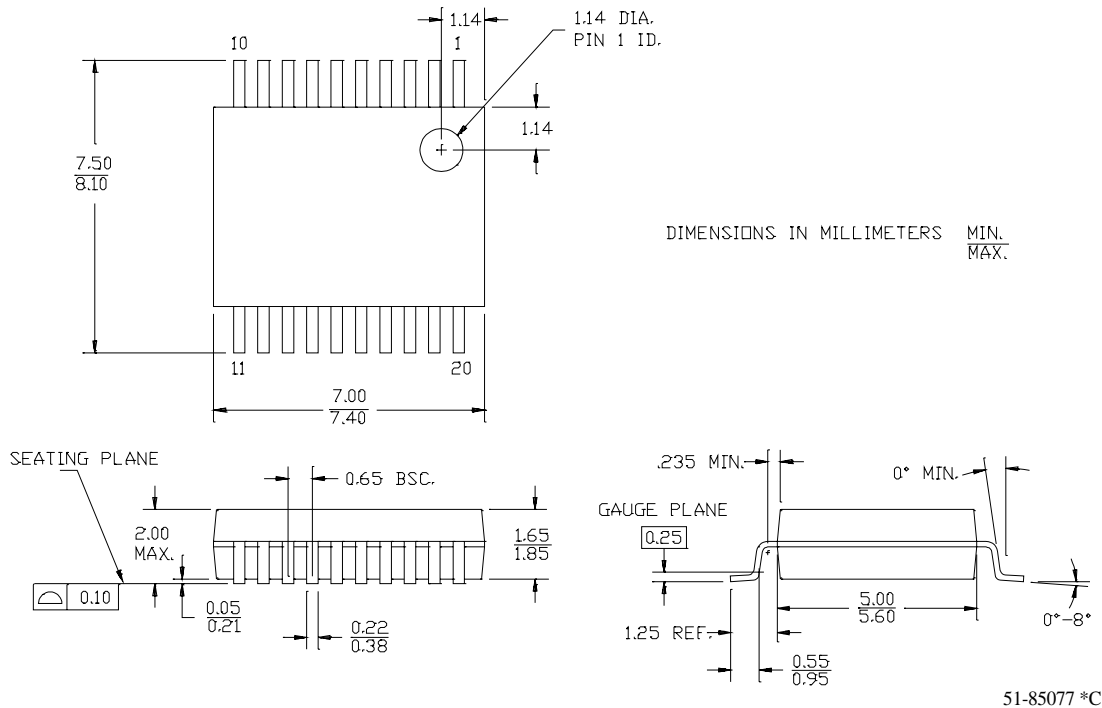

Figure 4-2. 20-Lead (210-MIL) SSOP

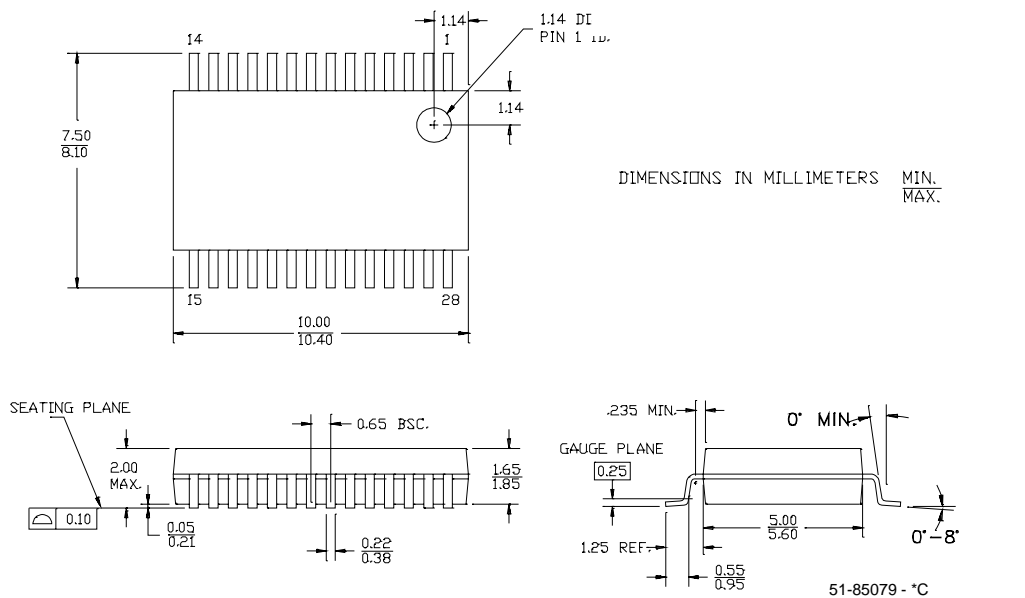
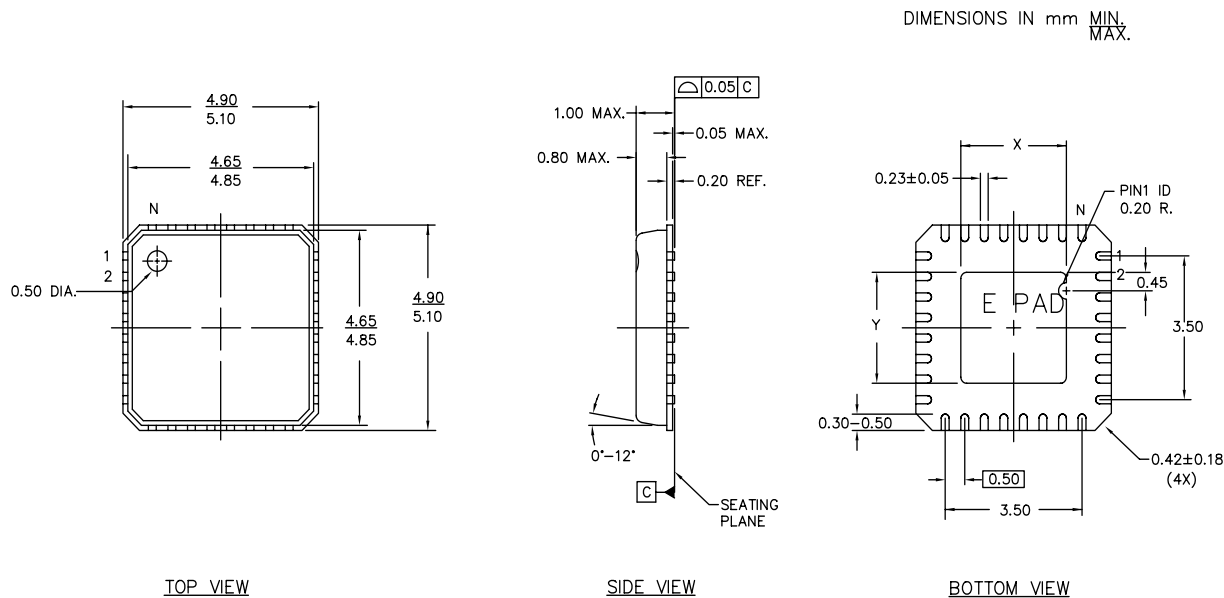

Figure 4-3. 28-Lead (210-Mil) SSOP



NOTE: E-PAD X, Y DIMENSION VARIES BY PRODUCT DUE TO DIE SIZE VARIABLE.

JEDEC # MO-220

51-85188 **

Figure 4-4. 32-Lead (5x5 mm) MLF

4.2 Thermal Impedances

Table 4-1. Thermal Impedances per Package

Package	Typical θ_{JA} *
16 SOIC	96 °C/W
20 SSOP	95 °C/W
28 SSOP	101 °C/W
32 MLF	22 °C/W

* $T_J = T_A + \text{Power} \times \theta_{JA}$

4.3 Solder Reflow Peak Temperature

Following is the minimum solder reflow peak temperature to achieve good solderability.

Table 4-2. Solder Reflow Peak Temperature

Package	Minimum Peak Temperature*	Maximum Peak Temperature
16 SOIC	220°C	260°C
20 SSOP	240°C	260°C
28 SSOP	240°C	260°C
32 MLF	220°C	260°C

*Higher temperatures may be required based on the solder melting point. Typical temperatures for solder are 220+/-5°C with Sn-Pb or 245+/-5°C with Sn-Ag-Cu paste. Refer to the solder manufacturer specifications.

5. Ordering Information



The following table lists the CY8C21x34 PSoC device's key package features and ordering codes.

CY8C21x34 PSoC Device Key Features and Ordering Information

Package	Ordering Code	Flash (Bytes)	SRAM (Bytes)	Switch Mode Pump	Temperature Range	Digital Blocks	Analog Blocks	Digital IO Pins	Analog Inputs ^a	Analog Outputs	XRES Pin
16 Pin (150-Mil) SOIC	CY8C21234-24SXI	8K	512	Yes	-40°C to +85°C	4	4	12	12 ^a	0	No
16 Pin (150-Mil) SOIC (Tape and Reel)	CY8C21234-24SXIT	8K	512	Yes	-40°C to +85°C	4	4	12	12 ^a	0	No
20 Pin (300-Mil) SSOP	CY8C21334-24PVXI	8K	512	No	-40°C to +85°C	4	4	16	16 ^a	0	Yes
20 Pin (300-Mil) SSOP (Tape and Reel)	CY8C21334-24PVXIT	8K	512	No	-40°C to +85°C	4	4	16	16 ^a	0	Yes
28 Pin (210-Mil) SSOP	CY8C21534-24PVXI	8K	512	No	-40°C to +85°C	4	4	24	24 ^a	0	Yes
28 Pin (210-Mil) SSOP (Tape and Reel)	CY8C21534-24PVXIT	8K	512	No	-40°C to +85°C	4	4	24	24 ^a	0	Yes
32 Pin (5x5) MLF ^b	CY8C21434-24LFXI	8K	512	No	-40°C to +85°C	4	4	28	28 ^a	0	Yes
32 Pin (5x5) MLF ^b (Tape and Reel)	CY8C21434-24LFXIT	8K	512	No	-40°C to +85°C	4	4	28	28 ^a	0	Yes
32 Pin (5x5) MLF ^b	CY8C21634-24LFXI	8K	512	Yes	-40°C to +85°C	4	4	26	26 ^a	0	Yes
32 Pin (5x5) MLF ^b (Tape and Reel)	CY8C21634-24LFXIT	8K	512	Yes	-40°C to +85°C	4	4	26	26 ^a	0	Yes

- a. All Digital IO Pins also connect to the common analog mux.
 b. Refer to the "32-Pin Part Pinout" on page 11 for pin differences.

5.1 Ordering Code Definitions

CY 8 C 21 xxx-24xx

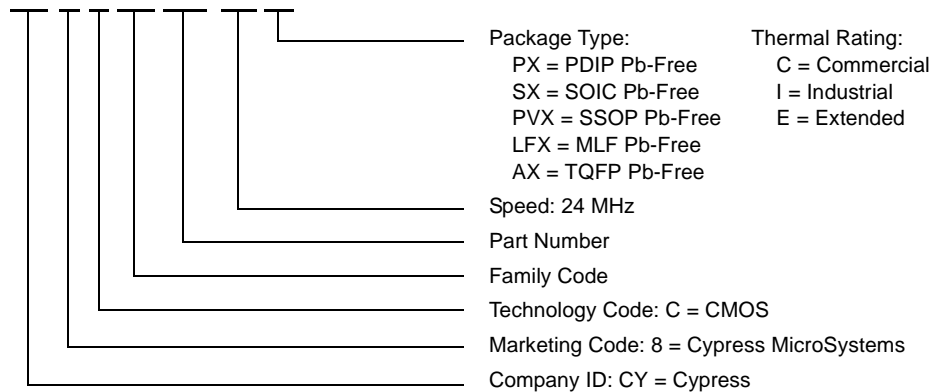

6. Sales and Service Information



To obtain information about Cypress Microsystems or PSoC sales and technical support, reference the following information or go to the section titled "Getting Started" on page 4 in this document.

Cypress Microsystems

2700 162nd Street SW
Building D
Lynnwood, WA 98037

Phone: 800.669.0557
Facsimile: 425.787.4641

Web Sites: Company Information – <http://www.cypress.com>
Sales – http://www.cypress.com/aboutus/sales_locations.cfm
Technical Support – <http://www.cypress.com/support/login.cfm>

6.1 Revision History

Document Title: CY8C21234, CY8C21334, CY8C21434, CY8C21534, and CY8C21634 PSoC Mixed-Signal Array Final Data Sheet				
Document Number: 38-12025				
Revision	ECN #	Issue Date	Origin of Change	Description of Change
**	227340	05/19/2004	HMT	New silicon and document (Revision **).
*A	235992	See ECN	SFV	Updated Overview and Electrical Spec. chapters, along with revisions to the 24-pin pinout part. Revised the register mapping tables. Added a SSOP 28-pin part.
*B	248572	See ECN	SFV	Changed title to include all part #s. Changed 28-pin SSOP from CY8C21434 to CY8C21534. Changed pin 9 on the 28-pin SSOP from SMP pin to Vss pin. Added SMP block to architecture diagram. Update Electrical Specifications. Added another 32-pin MLF part: CY8C21634.
*C	277832	See ECN	HMT	Verify data sheet standards from SFV memo. Add Analog Input Mux to applicable pin outs. Update PSoC Characteristics table. Update diagrams and specs. Final.
*D	285293	See ECN	HMT	Update 2.7V DC GPIO spec. Add Reflow Peak Temp. table.
Distribution: External/Public		Posting: None		

6.2 Copyrights and Code Protection

© Cypress Microsystems, Inc. 2004. All rights reserved. PSoC™, PSoC Designer™, and Programmable System-on-Chip™ are trademarks of Cypress Microsystems, Inc. All other trademarks or registered trademarks referenced herein are property of the respective corporations.

The information contained herein is subject to change without notice. Cypress Microsystems assumes no responsibility for the use of any circuitry other than circuitry embodied in a Cypress Microsystems product. Nor does it convey or imply any license under patent or other rights. Cypress Microsystems does not authorize its products for use as critical components in life-support systems where a malfunction or failure may reasonably be expected to result in significant injury to the user. The inclusion of Cypress Microsystems products in life-support systems application implies that the manufacturer assumes all risk of such use and in doing so indemnifies Cypress Microsystems against all charges. Cypress Microsystems products are not warranted nor intended to be used for medical, life-support, life-saving, critical control or safety applications, unless pursuant to an express written agreement with Cypress Microsystems.

Note the following details of the Flash code protection features on Cypress Microsystems devices.

Cypress Microsystems products meet the specifications contained in their particular Cypress Microsystems Data Sheets. Cypress Microsystems believes that its family of products is one of the most secure families of its kind on the market today, regardless of how they are used. There may be methods, unknown to Cypress Microsystems, that can breach the code protection features. Any of these methods, to our knowledge, would be dishonest and possibly illegal. Neither Cypress Microsystems nor any other semiconductor manufacturer can guarantee the security of their code. Code protection does not mean that we are guaranteeing the product as "unbreakable."

Cypress Microsystems is willing to work with the customer who is concerned about the integrity of their code. Code protection is constantly evolving. We at Cypress Microsystems are committed to continuously improving the code protection features of our products.