

REVISION A

DO NOT SCALE FROM THIS PRINT

NOTES:

1. **.342 STACKER HEIGHT NOT AVAILABLE AS STANDARD.**
2. Ⓢ REPRESENTS A CRITICAL DIMENSION.
3. BURR ALLOWANCE: .0015[0.038] MAX.
4. MINIMUM PUSHOUT FORCE: SIGNAL: .5 LB, GROUND: 1 LB.
5. MAX VARIANCE OF .002[0.05].
6. DIMENSION APPLIES TO CONTACTS & GROUND PLANES.
7. GROUND PLANE PRESS HEIGHT MUST BE .003[0.08] LESS THAN THE MAX HEIGHT OR .001[0.03] GREATER THAN THE MINIMUM HEIGHT OF THE TERMINAL.
8. PARTS TO BE PACKAGED IN TRAYS.

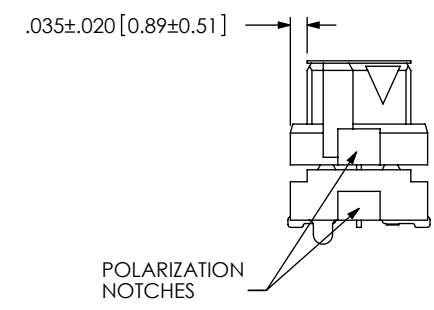
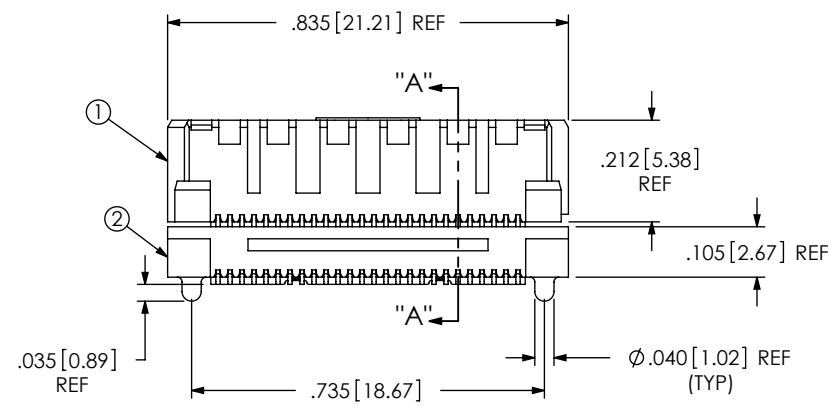
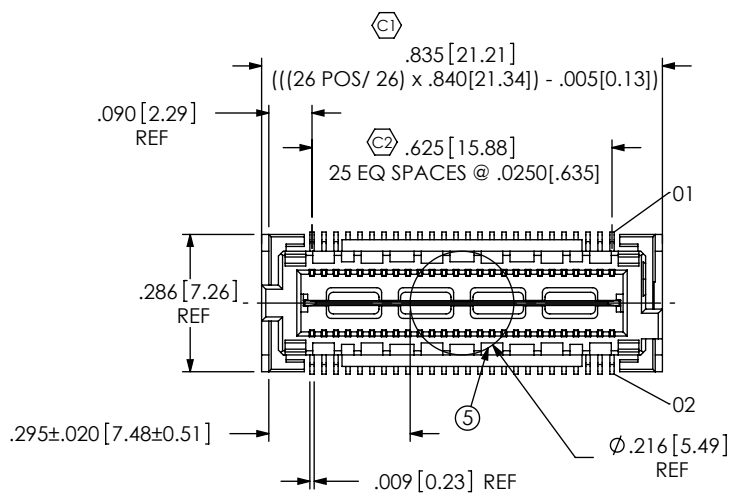
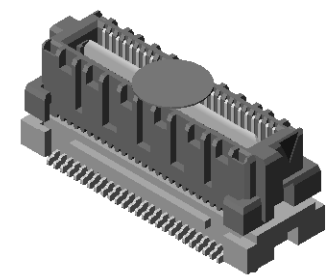

DATE: _____

COMPANY: _____

CUSTOMER SIGNATURE: _____

PRINTED NAME: _____

PHONE No: _____

FAX No: _____

ACCEPTANCE OF DRAWING: _____

ACCEPTED WITH DEVIATIONS LISTED: _____

ITEM NO.	PART NUMBER	QUANTITY	MATERIAL
1	QMSS-26-05.75-D-01	1.0000	VECTRA E130i, COLOR: BLACK
2	ASP-129634-01-B	1.0000	VECTRA E130i, COLOR: BLACK
3	ASP-129635-02-P-S	52.000	PHOS BRONZE, 521 EXTRA SPRING TEMPER
4	ASP-129636-02-P-L	1.0000	PHOS BRONZE, 510 FULL HARD TEMPER
5	K-500-300	1.0000	POLYAMIDE FILM (KAPTON)
6	TY-ASP-088	.01786	ANTI-STATIC BLACK HIPS

UNLESS OTHERWISE SPECIFIED, DIMENSIONS ARE IN INCHES. TOLERANCES ARE:

DECIMALS	ANGLES
.XX: ±.01[.3]	2°
.XXX: ±.005[.13]	
.XXXX: ±.0020[.051]	

PROPRIETARY NOTE
THIS DOCUMENT CONTAINS INFORMATION CONFIDENTIAL AND PROPRIETARY TO SAMTEC, INC. AND SHALL NOT BE REPRODUCED OR TRANSFERRED TO OTHER DOCUMENTS OR DISCLOSED TO OTHERS OR USED FOR ANY PURPOSE OTHER THAN THAT WHICH IT WAS OBTAINED WITHOUT THE EXPRESSED WRITTEN CONSENT OF SAMTEC, INC.

520 PARK EAST BLVD., NEW ALBANY, IN 47150
 PHONE: 812-944-6733 FAX: 812-948-5047
 e-Mail: info@SAMTEC.com code: 55322

DO NOT SCALE DRAWING SHEET SCALE: 2.5:1
 PLATING:
 CONTACT AREA: .000030 GOLD OVER .000050 NICKEL
 REMAINDER: .000200 REF TIN OVER .000050 NICKEL

DESCRIPTION: ELEVATED QMS ASSM
 DWG. NO. ASP-129637-01

RECOMMENDED PCB LAYOUT

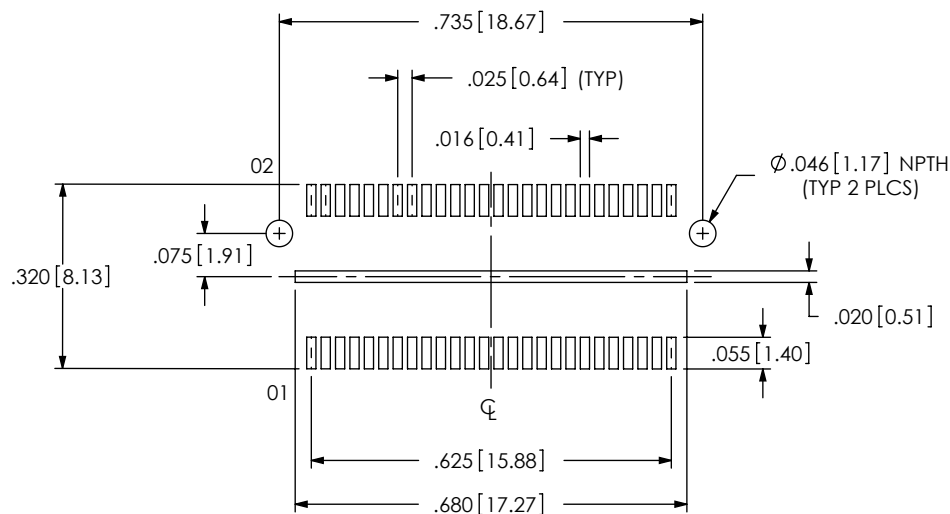

(ALL DIMENSIONS ARE SYMMETRIC ABOUT THE CENTERLINE)

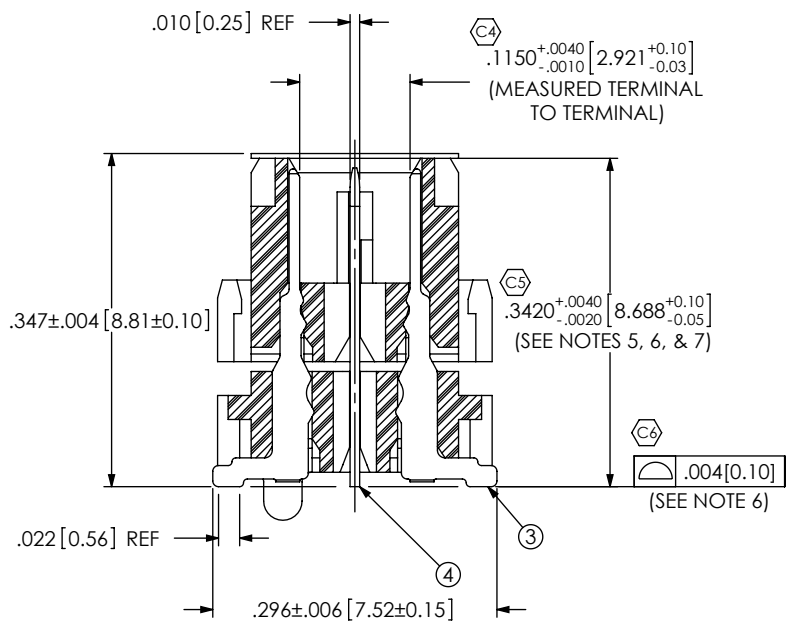

SECTION "A"-A"
SCALE 5:1

IN-PROCESS

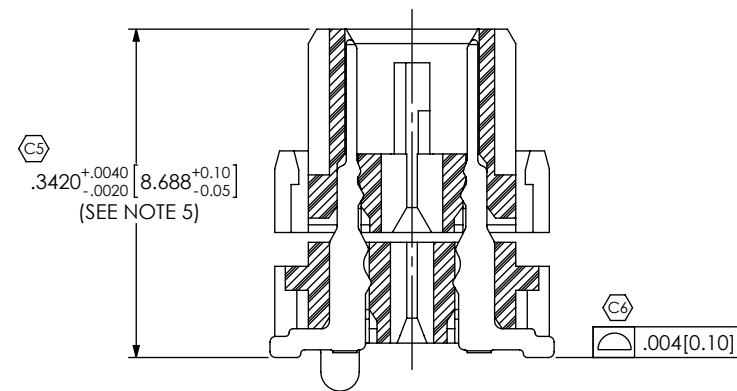

PROPRIETARY NOTE

THIS DOCUMENT CONTAINS INFORMATION CONFIDENTIAL AND PROPRIETARY TO SAMTEC, INC. AND SHALL NOT BE REPRODUCED OR TRANSFERRED TO OTHER DOCUMENTS OR DISCLOSED TO OTHERS OR USED FOR ANY PURPOSE OTHER THAN THAT WHICH IT WAS OBTAINED WITHOUT THE EXPRESSED WRITTEN CONSENT OF SAMTEC, INC.



520 PARK EAST BLVD, NEW ALBANY, IN 47150
PHONE: 812-944-6733 FAX: 812-948-5047
e-Mail: info@SAMTEC.com code: 55322

SHEET SCALE: 5:1

DESCRIPTION: ELEVATED QMS ASSM

DWG. NO. ASP-129637-01

BY: CLAY W 12/12/2006 SHEET 2 OF 2