

TA75254P

SINGLE OPERATIONAL AMPLIFIER

The TA75254P monolithic instrumentation operational amplifier combined superlative performance in low signal level applications and has low input offset voltage and bias current combined with very high levels of gain, input impedance, CMRR and SVRR.

The TA75254P is an excellent choice for a wide variety of applications including strain gauge and thermocouple bridges, high gain active filters, integrators and sample-and-hold amplifiers.

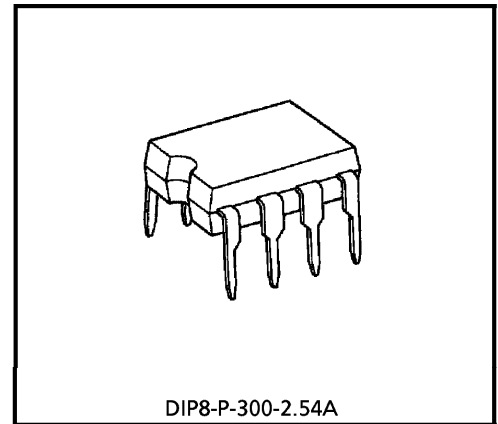

Weight : 0.5g (Typ.)

FEATURES

- Low Input Offset Voltage : 1.3mV MAX.
- Low Input Offset Voltage Drift : 1.5 μ V/ $^{\circ}$ C
- Low Input Bias Current : 30nA MAX.
- Low Input Offset Current : 10nA MAX.
- Internally Frequency Compensation
- Offset Nulling Capability
- Supply Voltage : $\pm 3 \sim \pm 18$ V

PIN CONNECTION (TOP VIEW)

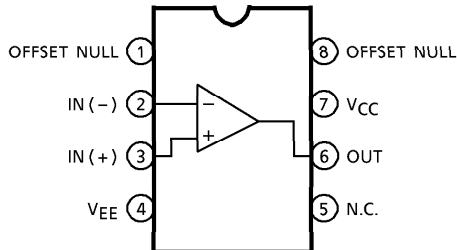

EQUIVALENT CIRCUIT

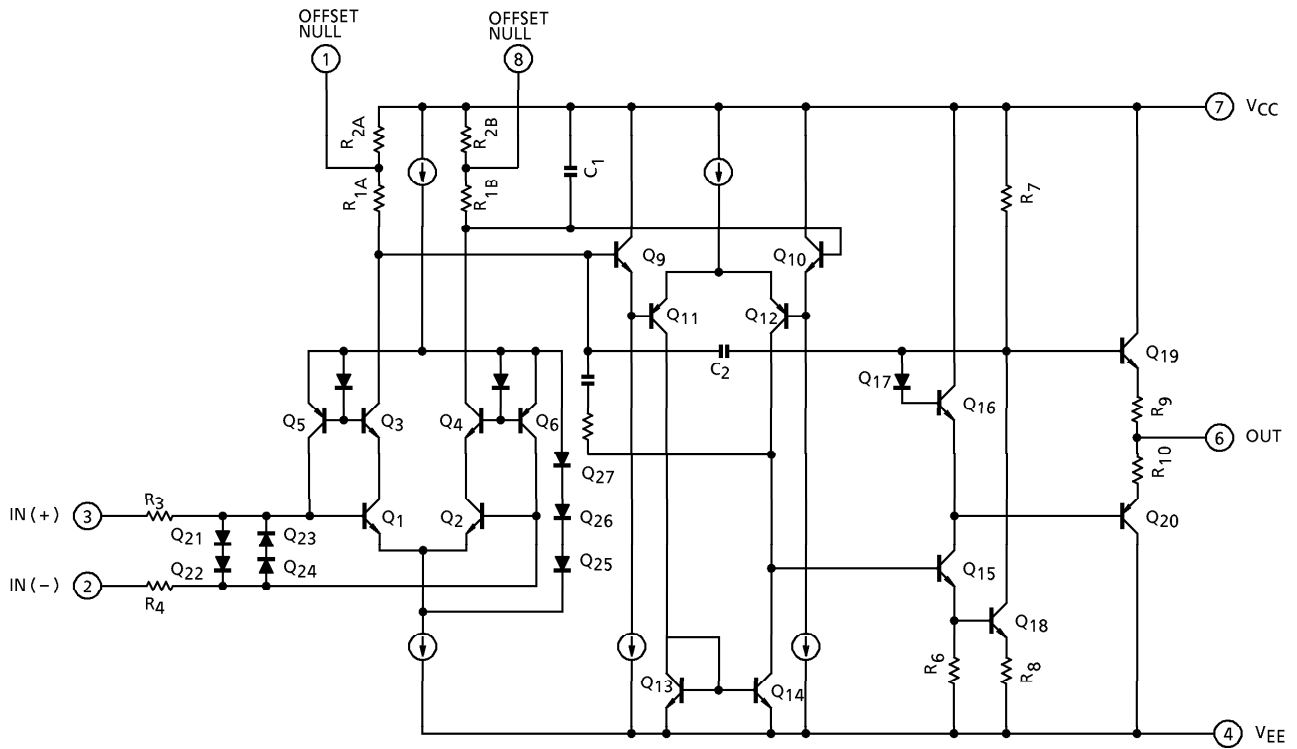

MAXIMUM RATINGS (Ta = 25°C)

CHARACTERISTIC	SYMBOL	RATING	UNIT
Supply Voltage	V _{CC} , V _{EE}	18, -18	V
Differential Voltage	DV _{IN}	±12	V
Input Voltage	V _{IN}	V _{CC} ~V _{EE}	V
Power Dissipation	P _D	500	mW
Operating Temperature	T _{opr}	-40~85	°C
Storage Temperature	T _{stg}	-55~125	°C

ELECTRICAL CHARACTERISTICS (V_{CC} = 15V, V_{EE} = -15V, Ta = 25°C)

CHARACTERISTIC	SYMBOL	TEST CIR-CUIT	TEST CONDITION	MIN.	TYP.	MAX.	UNIT
Input Offset Voltage	V _{IO}	—	R _g ≤ 10kΩ	—	0.3	1.3	mV
Input Offset Current	I _{IO}	—	—	—	0.3	10	nA
Input Bias Current	I _I	—	—	-30	—	30	nA
Common Mode Input Voltage	CMV _{IN}	—	—	±13	±14	—	V
Maximum Output Voltage	V _{OM}	—	R _L = 10kΩ	±12	±13	—	V
	V _{OMR}	—	R _L = 2kΩ	±11.5	±12.8	—	
Source Current	I _{source}	—	—	10	25	—	mA
Sink Current	I _{sink}	—	—	10	25	—	mA
Open Loop Voltage Gain	G _V	—	R _L ≥ 2kΩ	86	110	—	dB
Common Mode Input Signal Rejection Ratio	CMRR	—	R _g ≤ 10kΩ	70	110	—	dB
Supply Voltage Rejection Ratio	SVRR	—	R _g = 10kΩ	80	110	—	dB
Slew Rate	SR	—	—	—	0.2	—	V / μs
Unity Gain Cross Frequency	f _T	—	—	—	0.5	—	MHz
Supply Current	I _{CC} , I _{EE}	—	—	—	3.2	6.0	mA
Input Noise Voltage	V _{NI}	—	—	—	1	—	μV _{rms}
Input Resistance	R _{IN}	—	—	—	50	—	MΩ
TC Of Input Offset Voltage (Note 1)	ΔV _{IO} / ΔT	—	R _g ≤ 10kΩ, unnull	—	1.2	4.5	μV / °C
		—	R _g ≤ 10kΩ, null, R _p = 20kΩ	—	0.4	1.5	
TC Of Input Bias Current	ΔI _I / ΔT	—	—	—	18	—	PA / °C
TC Of Input Offset Current	ΔI _{IO} / ΔT	—	—	—	12	—	PA / °C

(Note 1) Sample Tested (LTPD10)

CHARACTERISTICS

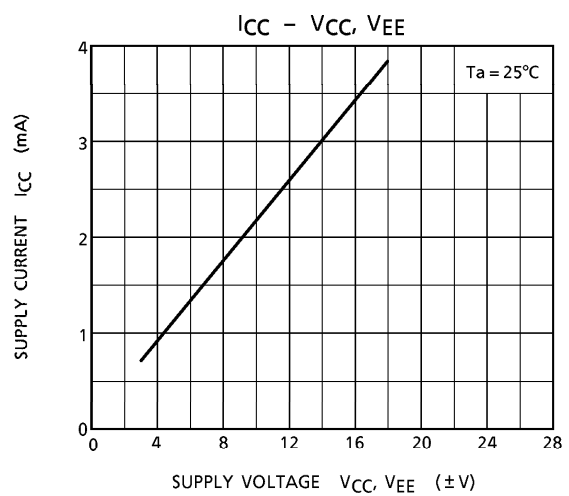
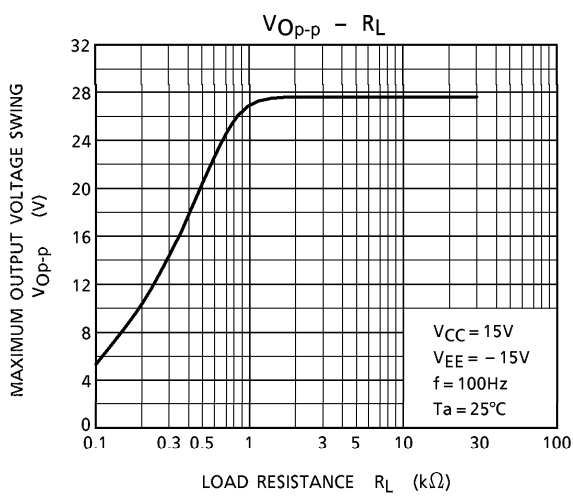
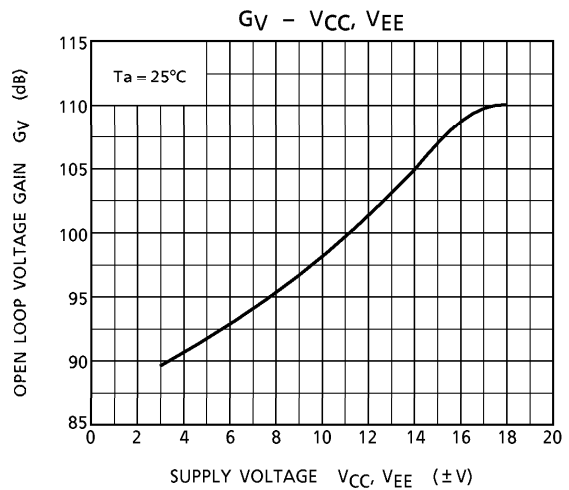
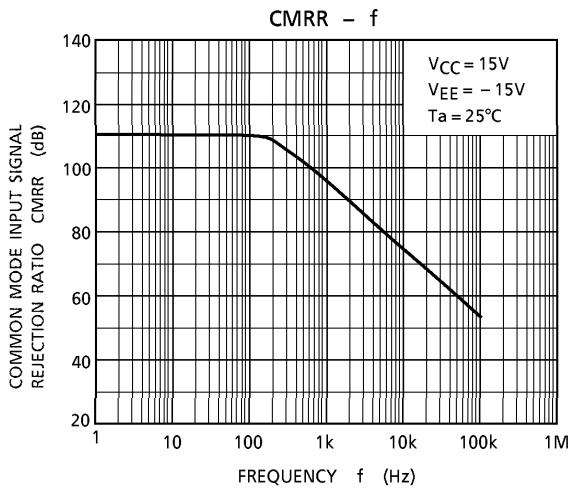
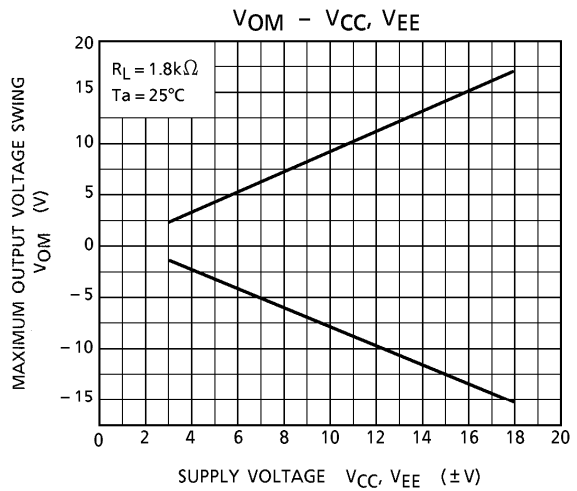
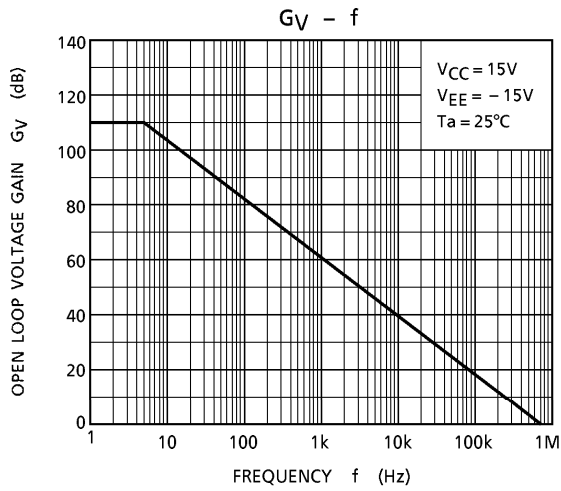

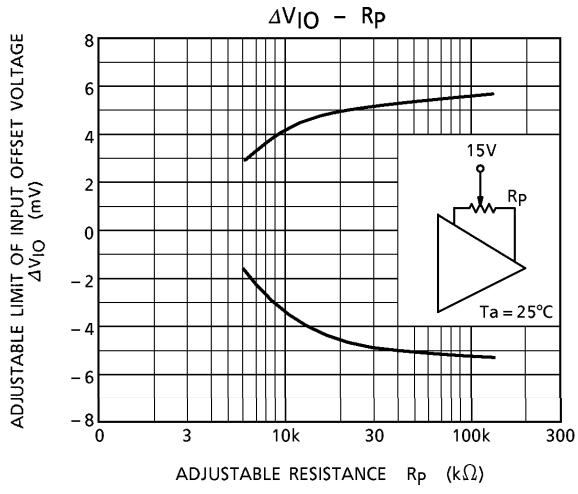

PACKAGE DIMENSIONS
DIP8-P-300-2.54A

Unit : mm

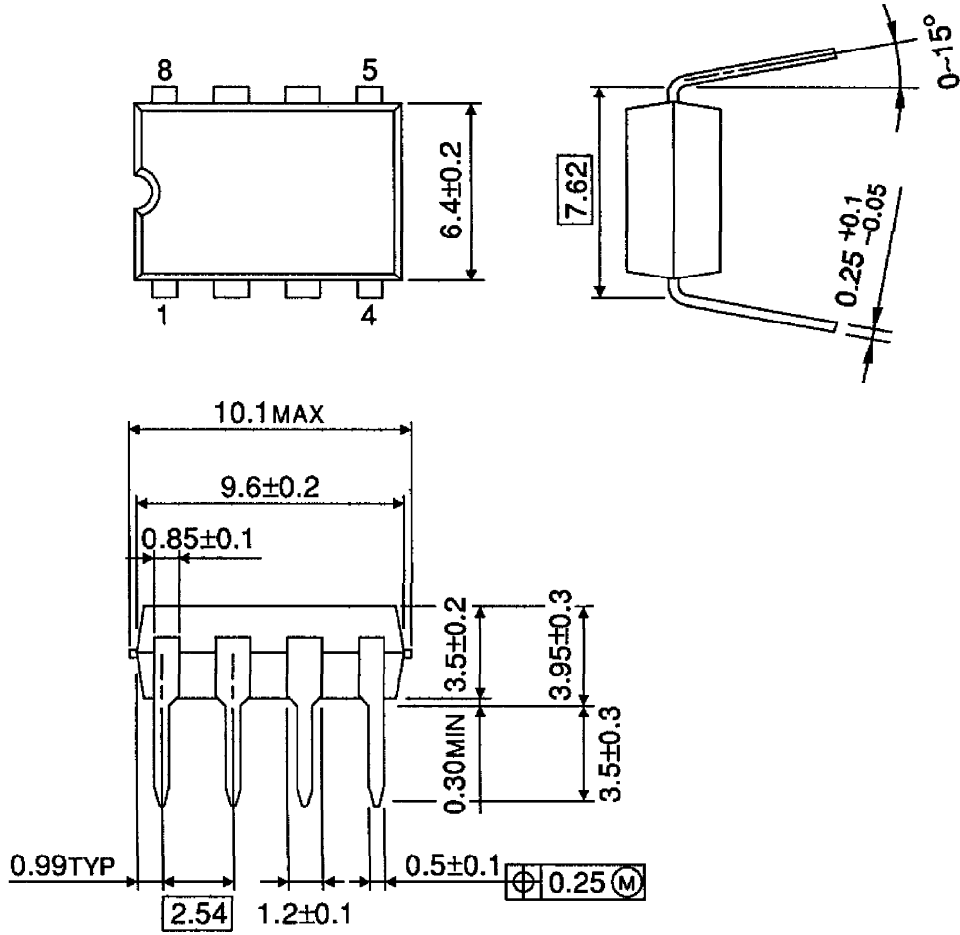

Weight : 0.5g (Typ.)

RESTRICTIONS ON PRODUCT USE

000707EBA

- TOSHIBA is continually working to improve the quality and reliability of its products. Nevertheless, semiconductor devices in general can malfunction or fail due to their inherent electrical sensitivity and vulnerability to physical stress. It is the responsibility of the buyer, when utilizing TOSHIBA products, to comply with the standards of safety in making a safe design for the entire system, and to avoid situations in which a malfunction or failure of such TOSHIBA products could cause loss of human life, bodily injury or damage to property. In developing your designs, please ensure that TOSHIBA products are used within specified operating ranges as set forth in the most recent TOSHIBA products specifications. Also, please keep in mind the precautions and conditions set forth in the "Handling Guide for Semiconductor Devices," or "TOSHIBA Semiconductor Reliability Handbook" etc..
- The TOSHIBA products listed in this document are intended for usage in general electronics applications (computer, personal equipment, office equipment, measuring equipment, industrial robotics, domestic appliances, etc.). These TOSHIBA products are neither intended nor warranted for usage in equipment that requires extraordinarily high quality and/or reliability or a malfunction or failure of which may cause loss of human life or bodily injury ("Unintended Usage"). Unintended Usage include atomic energy control instruments, airplane or spaceship instruments, transportation instruments, traffic signal instruments, combustion control instruments, medical instruments, all types of safety devices, etc.. Unintended Usage of TOSHIBA products listed in this document shall be made at the customer's own risk.
- The products described in this document are subject to the foreign exchange and foreign trade laws.
- The information contained herein is presented only as a guide for the applications of our products. No responsibility is assumed by TOSHIBA CORPORATION for any infringements of intellectual property or other rights of the third parties which may result from its use. No license is granted by implication or otherwise under any intellectual property or other rights of TOSHIBA CORPORATION or others.
- The information contained herein is subject to change without notice.