

**features**

- Metal glaze resistors (RuO<sub>2</sub>) provide lifetime stability
- Free from short circuit, unexpected solder melting and terminal disconnection due to the high temperature solder used to connect terminals
- Capable of reducing the numbers of parts and part insertions
- Custom orders are available
- Marking: Black body color
- Products with lead-free termination meet EU-RoHS requirements. EU-RoHS regulation is not intended for Pb-glass contained in electrode, resistor element and glass

**dimensions and construction**

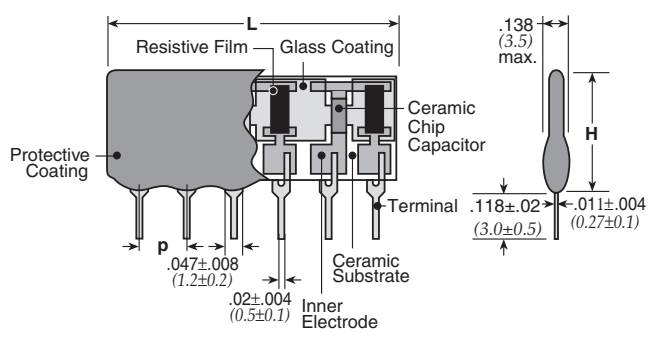

Type	Dimensions inches (mm)			
	Number of Pins	L	H	p
CRA □	5 – 90	.100xP+.024 (2.54xP+0.6)	.256 (6.5)	.100 (2.54)
CRB □	5 – 10			
CRC □	5 – 13			
CRD □	5 – 13			
CRE □	6 – 14			
CRF □	5 – 13			

P= Number of pins

**ordering information**

<b>CR</b>	<b>E</b>	<b>6</b>	<b>01</b>	<b>D</b>
Product Code	Circuit Symbol	Number of Cells	KOA Reference Number	Terminal Surface Material
	A B C D E F M	4 – 8 (CRA) 3 – 8 (CRB) 2 – 6 (CRC, CRD, CRE, CRF) Nil (CRM)		D: SnAgCu Nil: Sn/Pb

**ratings**

Parameter	Resistor	Capacitor
Max. Operating Voltage	50V	
Constant Range	10Ω – 1MΩ	10pF – 0.1μF
T.C.	±200x10 <sup>-6</sup> /K	CH, B, R, F
Tolerance	±5% (J)	±5% (J) ±10% (K) ±20% (M) -20% – +80% (Z)
Operating Temp. Range	-25°C – +85°C	
Storage Temp. Range	-55°C – +125°C	

**maximum wattage/package**

	Number of Pins				
	5	6	7	8	9
mW/Package	500	625	750	875	1000

	Number of Pins				
	10	11	12	13	14
mW/Package	1050	1150	1250	1350	1450

Specifications given herein may be changed at any time without prior notice. Please confirm technical specifications before you order and/or use. 12/28/10

## circuit schematics

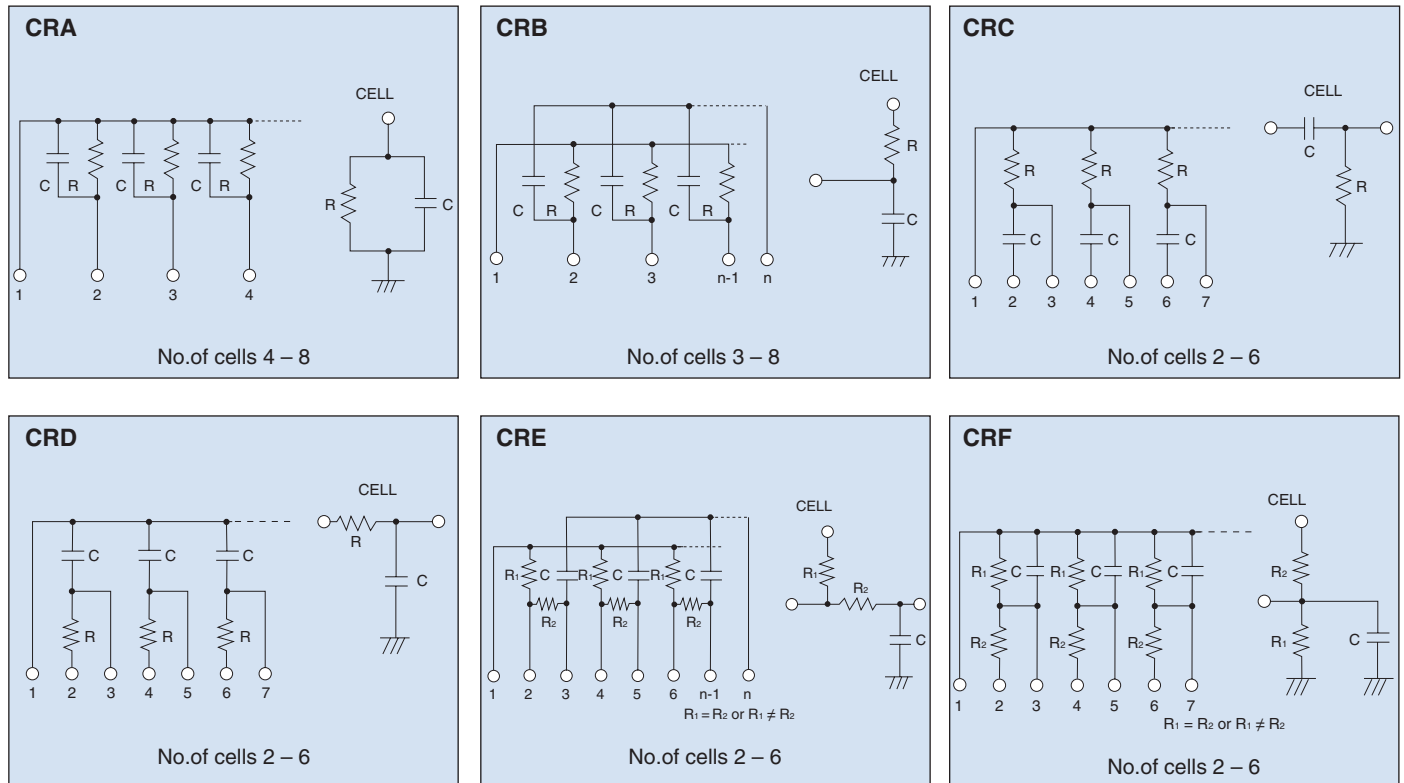

When ordering the CR series, please indicate the following items shown below:

For circuit code A – F, please indicate the following items:

Resistance  
Capacitance  
Operating voltage  
Capacitance tolerance  
T.C.

For circuit code M, please add the following items:

Circuit schematics  
Pin layout  
Dimensions  
Conditions for use  
Resistor (Power rating, Tolerance, T.C.R.)