

1 Stereo Input and 1 Stereo Output Volume, Tone, Balance, Loudness Function

FEATURES

- Operation range : 2.7V~6.5V
- 2 independent speaker controls for balance
- Tone controls (treble and bass)
- Loudness and independent mute function
- Volume control in 1.25 dB/step
- I²C interface
- Components less and good PSRR
- Housed in SOP20, SSOP20 package

APPLICATIONS

- Portable audio device
- Hi-Fi audio system
- Cross-reference:
TDA7315

DESCRIPTION

The MS6715 is a 1 stereo inputs/2-channel outputs digital control audio processor for the low voltage operation. Volume, tone (bass and treble), and balance (left/right) processor are incorporated into a single chip. The MS6715 also has the loudness function. These functions can be built a Hi-Fi audio system easily. All functions are programmable via the serial I²C bus. The default states of the chip as the power is on are: the volume is -78.75dB, the stereo 4 is selected, all the speakers are mute and the gains of the bass and the treble are 0dB.

BLOCK DIAGRAM

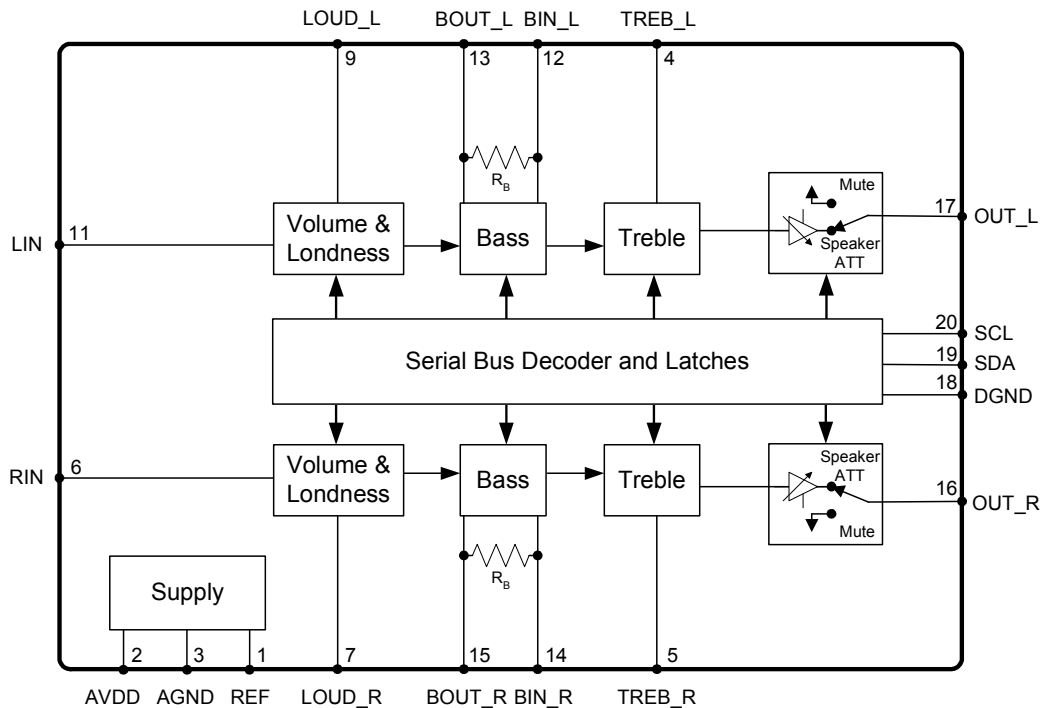

PIN CONFIGURATION

Symbol	Pin	Description	
REF	1	Analog Reference Voltage (1/2VDD)	<p style="text-align: center;">MS6715</p> <p style="text-align: center;">SOP20 / SSOP20</p>
VDD	2	Supply Input Voltage	
AGND	3	Analog Ground	
TREB_L	4	Left Channel Input for Treble Controller	
TREB_R	5	Right Channel Input for Treble Controller	
RIN	6	Right Channel Input	
LOUD_R	7	Right Channel Loudness Input	
NC	8	No Connected	
LOUD_L	9	Left Channel Loudness Input	
NC	10	No Connected	
LIN	11	Left Channel Input	
BIN_L	12	Left Bass Controller Input Channel	
BOUT_L	13	Left Bass Controller Output Channel	
BIN_R	14	Right Bass Controller Input Channel	
BOUT_R	15	Right Bass Controller Output Channel	
OUT_R	16	Right Speaker Output	
OUT_L	17	Left Speaker Output	
DGND	18	Digital Ground	
SDA	19	I ² C Data Input	
SCL	20	I ² C Clock Input	

ORDERING INFORMATION

Package	Part number	Packaging Marking	Transport Media
20-Pin SOP (lead free)	MS6715GTR	MS6715G	1k Units Tape and Reel
20-Pin SOP (lead free)	MS6715GU	MS6715G	36 Units Tube
20-Pin SSOP (lead free)	MS6715SSGTR	MS6715G	2.5k Units Tape and Reel
20-Pin SSOP (lead free)	MS6715SSGU	MS6715G	56 Units Tube

ABSOLUTE MAXIMUM RATINGS

Symbol	Parameter	Rating	Unit
VDD	Supply Voltage	6.5	V
V _{ESD}	Electrostatic Handling	-3000 to 3000	V
T _{STG}	Storage Temperature Range	-65 to 150	°C
T _A	Operating Ambient Temperature Range	-40 to 85	°C
T _J	Maximum Junction Temperature	150	°C
T _S	Soldering Temperature, 10 seconds	260	°C
R _{THJA}	Thermal Resistance from Junction to Ambient in Free Air	210 210	°C/W
	SOP20 SSOP20		

OPERATING RATINGS

Symbol	Parameter	Min	Typ	Max	Unit
V _{DD}	Supply Voltage	2.7	-	6.5	V

5V ELECTRICAL CHARACTERISTICS

(T_a=25°C, All stages 0dB, f=1kHz, C_{REF}=22uF, refer to the application circuit; unless otherwise specified)

Symbol	Parameter	Conditions	Min	Typ	Max	Unit
Supply						
I _Q	Quiescent Current	V _{IN} =0V	-	12.2	12.5	mA
PSRR	Power Supply Rejection Ratio	C _{REF} = 22uF, f = 100Hz	55	60	-	dB
Input						
R _{IN}	Input Resistance		35	50	70	kΩ
LOUD	Loudness	C _{Loud} =100nF, f=20Hz Volume=-40dB	19	20	-	dB
Volume control						
CR _{VOL}	Volume Control Range	Attenuation	-78.75	-	0	dB
RES _{VOL}	Volume Step Resolution		-	1.25	-	dB
ERR _{VOL}	Volume Setting Error	A _v = 0 to -40dB	-0.5	0	1	dB
		A _v = -40 to -60dB	-1	0	5	dB
Speaker Attenuators						
CR _{SPK}	Speaker Control Range	Attenuation	-37.5	-	0	dB
RES _{SPK}	Speaker Step Resolution		-	1.25	-	dB
ERR _{SPK}	Speaker Setting Error		-0.2	0	0.1	dB
MUTE	Output Mute Attenuation		-	-65	-60	dB
Bass Control						
CR _{BAS}	Bass Control Range	Boost/Cut	-14	-	14	dB
RES _{BAS}	Bass Step Resolution		-	2	-	dB
ERR _{BAS}	Speaker Setting Error	f=100Hz	-0.3	0	0.1	dB
R _B	Internal Feedback Resistance		34	44	58	kΩ
Treble Control						
CR _{BAS}	Treble Control Range	Boost/Cut	-14	-	14	dB
RES _{BAS}	Treble Step Resolution		-	2	-	dB
ERR _{BAS}	Treble Setting Error	f=20kHz	-0.3	0	0.1	dB
General						
VO _{MAX}	Maximum Output Voltage Swing	(THD+N)/S <0.3%	-	4.5	-	V _{pp}
THD+N	Total Harmonic Distortion Plus Noise	V _{OUT} =2V _{pp}	-	-75	-	dB
			-	0.0177	-	%
S/N	Signal-to-Noise Ratio	V _{OUT} =4V _{pp}	-	97	-	dB
CS	Channel Separation Left/Right		93	97	-	dB
Bus Input						
V _{IH}	Bus High Input Level		2	-	-	V
V _{IL}	Bus Low Input Level		-	-	0.8	V

Notes: Bass and Treble response see to curve. The center frequency and quality of the response behavior can be chosen by the external.

2.7V ELECTRICAL CHARACTERISTICS

($T_a=25^\circ\text{C}$, All stages 0dB, $f=1\text{kHz}$, $C_{\text{REF}}=22\mu\text{F}$, refer to the application circuit; unless otherwise specified)

Symbol	Parameter	Conditions	Min	Typ	Max	Unit
Supply						
I_Q	Quiescent Current	$V_{\text{IN}}=0\text{V}$	-	8.7	9	mA
PSRR	Power Supply Rejection Ratio	$C_{\text{REF}}=22\mu\text{F}$, $f=100\text{Hz}$	53	58	-	dB
General						
$V_{\text{O}_{\text{MAX}}}$	Maximum Output Voltage Swing	$(\text{THD}+\text{N})/\text{S} < 0.3\%$	-	2.5	-	V _{pp}
THD+N	Total Harmonic Distortion Plus Noise	$V_{\text{OUT}}=2\text{V}_{\text{pp}}$	-	-50	-	dB
			-	0.3	-	%
S/N	Signal-to-Noise Ratio	$V_{\text{OUT}}=2.5\text{V}_{\text{pp}}$	90	94	-	dB
CS	Channel Separation Left/Right		90	94	-	dB

TYPICAL PERFORMANCE CHARACTERISTICS

($T_a=25^\circ\text{C}$, All stages 0dB, $f=1\text{kHz}$, $C_{\text{REF}}=22\mu\text{F}$, refer to the application circuit; unless otherwise specified)

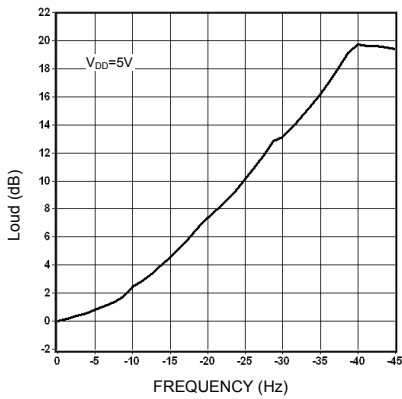

Loudness vs. Volume

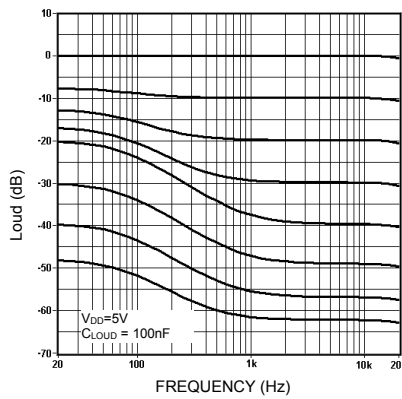

Loudness vs. Frequency vs. Volume

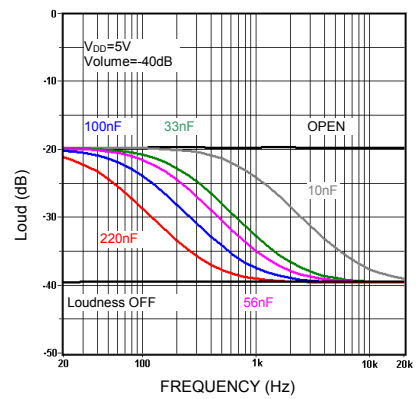

Loudness vs. External Capacitors

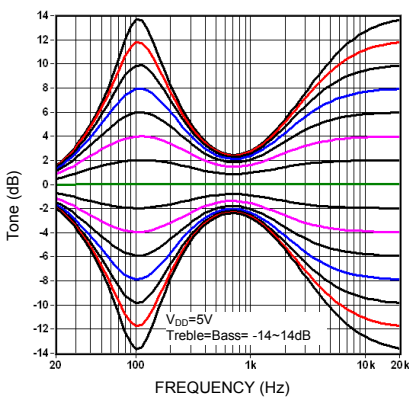

Typical Tone Response

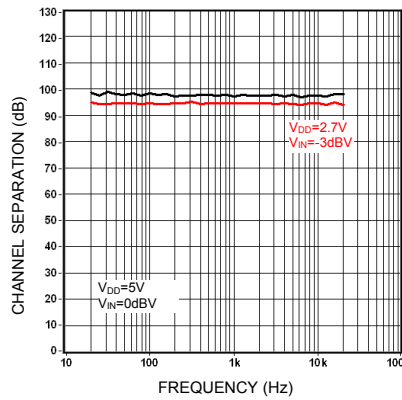

Channel Separation vs. Frequency

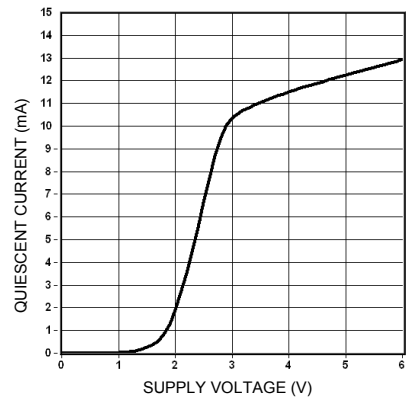

Quiescent Current vs. Supply Voltage

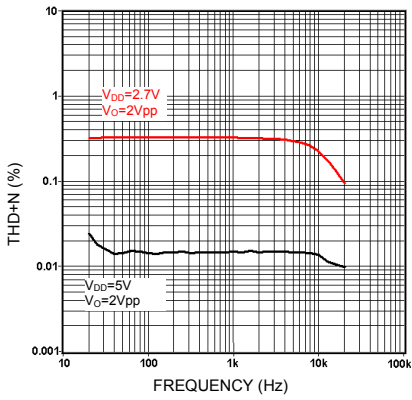

THD+N vs. Frequency

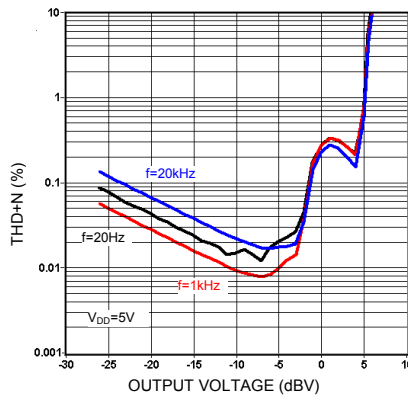

THD+N vs. Output Voltage

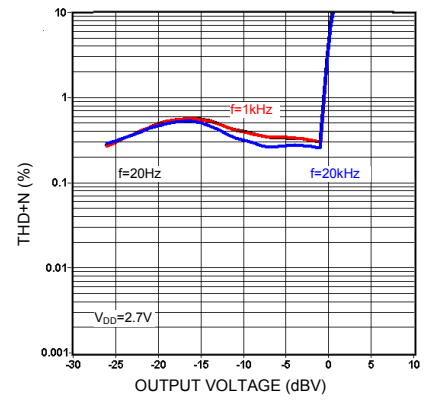

THD+N vs. Output Voltage

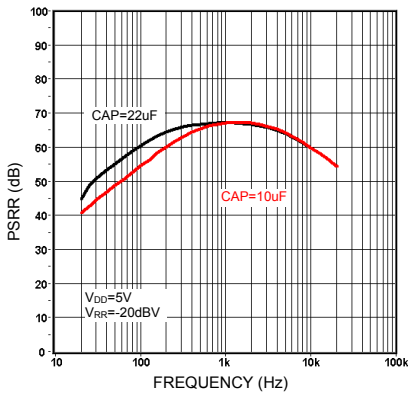

PSRR vs. Frequency

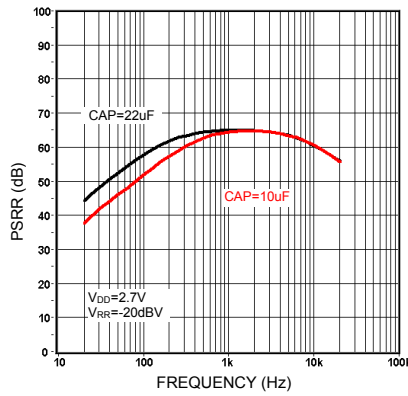

PSRR vs. Frequency

I²C BUS DESCRIPTION

Start and Stop Conditions

A start condition is activated when the SCL is set to HIGH and SDA shifts from HIGH to LOW state. The stop condition is activated when SCL is set to HIGH and SDA shifts from LOW to HIGH state. Please refer to the timing diagram below.

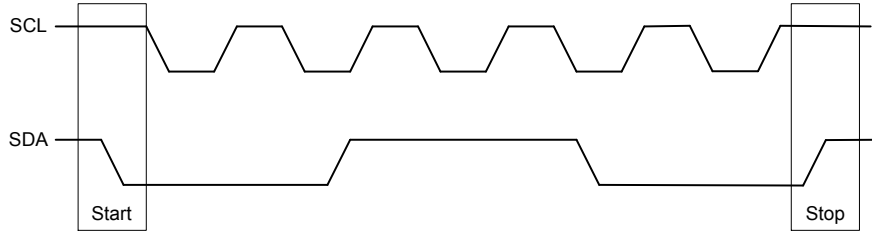

SCL: Serial Clock Line, SDA: Serial Data Line

Data Validity

A data on the SDA line is considered valid and stable only when the SCL signal is in HIGH state. The HIGH and LOW states of the SDA line can only change when the SCL signal is LOW. Please refer to the figure below.

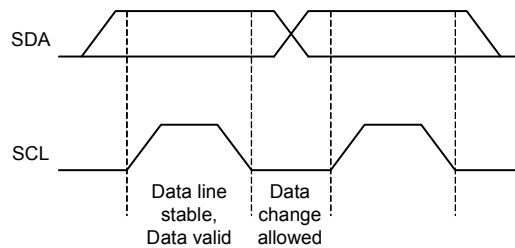

Byte Format

Every byte transmitted to the SDA line consists of 8 bits. Each byte must be followed by an acknowledge bit. The MSB is transmitted first.

Acknowledge

During the Acknowledge clock pulse, the master (up) put a resistive HIGH level on the SDA line. The peripheral (audio processor) that acknowledges has to pull-down (LOW) the SDA line during the Acknowledge clock pulse so that the SDA line is in a stable LOW state during this clock pulse. Please refer to the diagram below.

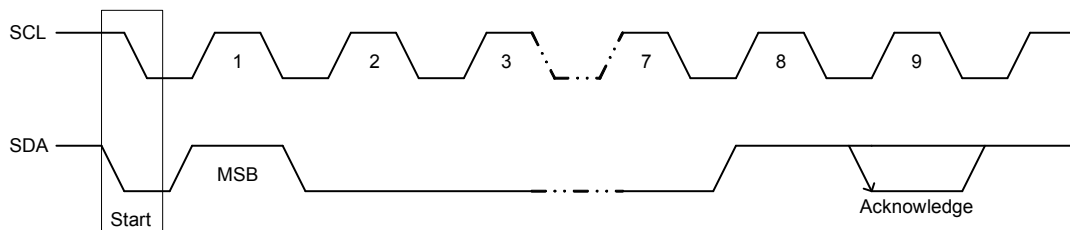

The audio processor that has been addressed has to generate an Acknowledge after receiving each byte, otherwise, the SDA line will remain at the HIGH level during the ninth (9th) clock pulse. In this case, the master transmitter can generate the STOP information in order to abort the transfer.

Timing of SDA and SCL Bus Lines

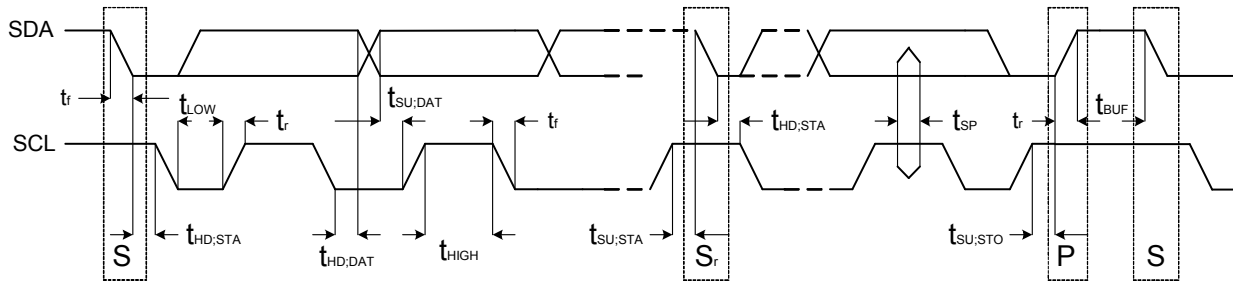

Standard Mode

Symbol	Parameter	Min	Max	Unit
f_{SCL}	SCL clock frequency	0	100	kHz
$t_{HD:STA}$	Hold time (repeated) START condition. After this period, the first clock pulse is generated	4.0	-	us
t_{LOW}	LOW period of the SCL clock	4.7	-	us
t_{HIGH}	HIGH period of the SCL clock	4.0	-	us
$t_{SU:STA}$	Set-up time for a repeated START condition	4.7	-	us
$t_{HD:DAT}$	Data hold time: For I ² C-bus devices	0	3.45	us
$t_{SU:DAT}$	Data-set-up time	250	-	ns
t_r	Rise time of both SDA and SCL signals	-	1000	ns
t_f	Fall time of both SDA and SCL signals	-	300	ns
$t_{SU:STO}$	Set-up time for STOP condition	4.0	-	us
t_{BUF}	Bus free time between a STOP and START condition	4.7	-	us
C_b	Capacitive load for each bus line	-	400	pF
V_{nL}	Noise margin at the LOW level for each connected device (including hysteresis)	$0.1V_{DD}$	-	V
V_{nH}	Noise margin at the HIGH level for each connected device (including hysteresis)	$0.2V_{DD}$	-	V

BUS INTERFACE

Data are transmitted to and from the MCU to the MS6715 via the SDA and SCL. The SDA and SCL make up the BUS interface. It should be noted that pull-up resistors must be connected to the positive supply voltage.

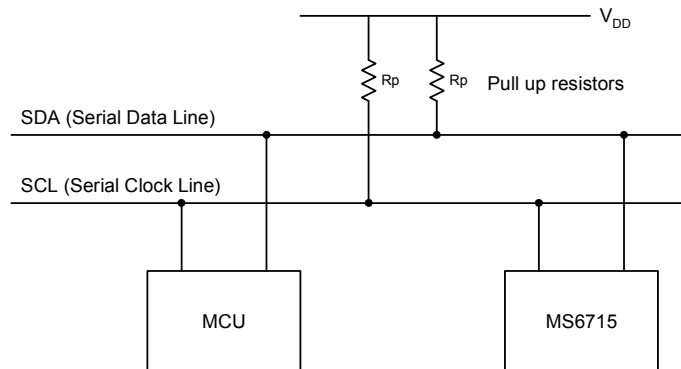

Interface Protocol

The format consists of the following

- A START condition
- A chip address byte including the MS6715 address. (7bits)
- The 8th bit of the byte must be “0”.(write=0, read=1)
- MS6715 must always acknowledge the end of each transmitted byte.
- A data sequence (N-bytes + Acknowledge)
- A STOP condition

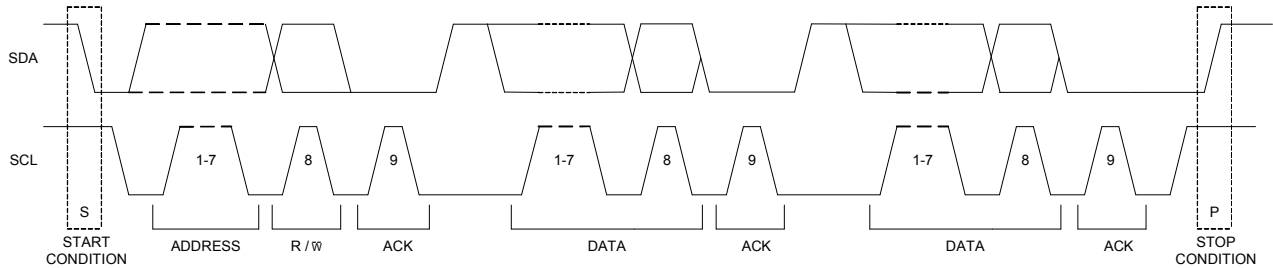

Address Code

The chip address of the MS6715 is 88H.

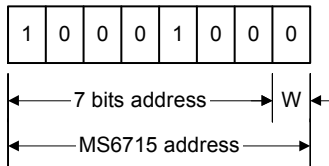

Data Bytes Description

The default states of the chip as the power is on are: the volume is -78.75dB, the stereo 4 is selected, all the speakers are mute and the gains of the bass and the treble are 0dB.

MSB		LSB						Function
0	0	B2	B1	B0	A2	A1	A0	Volume Control
1	0	0	B1	B0	A2	A1	A0	Speaker ATT L
1	0	1	B1	B0	A2	A1	A0	Speaker ATT R
0	1	0	*	*	L	*	*	Loudness Control
0	1	1	0	C3	C2	C1	C0	Bass Control
0	1	1	1	C3	C2	C1	C0	Treble Control

Where Ax = 1.25dB steps; Bx = 10dB steps; Cx = 2dB steps; * = No effect

Volume

MSB					LSB			Function
0	0	B2	B1	B0	A2	A1	A0	Volume 1.25 dB steps
					0	0	0	0
					0	0	1	-1.25
					0	1	0	-2.5
					0	1	1	-3.75
					1	0	0	-5
					1	0	1	-6.25
					1	1	0	-7.5
					1	1	1	-8.75
0	0	B2	B1	B0	A2	A1	A0	Volume 10dB steps
		0	0	0				0
		0	0	1				-10
		0	1	0				-20
		0	1	1				-30
		1	0	0				-40
		1	0	1				-50
		1	1	0				-60
		1	1	1				-70

The default volume is -78.75dB.

Speaker Attenuator

MSB					LSB			Function (dB)
1	0	0	B1	B0	A2	A1	A0	Speaker ATT L
1	0	1	B1	B0	A2	A1	A0	Speaker ATT R
					0	0	0	0
					0	0	1	-1.25
					0	1	0	-2.5
					0	1	1	-3.75
					1	0	0	-5
					1	0	1	-6.25
					1	1	0	-7.5
					1	1	1	-8.75
			0	0				0
			0	1				-10
			1	0				-20
			1	1				-30
			1	1	1	1	1	Mute

The default state is mute.

Loudness

MSB				LSB				Function
0	1	0	X	X	L	X	X	Loudness
					0			Loudness ON
					1			Loudness OFF

The default state is loudness off.

X: don't care.

Bass and Treble

MSB				LSB				Function (dB)
0	1	1	0	C3	C2	C1	C0	Bass
0	1	1	1	C3	C2	C1	C0	Treble
				0	0	0	0	-14
				0	0	0	1	-12
				0	0	1	0	-10
				0	0	1	1	-8
				0	1	0	0	-6
				0	1	0	1	-4
				0	1	1	0	-2
				0	1	1	1	0
				1	0	0	0	0
				1	0	0	1	2
				1	0	1	0	4
				1	0	1	1	6
				1	1	0	0	8
				1	1	0	1	10
				1	1	1	0	12
				1	1	1	1	14

The default state is bass 0dB and treble 0dB.

Examples

Set Volume at -37.5dB.

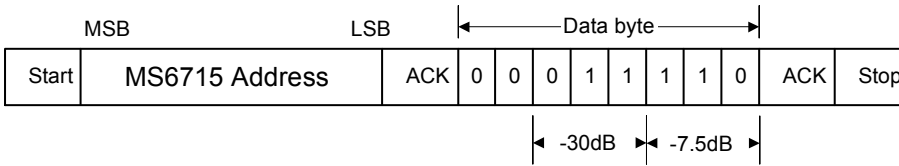

Set Speaker Right at -30dB.

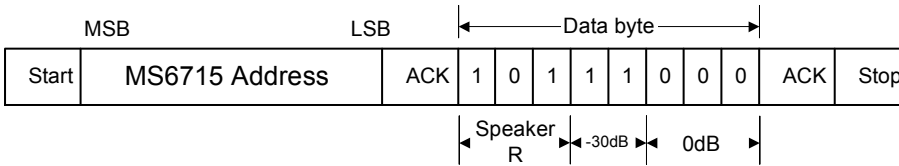

Set Speaker Left in mute-on.

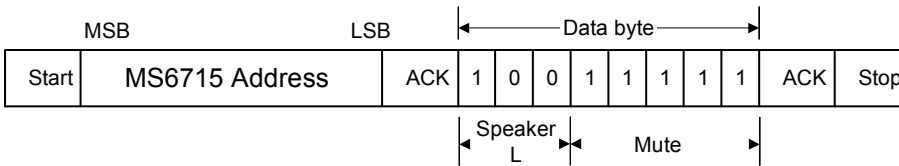

Set Loudness in turn-on.

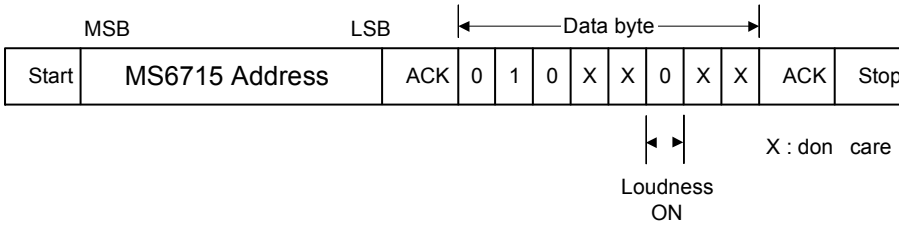

Set Treble at -10dB.

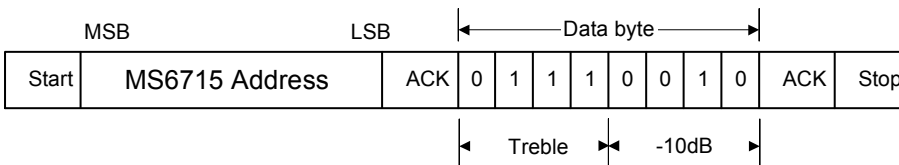

APPLICATION INFORMATION

Basic Application Example

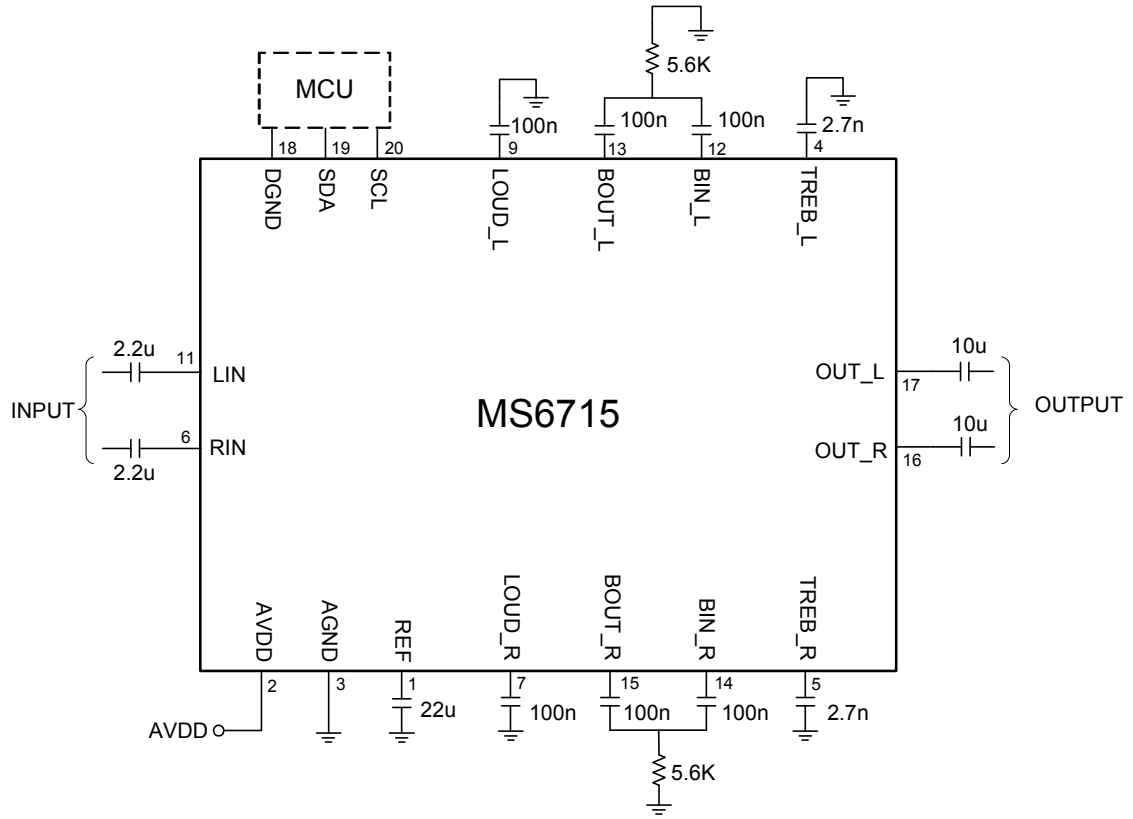

EXTERNAL DIMENSIONS

SSOP20

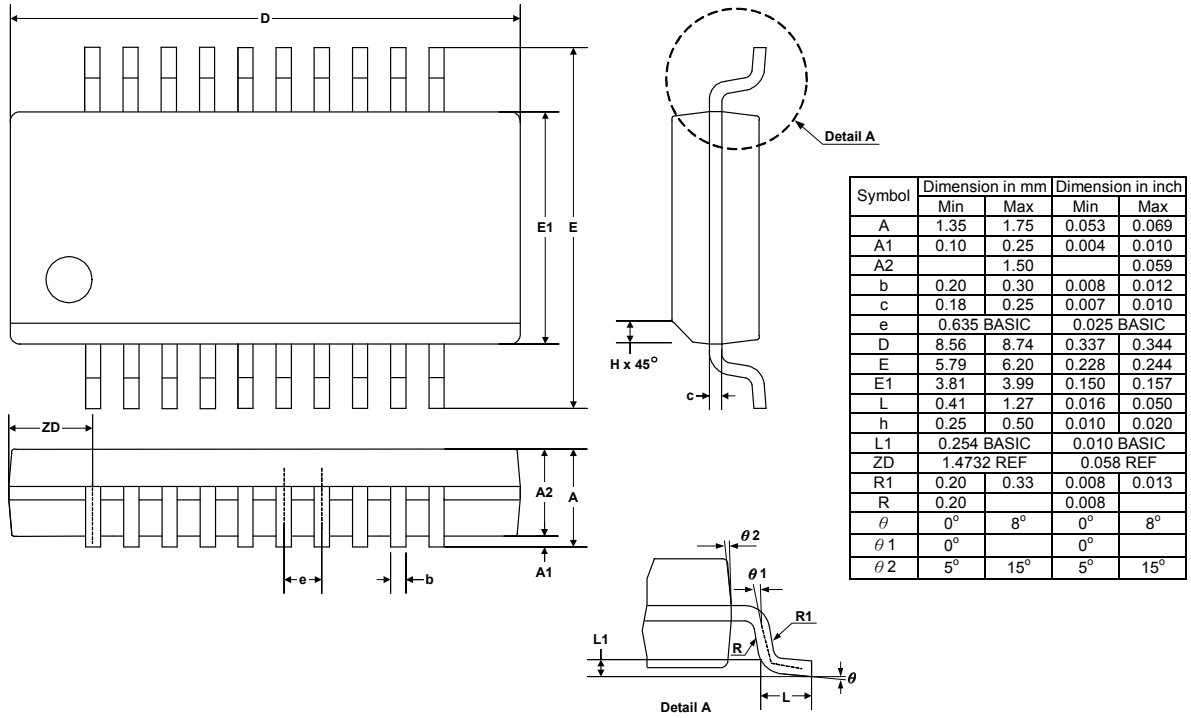

SOP20 (300mil)

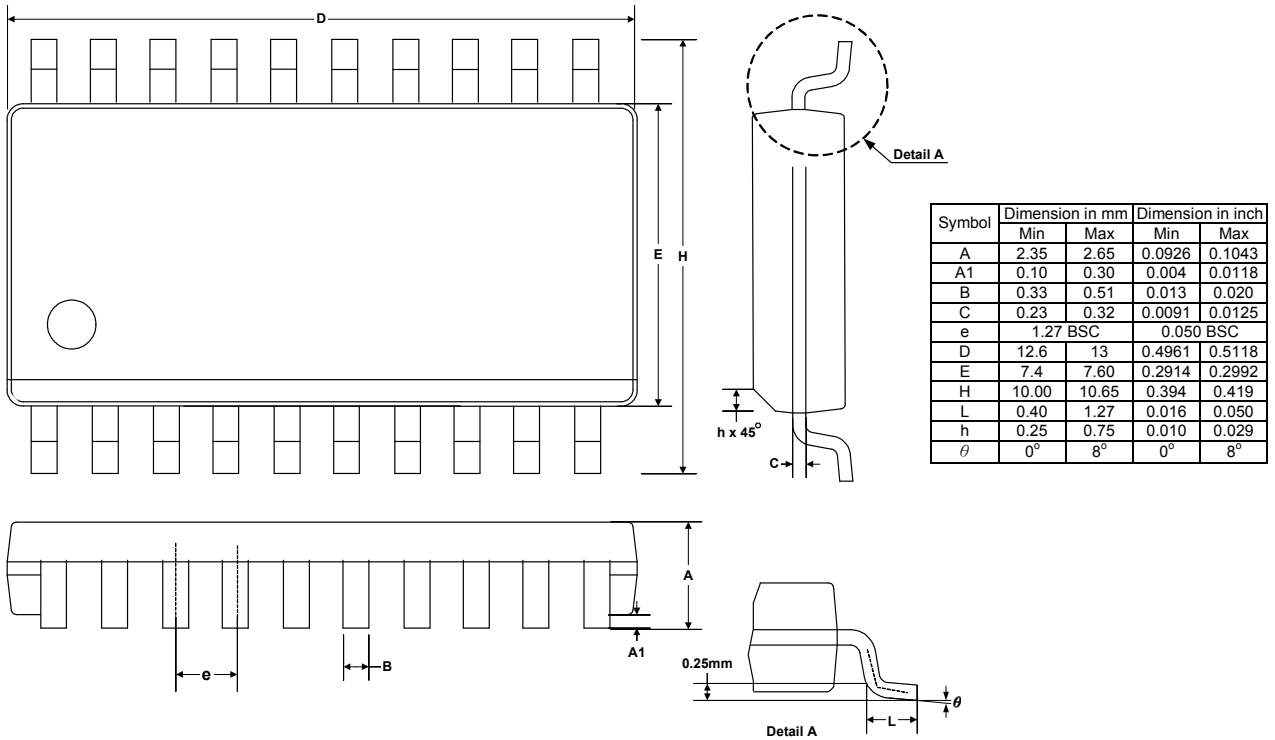

DEMO BOARD

The demo board used IR technique controller to control the MS6715.

The default states of demo board are Volume -20dB, Attenuator Speakers 0dB, Loudness Off, Bass 0dB and Treble 0dB.

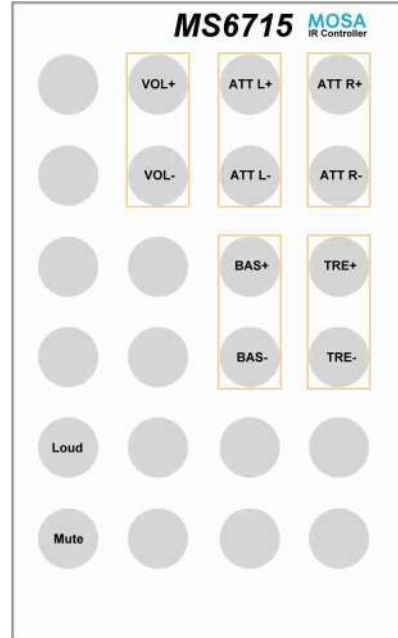
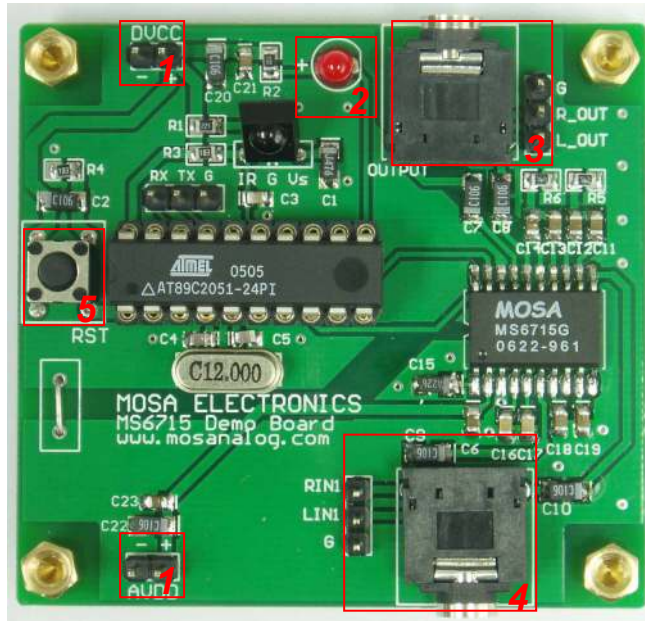

Label 1: Supply Voltage

The AVDD and DVDD should be the same supply voltage, the supply range is 2.7~6.5 VDC.

Label 2: LED Indicator

The LED indicates the power status and the IR received status. It is red-dark blink once when the MCU has received the function code correctly.

Label 3: Output Section

Please connected to a post-power-amplifier, as active speaker.

Label 4: Input Section

Please input stereo audio signal, as music or sine wave.

Label 5: MCU Reset

The MS6715 will be loaded the default values by MCU. The default states of demo board are Volume -20dB, Attenuator Speakers 0dB, Loudness Off, Bass 0dB and Treble 0dB.

IR Controller

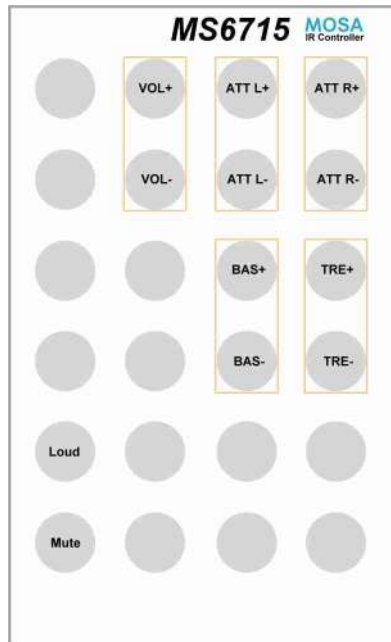

VOL+, VOL- : The volume control keys.

The volume control in 1.25dB/step as the switch is pressed once, the range is -79dB to 0dB.

ATT L+, ATT L- : The attenuation control keys for left speaker output.

The attenuation in 1.25dB/step as the switch is pressed once, the range is -37.5dB to 0dB.

ATT R+, ATT R- : The attenuation control keys for right speaker output.

The attenuation in 1.25dB/step as the switch is pressed once, the range is -37.5dB to 0dB.

TRE+, TRE- : The treble control keys.

The treble control in 2dB/step as the switch is pressed once, the range is -14dB to 14dB.

BAS+, BAS- : The bass control keys.

The bass control in 2dB/step as the switch is pressed once, the range is -14dB to 14dB.

Loud : The loudness key

Press the key once to set loudness on or loudness off.

Mute : The mute key controls all speaker outputs

Press the key once to set mute-on or mute-off.

Circuit

