

High Luminous Efficacy Cool White LED Emitter **LZ9-00CW00**



Key Features

- High Luminous Efficacy, Cool White LED
- CRI 70 minimum
- Can dissipate up to 20W
- Ultra-small foot print – 7.0mm x 7.0mm
- Surface mount ceramic package with integrated glass lens
- Low Thermal Resistance (1.3°C/W)
- Very high Luminous Flux density
- JEDEC Level 1 for Moisture Sensitivity Level
- Autoclave complaint (JEDEC JESD22-A102-C)
- Lead (Pb) free and RoHS compliant
- Reflow solderable (up to 6 cycles)
- Emitter available on MCPCB (optional)
- Full suite of TIR secondary optics family available

Part Number Options

Base part number

Part number	Description
LZ9-00CW00-xxxx	9-die emitter CRI 70 minimum
LZ9-J0CW00-xxxx	9-die emitter CRI 70 minimum on Star MCPCB in 1x9 electrical configuration
LZ9-K0CW00-xxxx	9-die emitter CRI 70 minimum on Star MCPCB in 3x3 electrical configuration

Notes:

1. See "Part Number Nomenclature" for full overview on LED Engin part number.

Bin Kit Option Codes

CW, Cool-White (5000K- 5500K - 6500K)			
Kit number suffix	Min flux Bin	Color Bin Ranges	Description
0000	Y	1U, 1A, 1B, 1V, 1Y, 1D, 1C, 1X, 2U, 2A, 2B, 2V, 2Y, 2D, 2C, 2X, 3U, 3A, 3B, 3V, 3Y, 3D, 3C, 3X	full distribution flux; full distribution CCT (3 ANSI)
0050	Y	2Y, 2D, 2C, 2X, 3U, 3A, 3B, 3V, 3Y, 3D, 3C, 3X	full distribution flux; 5000K bin (1.5 ANSI)
0053	Y	2U, 2A, 2B, 2V, 2Y, 2D, 2C, 2X, 3U, 3A, 3B, 3V, 3Y, 3D, 3C, 3X	full distribution flux; 5300K bin (2 ANSI)
0055	Y	2U, 2Y, 3U, 2A, 2D, 3A, 2B, 2C, 3B, 2V, 2X, 3V	full distribution flux; 5500K bin (1.5 ANSI)
0056	Y	1Y, 1D, 1C, 1X, 2U, 2A, 2B, 2V, 2Y, 2D, 2C, 2X	full distribution flux; 5600K bin (1.5 ANSI)
0060	Y	1U, 1A, 1B, 1V, 1Y, 1D, 1C, 1X, 2U, 2A, 2B, 2V, 2Y, 2D, 2C, 2X	full distribution flux; 6000K bin (2 ANSI)
0065	Y	1U, 1A, 1B, 1V, 1Y, 1D, 1C, 1X, 2U, 2A, 2B, 2V	full distribution flux; 6500K bin (1.5 ANSI)

Note:

1. Default bin kit option is -0000

Cool White Chromaticity Groups

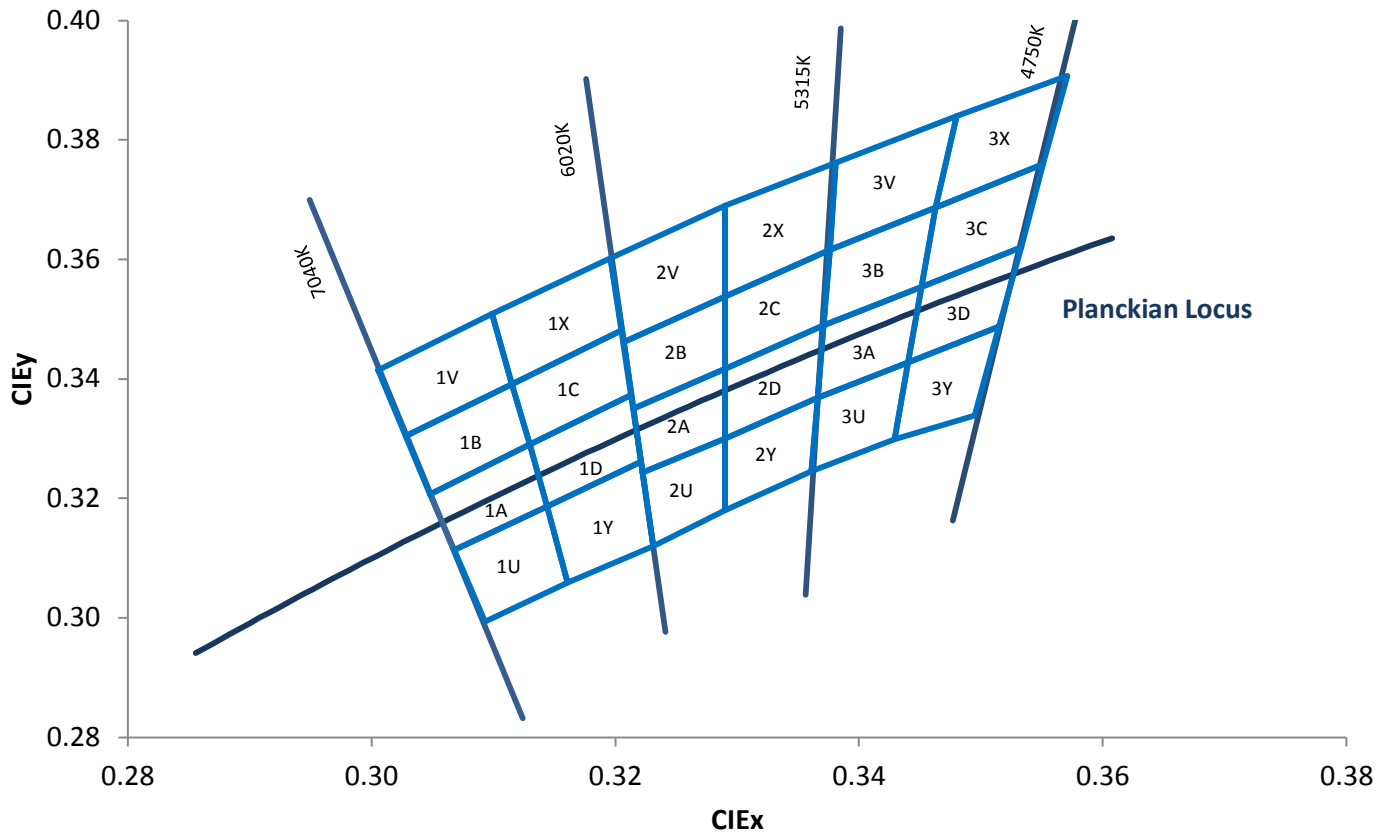

Standard Chromaticity Groups plotted on excerpt from the CIE 1931 (2°) x-y Chromaticity Diagram. Coordinates are listed below in the table.

Cool White Bin Coordinates

Bin code	CIEx	CIEy	Bin code	CIEx	CIEy	Bin code	CIEx	CIEy	Bin code	CIEx	CIEy
1U	0.3068	0.3113	1A	0.3048	0.3207	1B	0.3028	0.3304	1V	0.3005	0.3415
	0.3144	0.3186		0.313	0.329		0.3115	0.3391		0.3099	0.3509
	0.3161	0.3059		0.3144	0.3186		0.313	0.329		0.3115	0.3391
	0.3093	0.2993		0.3068	0.3113		0.3048	0.3207		0.3028	0.3304
	0.3068	0.3113		0.3048	0.3207		0.3028	0.3304		0.3005	0.3415
1Y	0.3144	0.3186	1D	0.313	0.329	1C	0.3115	0.3391	1X	0.3099	0.3509
	0.3221	0.3261		0.3213	0.3373		0.3205	0.3481		0.3196	0.3602
	0.3231	0.312		0.3221	0.3261		0.3213	0.3373		0.3205	0.3481
	0.3161	0.3059		0.3144	0.3186		0.313	0.329		0.3115	0.3391
	0.3144	0.3186		0.313	0.329		0.3115	0.3391		0.3099	0.3509
2U	0.3222	0.3243	2A	0.3215	0.335	2B	0.3207	0.3462	2V	0.3196	0.3602
	0.329	0.33		0.329	0.3417		0.329	0.3538		0.329	0.369
	0.329	0.318		0.329	0.33		0.329	0.3417		0.329	0.3538
	0.3231	0.312		0.3222	0.3243		0.3215	0.335		0.3207	0.3462
	0.3222	0.3243		0.3215	0.335		0.3207	0.3462		0.3196	0.3602
2Y	0.329	0.33	2D	0.329	0.3417	2C	0.329	0.3538	2X	0.329	0.369
	0.3366	0.3369		0.3371	0.349		0.3376	0.3616		0.3381	0.3762
	0.3361	0.3245		0.3366	0.3369		0.3371	0.349		0.3376	0.3616
	0.329	0.318		0.329	0.33		0.329	0.3417		0.329	0.3538
	0.329	0.33		0.329	0.3417		0.329	0.3538		0.329	0.369
3U	0.3366	0.3369	3A	0.3371	0.349	3B	0.3376	0.3616	3V	0.3381	0.3762
	0.344	0.3428		0.3451	0.3554		0.3463	0.3687		0.348	0.384
	0.3429	0.3299		0.344	0.3427		0.3451	0.3554		0.3463	0.3687
	0.3361	0.3245		0.3366	0.3369		0.3371	0.349		0.3376	0.3616
	0.3366	0.3369		0.3371	0.349		0.3376	0.3616		0.3381	0.3762
3Y	0.344	0.3428	3D	0.3451	0.3554	3C	0.3463	0.3687	3X	0.348	0.384
	0.3515	0.3487		0.3533	0.362		0.3551	0.376		0.3571	0.3907
	0.3495	0.3339		0.3515	0.3487		0.3533	0.362		0.3551	0.376
	0.3429	0.3299		0.344	0.3427		0.3451	0.3554		0.3463	0.3687
	0.344	0.3428		0.3451	0.3554		0.3463	0.3687		0.348	0.384

Luminous Flux Bins

Table 1:

Bin Code	Minimum Radiant Flux (Φ_v) @ $I_F = 700\text{mA}$ ^[1,2] (lm)	Maximum Radiant Flux (Φ_v) @ $I_F = 700\text{mA}$ ^[1,2] (lm)
Y	1357	1696
Z	1696	2120

Notes for Table 1:

1. Luminous flux performance guaranteed within published operating conditions. LED Engin maintains a tolerance of $\pm 10\%$ on flux measurements.

Forward Voltage Range per String

Table 2:

Bin Code	Minimum Forward Voltage (V_F) @ $I_F = 700\text{mA}$ ^[1,2] (V)	Maximum Forward Voltage (V_F) @ $I_F = 700\text{mA}$ ^[1,2] (V)
0	9.0	10.8

Notes for Table 2:

1. LED Engin maintains a tolerance of $\pm 0.04\text{V}$ for forward voltage measurements.
2. Forward Voltage per string of 3 LED dies in series.

Absolute Maximum Ratings

Table 3:

Parameter	Symbol	Value	Unit
DC Forward Current at $T_{jmax}=135^{\circ}\text{C}^{[1]}$	I_F	800	mA
DC Forward Current at $T_{jmax}=150^{\circ}\text{C}^{[1]}$	I_F	700	mA
Peak Pulsed Forward Current ^[2]	I_{FP}	1000	mA
Reverse Voltage	V_R	See Note 3	V
Storage Temperature	T_{stg}	-40 ~ +150	$^{\circ}\text{C}$
Junction Temperature	T_J	150	$^{\circ}\text{C}$
Soldering Temperature ^[4]	T_{sol}	260	$^{\circ}\text{C}$
Allowable Reflow Cycles		6	
Autoclave Conditions ^[5]		121 $^{\circ}\text{C}$ at 2 ATM, 100% RH for 168 hours	
ESD Sensitivity ^[6]		> 8,000 V HBM Class 3B JESD22-A114-D	

Notes for Table 3:

- Maximum DC forward current (per die) is determined by the overall thermal resistance and ambient temperature. Follow the curves in Figure 10 for current de-rating.
- Pulse forward current conditions: Pulse Width $\leq 10\text{msec}$ and Duty Cycle $\leq 10\%$.
- LEDs are not designed to be reverse biased.
- Solder conditions per JEDEC 020c. See Reflow Soldering Profile Figure 3.
- Autoclave Conditions per JEDEC JESD22-A102-C.
- LED Engin recommends taking reasonable precautions towards possible ESD damages and handling the LZ9-00CW00 in an electrostatic protected area (EPA). An EPA may be adequately protected by ESD controls as outlined in ANSI/ESD S6.1.

Optical Characteristics @ $T_C = 25^{\circ}\text{C}$

Table 4:

Parameter	Symbol	Typical	Unit
Luminous Flux (@ $I_F = 700\text{mA}$) ^[1]	Φ_v	1700	lm
Luminous Efficacy (@ $I_F = 350\text{mA}$)		100	lm/W
Correlated Color Temperature	CCT	6500	K
Color Rendering Index (CRI)	R_a	75	
Viewing Angle ^[2]	$2\theta_{1/2}$	110	Degrees
Total Included Angle ^[3]	$\theta_{0.9}$	120	Degrees

Notes for Table 4:

- Luminous flux typical value is for all 9 LED dies operating concurrently at rated current.
- Viewing Angle is the off axis angle from emitter centerline where the luminous intensity is $\frac{1}{2}$ of the peak value.
- Total Included Angle is the total angle that includes 90% of the total luminous flux.

Electrical Characteristics @ $T_C = 25^{\circ}\text{C}$

Table 5:

Parameter	Symbol	Typical	Unit
Forward Voltage per String (@ $I_F = 700\text{mA}$)	V_F	9.7	V
Temperature Coefficient of Forward Voltage (per String)	$\Delta V_F / \Delta T_J$	-6.0	mV/ $^{\circ}\text{C}$
Thermal Resistance (Junction to Case)	$R\theta_{J-C}$	1.3	$^{\circ}\text{C}/\text{W}$

IPC/JEDEC Moisture Sensitivity Level

Table 6 - IPC/JEDEC J-STD-20 MSL Classification:

Level	Floor Life		Soak Requirements			
	Time	Conditions	Standard	Accelerated	Time (hrs)	Conditions
1	Unlimited	≤ 30°C/ 85% RH	168 +5/-0	85°C/ 85% RH	n/a	n/a

Notes for Table 1:

1. The standard soak time is the sum of the default value of 24 hours for the semiconductor manufacturer's exposure time (MET) between bake and bag and the floor life of maximum time allowed out of the bag at the end user of distributor's facility.

Average Lumen Maintenance Projections

Lumen maintenance generally describes the ability of a lamp to retain its output over time. The useful lifetime for solid state lighting devices (Power LEDs) is also defined as Lumen Maintenance, with the percentage of the original light output remaining at a defined time period.

Based on accelerated lifetime testing, LED Engin projects that the LZ Series will deliver, on average, 70% Lumen Maintenance at 65,000 hours of operation at a forward current of 700 mA per die. This projection is based on constant current operation with junction temperature maintained at or below 120°C.

Mechanical Dimensions (mm)

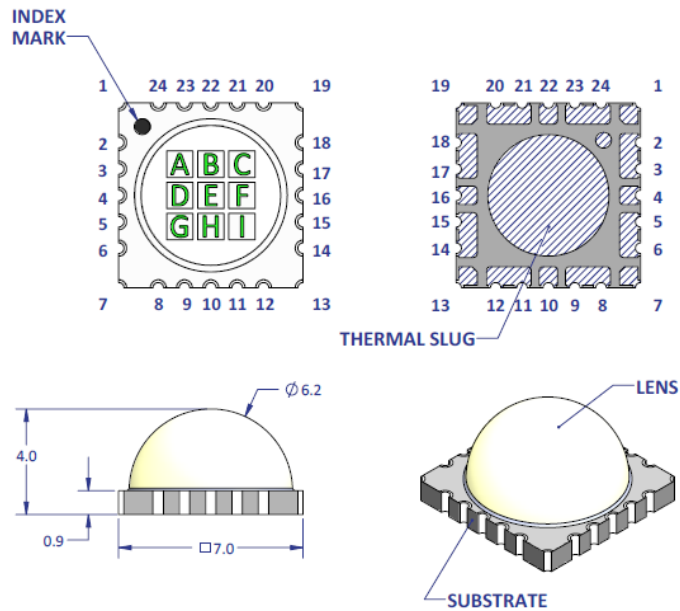

Figure 1: Package outline drawing.

Notes for Figure 1:

1. Unless otherwise noted, the tolerance = ± 0.20 mm.

Recommended Solder Pad Layout (mm)

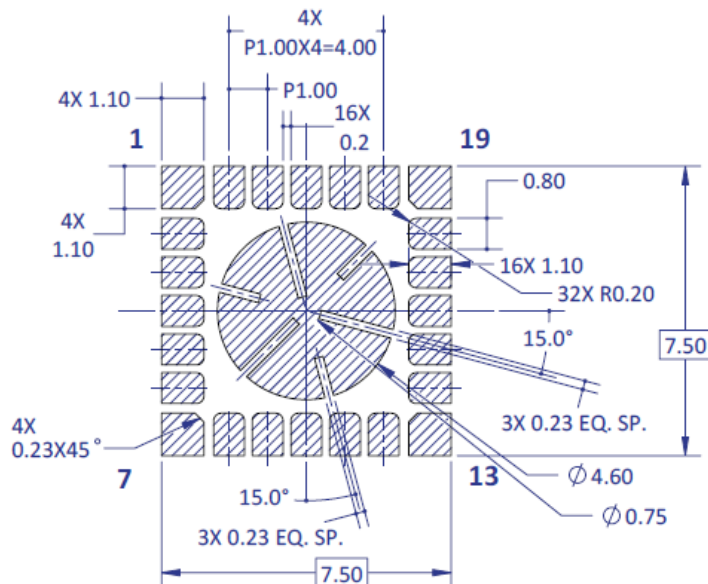

Figure 2a: Recommended solder pad layout for anode, cathode, and thermal pad.

Note for Figure 2a:

1. Unless otherwise noted, the tolerance = ± 0.20 mm.
2. This pad layout is "patent pending".

Emitter pin layout			
Emitter channel	Emitter pin	Die	Color
Ch1 -	23, 24	A	White
Ch1		B	White
Ch1 +	17, 18	E	White
Ch2 -	2, 3	D	White
Ch2		F	White
Ch2 +	14, 15	H	White
Ch3 -	5, 6	C	White
Ch3		G	White
Ch3+	11, 12	I	White
NC pins: 1, 4, 7, 8, 9, 10, 13, 16, 19, 20, 21, 22			
DNC pins: none			

Notes:

NC = Not internally Connected (Electrically isolated)

DNC = Do Not Connect (Electrically Non isolated)

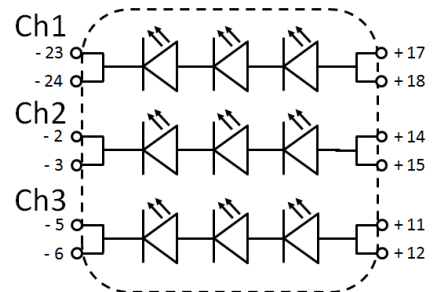

Recommended Solder Mask Layout (mm)

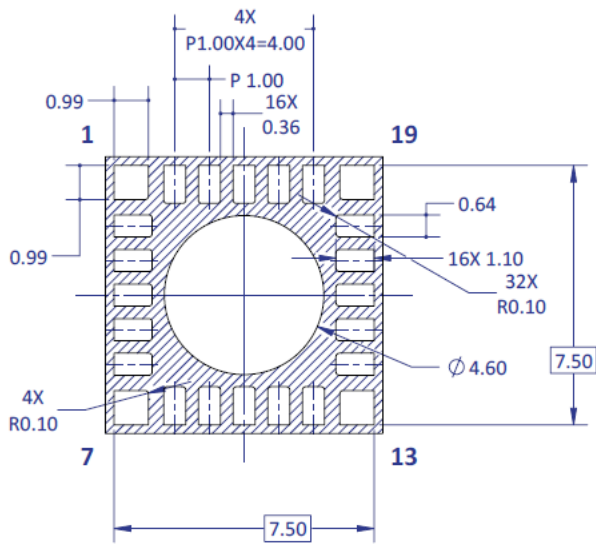

Figure 2b: Recommended solder mask opening (hatched area) for anode, cathode, and thermal pad.

Note for Figure 2b:

1. Unless otherwise noted, the tolerance = ± 0.20 mm.

Reflow Soldering Profile

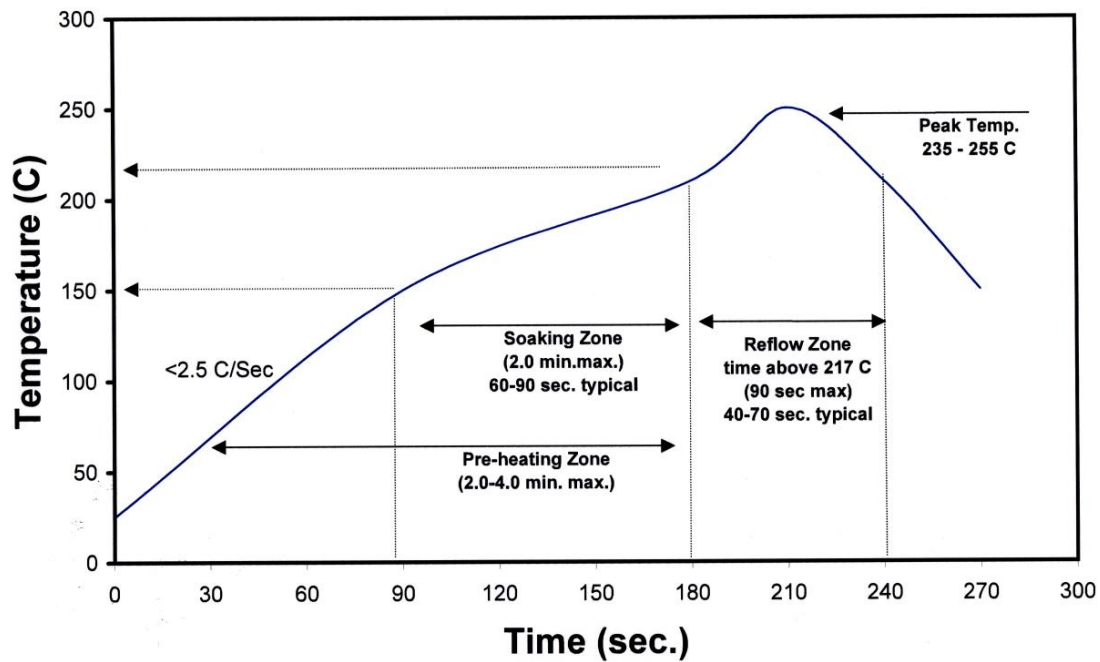

Figure 3: Reflow soldering profile for lead free soldering.

Typical Radiation Pattern

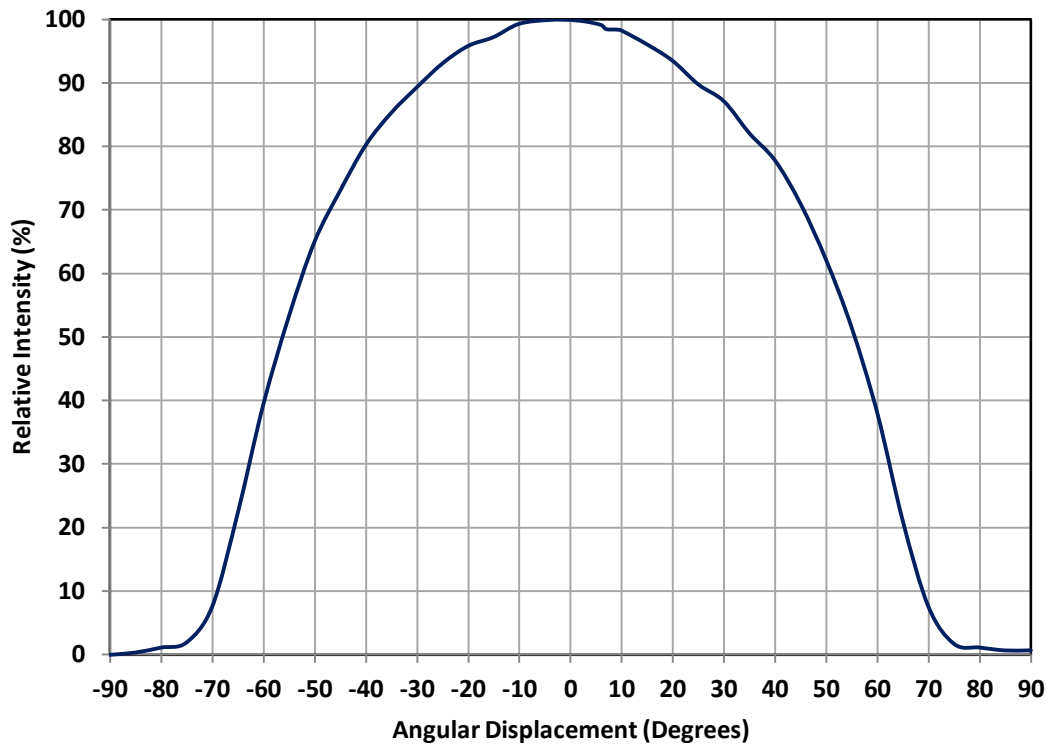

Figure 4: Typical representative spatial radiation pattern.

Typical Relative Spectral Power Distribution

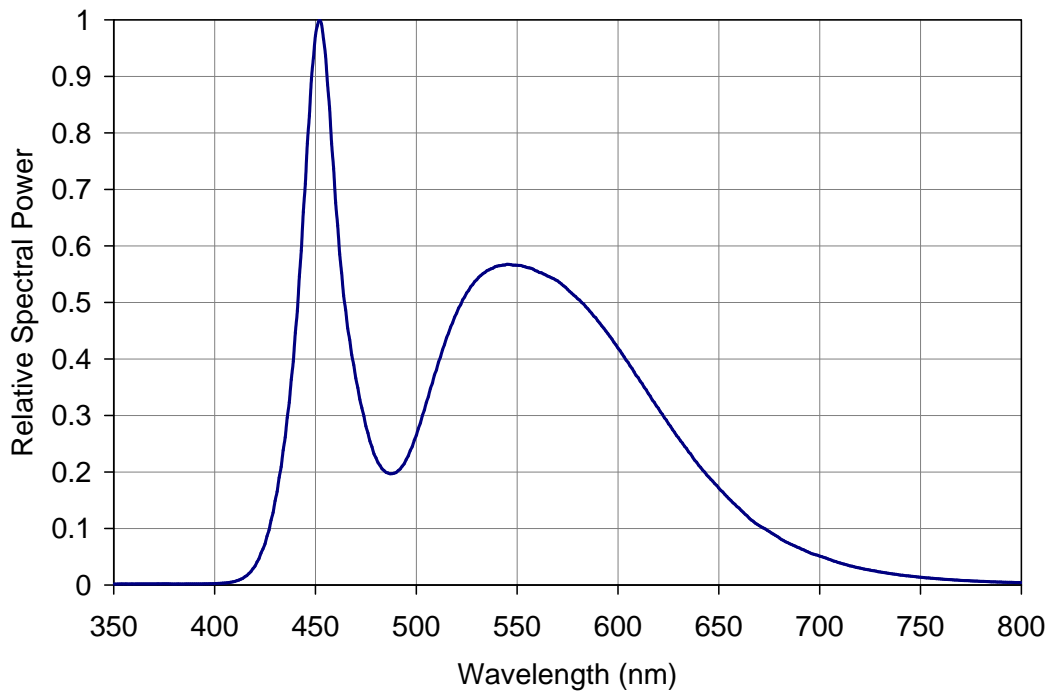

Figure 5: Typical relative spectral power vs. wavelength @ $T_c = 25^\circ\text{C}$

Typical Dominant CCT Shift over Temperature

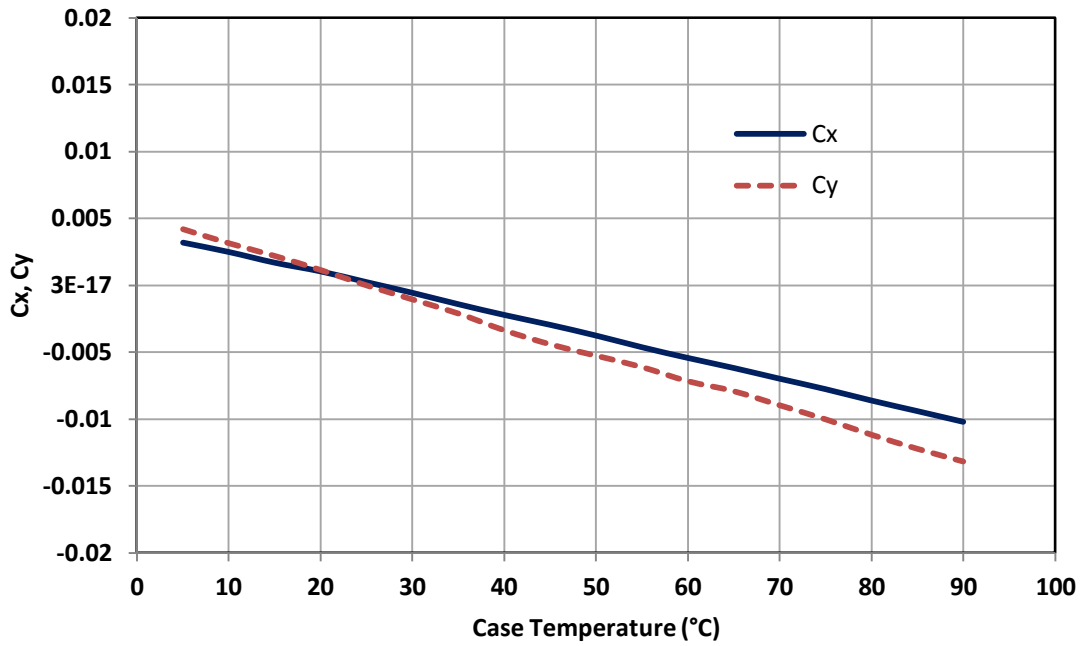

Figure 6: Typical dominant wavelength shift vs. Case temperature.

Typical Relative Light Output

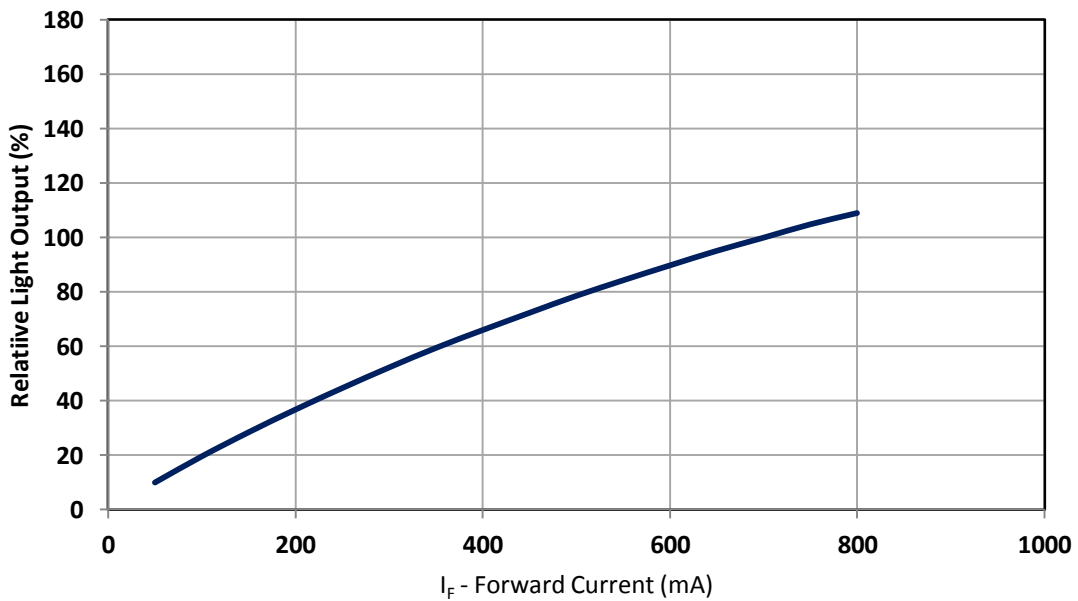

Figure 7: Typical relative light output vs. forward current @ $T_c = 25^\circ\text{C}$.

Typical Normalized Radiant Flux over Temperature

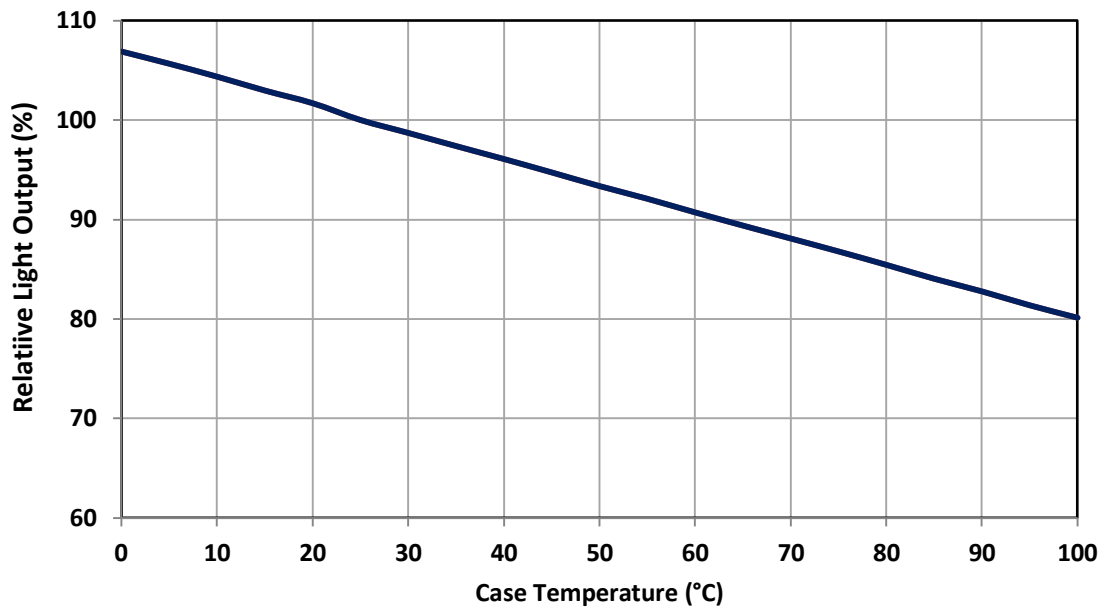

Figure 8: Typical relative light output vs. case temperature.

Typical Forward Voltage Characteristics per String

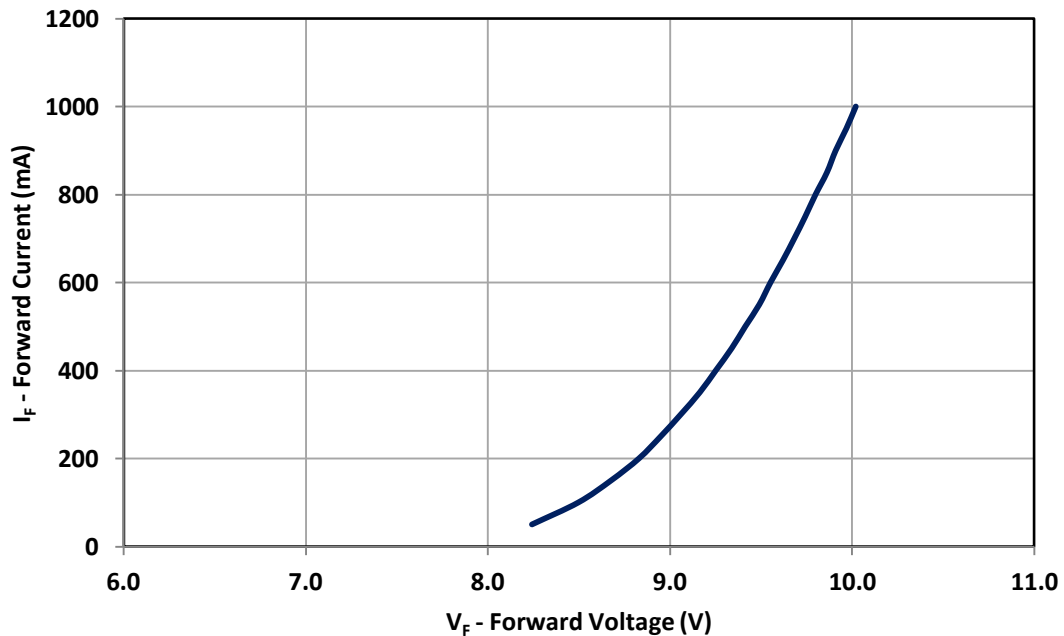

Figure 9: Typical forward current vs. forward voltage¹ @ T_c = 25°C.

Note for Figure 9:

1. Forward Voltage per string of 3 LED dies connected in series.

Current De-rating

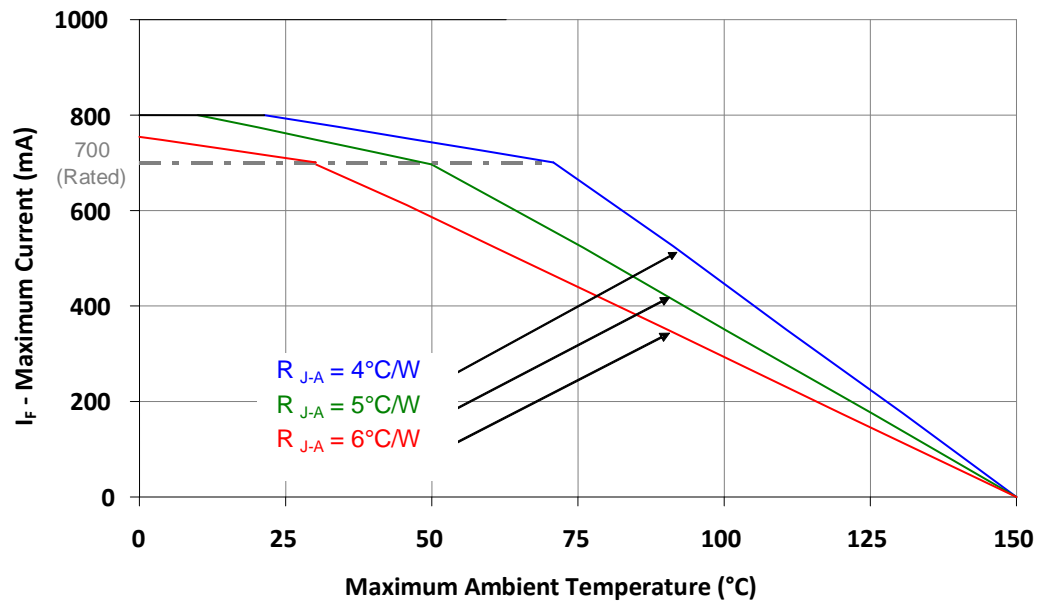

Figure 10: Maximum forward current vs. ambient temperature based on $T_{J(MAX)} = 150^{\circ}\text{C}$.

Notes for Figure 10:

1. Maximum current assumes that all 9 LED dice are operating concurrently at the same current.
2. RO_{J-C} [Junction to Case Thermal Resistance] for the LZ9-00CW00 is typically 1.3°C/W .
3. RO_{J-A} [Junction to Ambient Thermal Resistance] = $RO_{J-C} + RO_{C-A}$ [Case to Ambient Thermal Resistance].

Emitter Tape and Reel Specifications (mm)

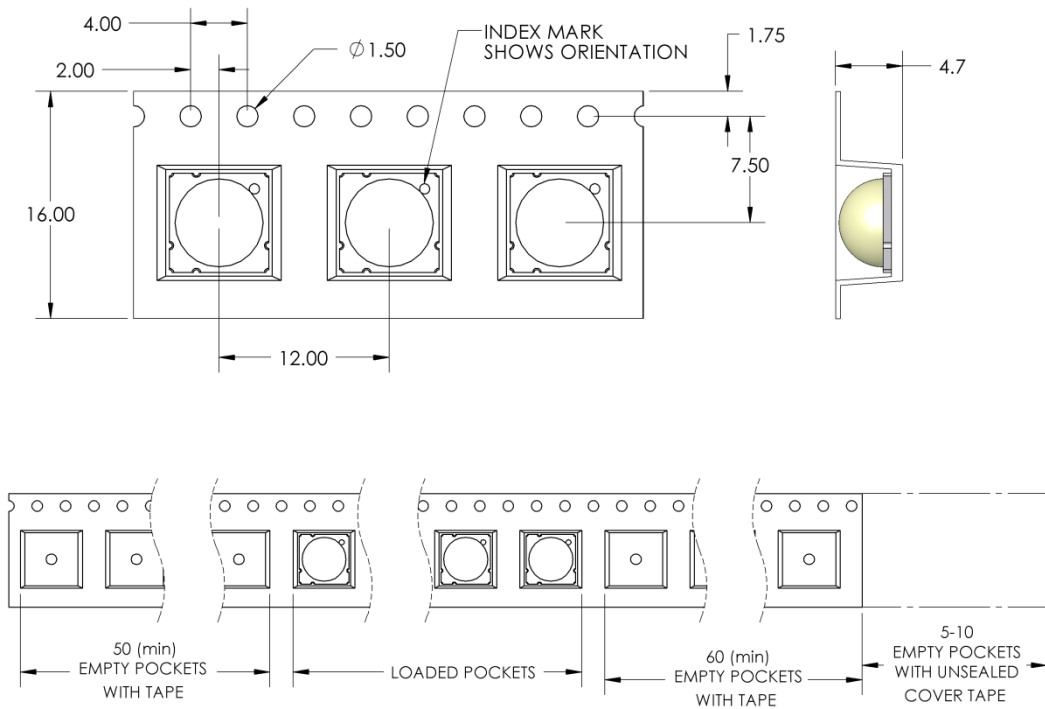

Figure 11: Emitter carrier tape specifications (mm).

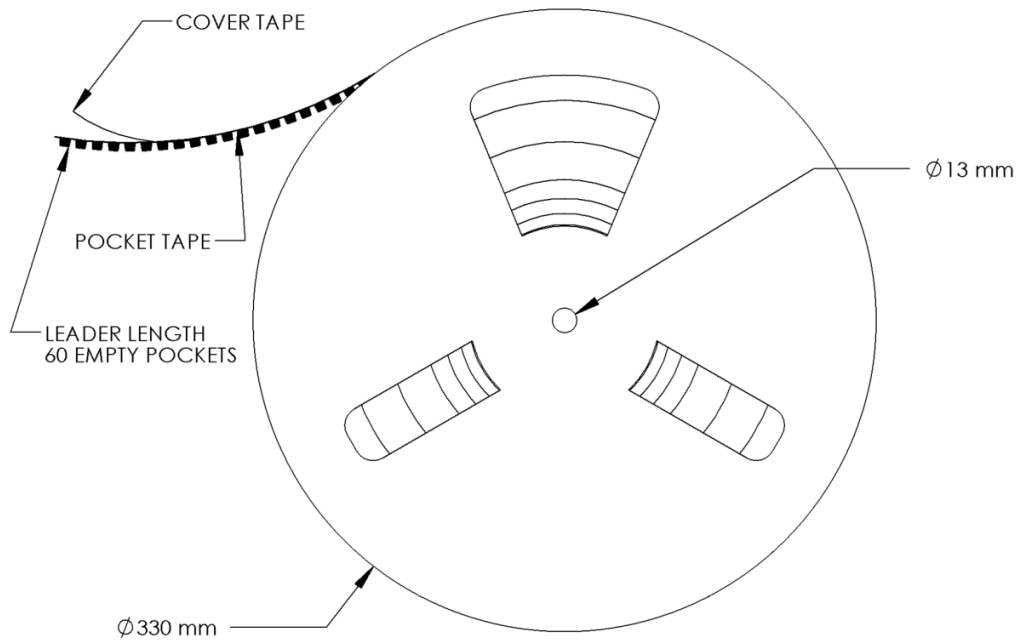

Figure 12: Emitter Reel specifications (mm).

Part-number Nomenclature

The LZ Series base part number designation is defined as follows:

L Z A – B C D E F G – H I J K

A – designates the number of LED die in the package

- 1 for single die emitter package
- 4 for 4-die emitter package
- 9 for 9-die emitter package
- C for 12-die emitter package
- P for 25-die emitter package

B – designates the package level

- 0 for Emitter only

Other letters indicate the addition of a MCPCB. See appendix “MCPCB options” for details

C – designates the radiation pattern

- 0 for Clear domed lens (Lambertian radiation pattern)
- 1 for Flat-top
- 3 for Frosted domed lens

D and E – designates the color

- U6 Ultra Violet (365nm)
- UA Violet (400nm)
- DB Dental Blue (460nm)
- B2 Blue (465nm)
- G1 Green (525nm)
- A1 Amber (590nm)
- R1 Red (623nm)
- R2 Deep Red (660nm)
- R3 Far Red (740nm)
- R4 Infrared (850nm)
- WW Warm White (2700K-3500K)
- W9 Warm White CRI 90 Minimum (2700K-3500K)
- NW Neutral White (4000K)
- CW Cool White (5500K-6500K)
- W2 Warm & Cool White mixed dies
- MC RGB
- MA RGBA
- MD RGBW (6500K)

F and G – designates the package options if applicable

See “Base part number” on page 2 for details. Default is “00”

H, I, J, K – designates kit options

See “Bin kit options” on page 2 for details. Default is “0000”

Ordering information:

For ordering LED Engin products, please reference the base part number above. The base part number represents our standard full distribution flux and wavelength range. Other standard bin combinations can be found on page 2. For ordering products with custom bin selections, please contact a LED Engin sales representative or authorized distributor.

LZ9 MCPCB Family

Part number	Type of MCPCB	Diameter (mm)	Emitter + MCPCB Thermal Resistance (°C/W)	Typical V _f (V)	Typical I _f (mA)
LZ9-Jxxxxxx	1-channel (1x9 string)	19.9	1.3 + 0.2 = 1.5	29.1	700
LZ9-Kxxxxxx	1-channel (3x3 strings)	19.9	1.3 + 0.2 = 1.5	9.7	2100

▪ Mechanical Mounting of MCPCB

- Mechanical stress on the emitter that could be caused by bending the MCPCB should be avoided. The stress can cause the substrate to crack and as a result might lead to cracks in the dies.
- Therefore special attention needs to be paid to the flatness of the heat sink surface and the torque on the screws. Maximum torque should not exceed 1 Nm (8.9 lbf/in).
- Care must be taken when securing the board to the heatsink to eliminate bending of the MCPCB. This can be done by tightening the three M3 screws (or #4-40) in steps and not all at once. This is analogous to tightening a wheel of an automobile
- It is recommended to always use plastic washers in combination with three screws. Two screws could more easily lead to bending of the board.
- If non taped holes are used with self-tapping screws it is advised to back out the screws slightly after tighten (with controlled torque) and retighten the screws again.

▪ Thermal interface material

- To properly transfer the heat from the LED to the heatsink a thermally conductive material is required when mounting the MCPCB to the heatsink
- There are several materials which can be used as thermal interface material, such as thermal paste, thermal pads, phase change materials and thermal epoxies. Each has pro's and con's depending on the application. For our emitter it is critical to verify that the thermal resistance is sufficient for the selected emitter and its environment.
- To properly transfer the heat from the MCPCB to the heatsink also special attention should be paid to the flatness of the heatsink.

▪ Wire soldering

- For easy soldering of wires to the MCPCB it is advised to preheat the MCPCB on a hot plate to a maximum of 150°. Subsequently apply the solder and additional heat from the solder iron to initiate a good solder reflow. It is recommended to use a solder iron of more than 60W. We advise to use lead free, no-clean solder. For example SN-96.5 AG-3.0 CU 0.5 #58/275 from Kester (pn: 24-7068-7601)

LZ9-Jxxxxx

1 channel, Standard Star MCPCB (1x9) Dimensions (mm)

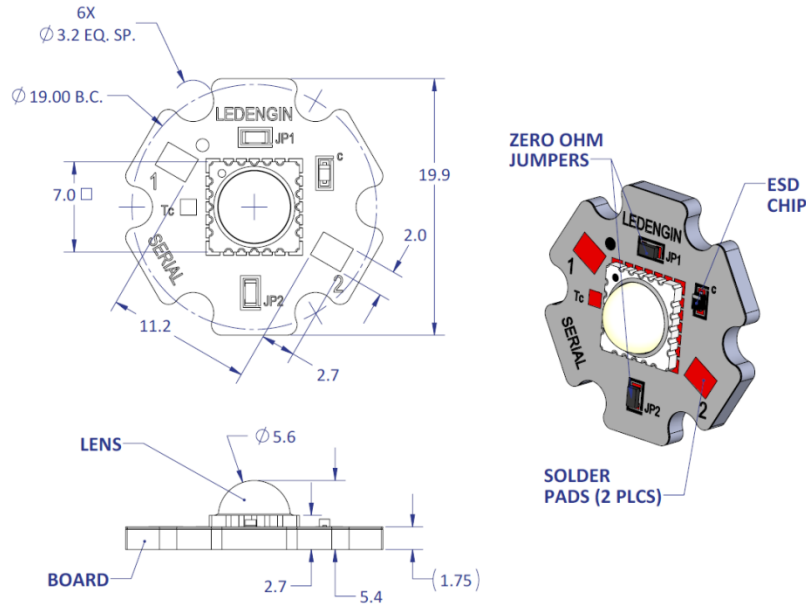

Notes:

- Unless otherwise noted, the tolerance = ± 0.2 mm.
- Slots in MCPCB are for M3 or #4-40 mounting screws.
- LED Engin recommends plastic washers to electrically insulate screws from solder pads and electrical traces.
- LED Engin recommends using thermal interface material when attaching the MCPCB to a heatsink.
- The thermal resistance of the MCPCB is: R θ C-B 0.2°C/W. This low thermal resistance is possible by utilizing a copper based MCPCB with pedestal design. The emitter thermal slug is in direct contact with the copper core. There are several vendors that offer similar solutions, some of them are: Bridge-Semiconductor, Rayben, Bergquist, SinkPad.

Components used

MCPCB: MHE-301 copper (Rayben)
 ESD chips: BZX585-C47 (NXP, for 9 LED die)
 Jumpers: CRCW06030000Z0 (Vishay)

Pad layout			
Ch.	MCPCB Pad	String/die	Function
1	1	1/ABCDEF	Cathode -
	2	GHI	Anode +

LZ9-Kxxxxx

1 channel, Standard Star MCPCB (3x3) Dimensions (mm)

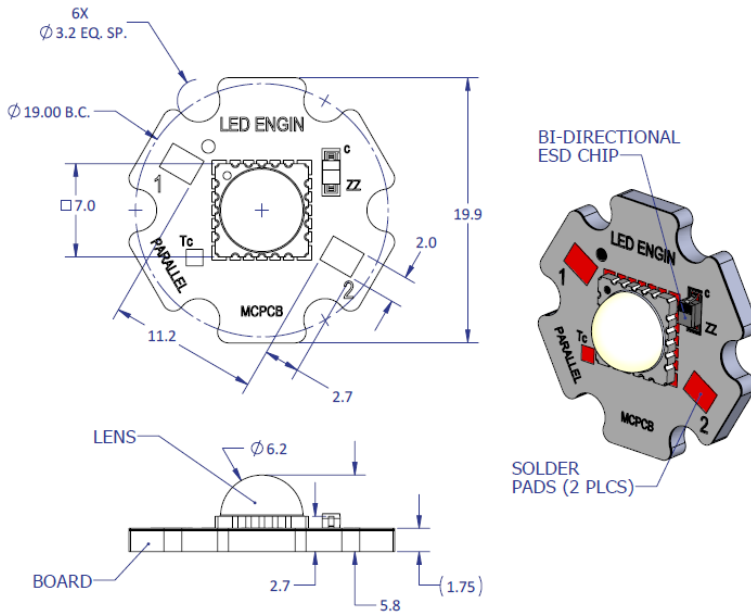

Notes:

- Unless otherwise noted, the tolerance = ± 0.2 mm.
- Slots in MCPCB are for M3 or #4-40 mounting screws.
- LED Engin recommends plastic washers to electrically insulate screws from solder pads and electrical traces.
- LED Engin recommends using thermal interface material when attaching the MCPCB to a heatsink.
- The thermal resistance of the MCPCB is: $\theta_{JC-B} 0.2^{\circ}\text{C}/\text{W}$. This low thermal resistance is possible by utilizing a copper based MCPCB with pedestal design. The emitter thermal slug is in direct contact with the copper core. There are several vendors that offer similar solutions, some of them are: Bridge-Semiconductor, Rayben, Bergquist, SinkPad.

Components used

MCPCB: MHE-301 copper (Rayben)
 ESD chips: PESD1LIN,115 (NXP, for 3 LED die)

Pad layout			
Ch.	MCPCB Pad	String/die	Function
1	1	1/ABE	Cathode -
	2	2/DFH	
		3/CGI	Anode +

LZ9 secondary TIR optics family

LLxx-3T06-H

Optical Specification

Part number ¹	Beam angle ²	Field angle ³	Optical efficiency ⁴	On-axis intensity ⁵
	degrees	degrees	%	cd/lm
LLSP-3T06-H	17	36	90	5.4
LLNF-3T06-H	26	49	90	2.2
LLFL-3T06-H	39	83	90	1.2

Notes:

1. Lenses can also be ordered without the holder. Replace -H with -O for this option.
2. Beam angle is defined as the full width at 50% of the max intensity (FWHM).
3. Field angle is defined as the full width at 10% of the max intensity.
4. Optical efficiency is defined as the ratio between the incoming flux and the outgoing flux.
5. On-axis intensity is defined as the ratio between the total input lumen and the intensity in the optical center of the lens.

Typical Relative Intensity over Angle

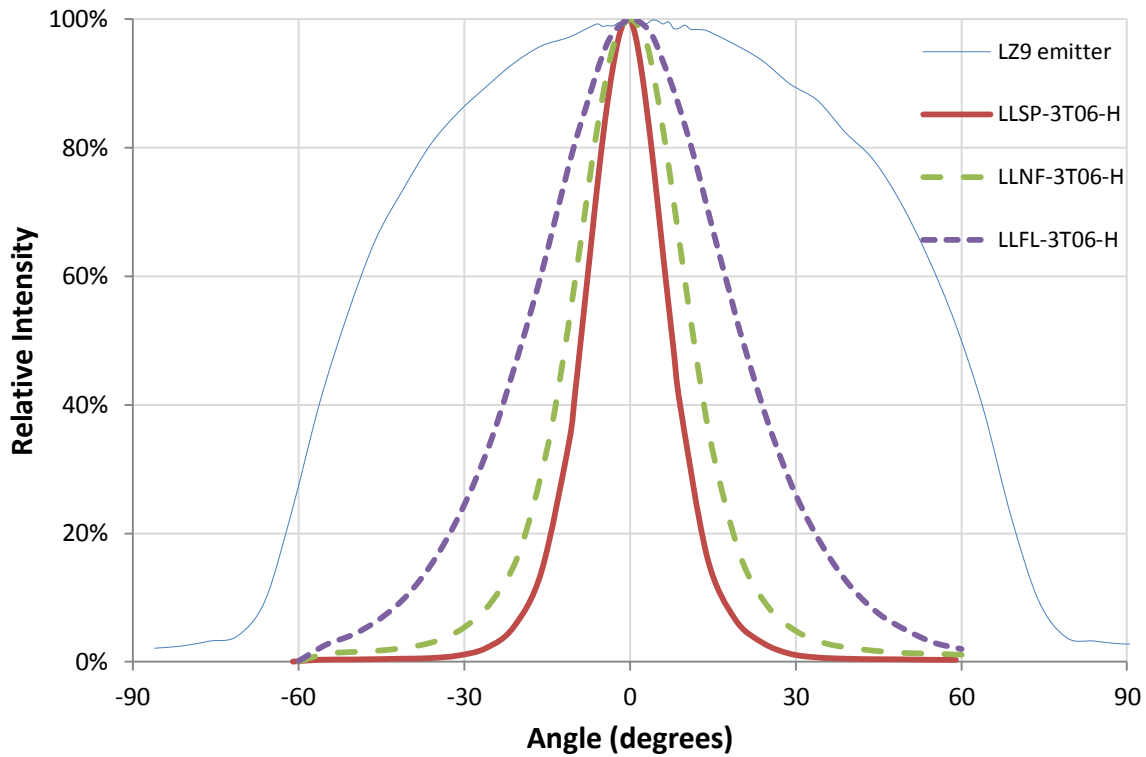

General Characteristics

	Symbol	Value	Rating	Unit
Mechanical				
Height from Seating Plane		19.20	Typical	mm
Width		38.90	Typical	mm
Material				
Lens		PMMA		
Holder		Polycarbonate		
Optical				
Transmission ¹ (>90%)	λ	410-1100	Min-Max.	nm
Environmental				
Storage Temperature	T_{stg}	-40 ~ +110	Min-Max.	°C
Operating Temperature	T_{sol}	-40 ~ +110	Min-Max.	°C

Notes:

1. It is not recommended to use a UV emitter with this lens due to lower transmission at wavelengths < 410nm.

Mechanical dimensions

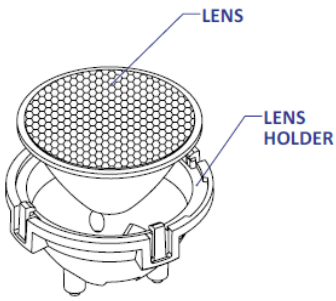

Lens with Holder

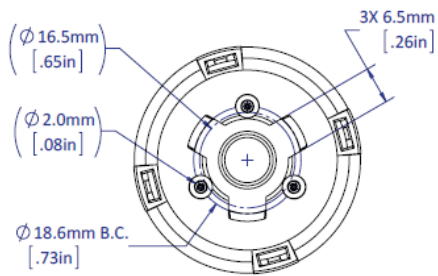
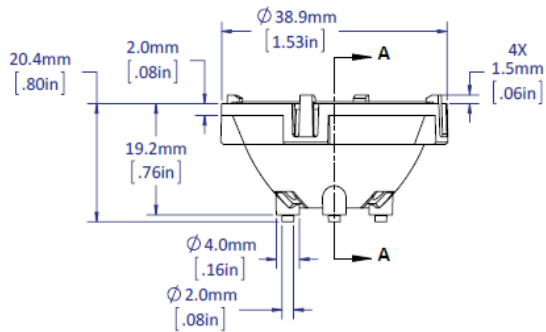

Lens

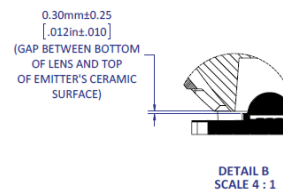
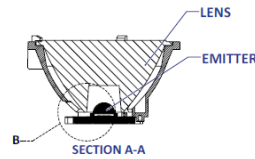
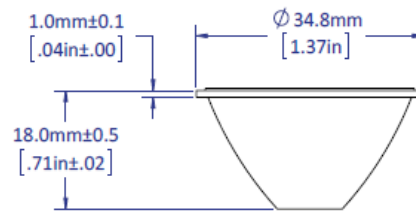

Company Information

LED Engin, Inc., based in California's Silicon Valley, specializes in ultra-bright, ultra compact solid state lighting solutions allowing lighting designers & engineers the freedom to create uncompromised yet energy efficient lighting experiences. The LuxiGen™ Platform — an emitter and lens combination or integrated module solution, delivers superior flexibility in light output, ranging from 3w to 90w, a wide spectrum of available colors, including whites, multi-color and UV, and the ability to deliver upwards of 5,000 high quality lumens to a target. The small size combined with powerful output allows for a previously unobtainable freedom of design wherever high-flux density, directional light is required. LED Engin's packaging technologies lead the industry with products that feature lowest thermal resistance, highest flux density and consummate reliability, enabling compact and efficient solid state lighting solutions.

LED Engin is committed to providing products that conserve natural resources and reduce greenhouse emissions.

LED Engin reserves the right to make changes to improve performance without notice.

Please contact sales@ledengin.com or (408) 922-7200 for more information.