

1. SCOPE

1.1 Scope. This drawing describes device requirements for class B microcircuits in accordance with 1.2.1 of MIL-STD-883, "Provisions for the use of MIL-STD-883 in conjunction with compliant non-JAN devices".

1.2 Part number. The complete part number shall be as shown in the following example:

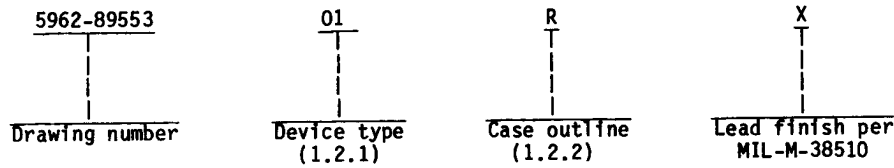

1.2.1 Device type. The device type shall identify the circuit function as follows:

Device type	Generic number	Circuit function
01	54AS640	Octal bus transceivers with three-state outputs

1.2.2 Case outlines. The case outlines shall be as designated in appendix C of MIL-M-38510, and as follows:

Outline letter	Case outline
R	D-8 (20-lead, 1.060" x .310" x .200"), dual-in-line package
S	F-9 (20-lead, .540" x .300" x .100"), flat package
2	C-2 (20-terminal, .358" x .358" x .100"), square chip carrier package

1.3 Absolute maximum ratings.

Supply voltage range	-0.5 V dc minimum to +7.0 V dc maximum
Input voltage range:	
V _{CC} all inputs	0.0 V dc to +7.0 V dc
V _{CC} I/O ports	0.0 V dc to +5.5 V dc
Continuous power dissipation (P _D) 1/	676 mW
Storage temperature range	-65°C to +150°C
Lead temperature (soldering, 10 seconds)	+300°C
Thermal resistance, junction-to-case (θ _{JC})	See MIL-M-38510, appendix C.
Junction temperature (T _J)	175°C

1.4 Recommended operating conditions.

Supply voltage range (V _{CC})	+4.5 V dc minimum to +5.5 V dc maximum
Minimum high level input voltage (V _{IH})	2.0 V dc
Maximum low level input voltage (V _{IL})	0.8 V dc
Maximum high level output current (I _{OH})	-12 mA
Maximum low level output current (I _{OL})	48 mA
Case operating temperature range (T _C)	-55°C to +125°C

1/ Must withstand the added P_D due to output current test; e.g., I_O.

STANDARDIZED MILITARY DRAWING DEFENSE ELECTRONICS SUPPLY CENTER DAYTON, OHIO 45444	SIZE A	5962-89553
	REVISION LEVEL	SHEET 2

2. APPLICABLE DOCUMENTS

2.1 Government specification and standard. Unless otherwise specified, the following specification and standard, of the issue listed in that issue of the Department of Defense Index of Specifications and Standards specified in the solicitation, form a part of this drawing to the extent specified herein.

SPECIFICATION

MILITARY

MIL-M-38510 - Microcircuits, General Specification for.

STANDARD

MILITARY

MIL-STD-883 - Test Methods and Procedures for Microelectronics.

(Copies of the specification and standard required by manufacturers in connection with specific acquisition functions should be obtained from the contracting activity or as directed by the contracting activity.)

2.2 Order of precedence. In the event of a conflict between the text of this drawing and the references cited herein, the text of this drawing shall take precedence.

3. REQUIREMENTS

3.1 Item requirements. The individual item requirements shall be in accordance with 1.2.1 of MIL-STD-883, "Provisions for the use of MIL-STD-883 in conjunction with compliant non-JAN devices" and as specified herein.

3.2 Design, construction, and physical dimensions. The design, construction, and physical dimensions shall be as specified in MIL-M-38510 and herein.

3.2.1 Terminal connections. The terminal connections shall be as specified on figure 1.

3.2.2 Truth table. The truth table shall be as specified on figure 2.

3.2.3 Test circuit and switching waveforms. The test circuit and switching waveforms shall be as specified on figure 3.

3.2.4 Case outlines. The case outlines shall be in accordance with 1.2.2 herein.

3.3 Electrical performance characteristics. Unless otherwise specified, the electrical performance characteristics are as specified in table I and apply over the full case operating temperature range.

3.4 Marking. Marking shall be in accordance with MIL-STD-883 (see 3.1 herein). The part shall be marked with the part number listed in 1.2 herein. In addition, the manufacturer's part number may also be marked as listed in 6.4 herein.

3.5 Certificate of compliance. A certificate of compliance shall be required from a manufacturer in order to be listed as an approved source of supply in 6.4. The certificate of compliance submitted to DESC-ECS prior to listing as an approved source of supply shall state that the manufacturer's product meets the requirements of MIL-STD-883 (see 3.1 herein) and the requirements herein.

STANDARDIZED MILITARY DRAWING DEFENSE ELECTRONICS SUPPLY CENTER DAYTON, OHIO 45444	SIZE A	5962-89553
	REVISION LEVEL	SHEET 3

DESC FORM 193A
SEP 87

☆ U. S. GOVERNMENT PRINTING OFFICE: 1988-550-547

TABLE I. Electrical performance characteristics.

Test	Symbol	Conditions -55°C < T _c < +125°C unless otherwise specified		Group A subgroups	Limits		Unit
					Min	Max	
High level output voltage	V _{OH}	V _{CC} = 4.5 V V _{IH} = 2.0 V V _{IL} = 0.8 V	I _{OH} = -2.0 mA	1,2,3	2.5		V
			I _{OH} = -3.0 mA		2.4		
			I _{OH} = -12 mA		2.4		
Low level output voltage	V _{OL}	V _{CC} = 4.5 V V _{IL} = 0.8 V V _{IH} = 2.0 V	I _{OL} = 48 mA	1,2,3		0.55	V
Input clamp voltage	V _{IC}	V _{CC} = 4.5 V	I _{IN} = -18 mA	1,2,3		-1.2	V
High level input current	I _{IH1}	V _{CC} = 5.5 V V _{IN} = 2.7 V	Control inputs	1,2,3		20	μA
			A or B ports 1/			70	
	I _{IH2}	V _{CC} = 5.5 V V _{IN} = 5.5 V	A or B ports	1,2,3		0.1	mA
	V _{CC} = 5.5 V V _{IN} = 7.0 V	Control inputs			0.1		
Low level input current	I _{IL}	V _{CC} = 5.5 V V _{IN} = 0.4 V	Control inputs	1,2,3		-0.5	mA
			A or B ports 1/			-0.75	
Output current	I _O	V _{CC} = 5.5 V V _{OUT} = 2.25 V 2/		1,2,3	-50	-150	mA
Supply current	I _{CCH}	V _{CC} = 5.5 V V _{IN} = GND or 4.5 V		1,2,3		58	mA
	I _{CCL}					123	
	I _{CCZ}					80	
Functional tests		See 4.3.1c		7,8			

See footnotes at end of table.

STANDARDIZED MILITARY DRAWING DEFENSE ELECTRONICS SUPPLY CENTER DAYTON, OHIO 45444	SIZE A		5962-89553
		REVISION LEVEL	SHEET 4

TABLE I. Electrical performance characteristics - Continued.

Test	Symbol	Conditions -55°C < T _C < +125°C unless otherwise specified	Group A subgroups	Limits		Unit
				Min	Max	
Propagation delay time, A, B to B, A	t _{PLH}	V _{CC} = 4.5 V to 5.5 V C _L = 50 pF R ₁ = 500Ω R ₂ = 500Ω See figure 3	9,10,11	1	8	ns
	t _{PHL}			1	7	
Output enable time, G to A, B	t _{PZH}		9,10,11	2	10	
	t _{PZL}			2	12	
Output disable time, G to A, B	t _{PHZ}		9,10,11	2	9	
	t _{PLZ}			2	16	

1/ Includes the off-state output current.

2/ The output conditions have been chosen to produce a current that closely approximates one half of the true short-circuit output current, I_{OS}.

**STANDARDIZED
MILITARY DRAWING**

DEFENSE ELECTRONICS SUPPLY CENTER
DAYTON, OHIO 45444

SIZE
A

5962-89553

REVISION LEVEL

SHEET

5

DESC FORM 193A
SEP 87

U. S. GOVERNMENT PRINTING OFFICE: 1988-550-547

Case outlines R, S, and 2	
Terminal number	Terminal symbol
1	DIR
2	A1
3	A2
4	A3
5	A4
6	A5
7	A6
8	A7
9	A8
10	GND
11	B8
12	B7
13	B6
14	B5
15	B4
16	B3
17	B2
18	B1
19	\bar{E}
20	V _{CC}

Control inputs		Operation
\bar{E}	DIR	
L	L	\bar{B} data to A bus
L	H	\bar{A} data to B bus
H	X	Isolation

H = High voltage level
L = Low voltage level
X = Irrelevant

FIGURE 1. Terminal connections.

FIGURE 2. Truth table.

STANDARDIZED MILITARY DRAWING DEFENSE ELECTRONICS SUPPLY CENTER DAYTON, OHIO 45444	SIZE A		5962-89553
		REVISION LEVEL	SHEET 6

DESC FORM 193A
SEP 87

* U. S. GOVERNMENT PRINTING OFFICE: 1988-550-547

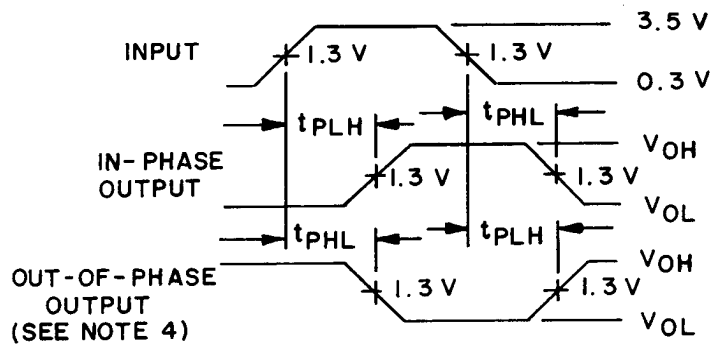
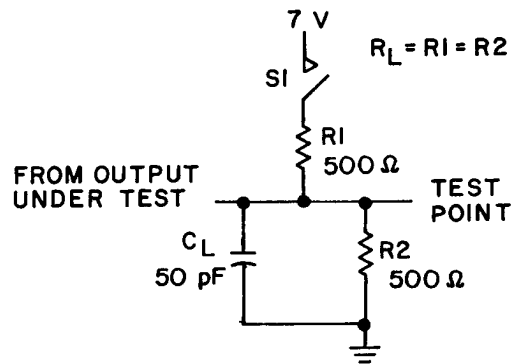

VOLTAGE WAVEFORMS
PROPAGATION DELAY TIMES

See notes on the next page.

FIGURE 3. Test circuit and switching waveforms.

STANDARDIZED MILITARY DRAWING DEFENSE ELECTRONICS SUPPLY CENTER DAYTON, OHIO 45444	SIZE A	5962-89553	
		REVISION LEVEL	SHEET 7

DESC FORM 193A
SEP 87

U. S. GOVERNMENT PRINTING OFFICE: 1988-550-547

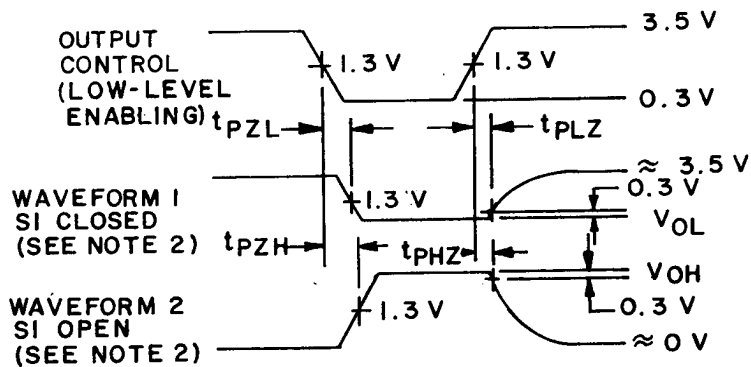

VOLTAGE WAVEFORMS
ENABLE AND DISABLE TIMES, THREE-STATE OUTPUTS

NOTES:

1. C_L includes probe and jig capacitance.
2. Waveform 1 is for an output with internal conditions such that the output is low except when disabled by the output control. Waveform 2 is for an output with internal conditions such that the output is high except when disabled by the output control.
3. All input pulses have the following characteristics: $PRR \leq 10$ MHz, $t_r = t_f = 3$ ns ± 1 ns, duty cycle = 50%.
4. When measuring propagation delay items of three-state outputs, switch S1 is open.
5. The outputs are measured one at a time with one input transition per measurement.

FIGURE 3. Test circuit and switching waveforms - Continued.

STANDARDIZED MILITARY DRAWING DEFENSE ELECTRONICS SUPPLY CENTER DAYTON, OHIO 45444	SIZE A	5962-89553
		REVISION LEVEL

DESC FORM 193A
SEP 87

U. S. GOVERNMENT PRINTING OFFICE: 1968-550-547

3.6 Certificate of conformance. A certificate of conformance as required in MIL-STD-883 (see 3.1 herein) shall be provided with each lot of microcircuits delivered to this drawing.

3.7 Notification of change. Notification of change to DESC-ECS shall be required in accordance with MIL-STD-883 (see 3.1 herein).

3.8 Verification and review. DESC, DESC's agent, and the acquiring activity retain the option to review the manufacturer's facility and applicable required documentation. Offshore documentation shall be made available onshore at the option of the reviewer.

4. **QUALITY ASSURANCE PROVISIONS**

4.1 Sampling and inspection. Sampling and inspection procedures shall be in accordance with section 4 of MIL-M-38510 to the extent specified in MIL-STD-883 (see 3.1 herein).

4.2 Screening. Screening shall be in accordance with method 5004 of MIL-STD-883, and shall be conducted on all devices prior to quality conformance inspection. The following additional criteria shall apply:

a. Burn-in test, method 1015 of MIL-STD-883.

(1) Test condition A or D using the circuit submitted with the certificate of compliance (see 3.5 herein).

(2) $T_A = +125^\circ\text{C}$, minimum.

b. Interim and final electrical test parameters shall be as specified in table II herein, except interim electrical parameter tests prior to burn-in are optional at the discretion of the manufacturer.

4.3 Quality conformance inspection. Quality conformance inspection shall be in accordance with method 5005 of MIL-STD-883 including groups A, B, C, and D inspections. The following additional criteria shall apply.

4.3.1 Group A inspection.

a. Tests shall be as specified in table II herein.

b. Subgroups 4, 5, and 6 in table I, method 5005 of MIL-STD-883 shall be omitted.

c. Subgroup 7 and 8 tests shall verify the truth table as specified on figure 2 herein.

4.3.2 Groups C and D inspections.

a. End-point electrical parameters shall be as specified in table II herein.

b. Steady-state life test conditions, method 1005 of MIL-STD-883.

(1) Test condition A or D using the circuit submitted with the certificate of compliance (see 3.5 herein).

(2) $T_A = +125^\circ\text{C}$, minimum.

(3) Test duration: 1,000 hours, except as permitted by method 1005 of MIL-STD-883.

STANDARDIZED MILITARY DRAWING DEFENSE ELECTRONICS SUPPLY CENTER DAYTON, OHIO 45444	SIZE A	5962-89553
	REVISION LEVEL	SHEET 9

DESC FORM 193A
SEP 87

* U. S. GOVERNMENT PRINTING OFFICE: 1988-550-547

TABLE II. Electrical test requirements.

MIL-STD-883 test requirements	Subgroups (per method 5005, table I)
Interim electrical parameters (method 5004)	---
Final electrical test parameters (method 5004)	1*, 2, 3, 7, 8, 9, 10, 11
Group A test requirements (method 5005)	1, 2, 3, 7, 8, 9, 10, 11
Group C and D end-point electrical parameters (method 5005)	1, 2, 3

* PDA applies to subgroup 1.

5. PACKAGING

5.1 Packaging requirements. The requirements for packaging shall be in accordance with MIL-M-38510.

6. NOTES

6.1 Intended use. Microcircuits conforming to this drawing are intended for use when military specifications do not exist and qualified military devices that will perform the required function are not available for OEM application. When a military specification exists and the product covered by this drawing has been qualified for listing on QPL-38510, the device specified herein will be inactivated and will not be used for new design. The QPL-38510 product shall be the preferred item for all applications.

6.2 Replaceability. Microcircuits covered by this drawing will replace the same generic device covered by a contractor-prepared specification or drawing.

6.3 Comments. Comments on this drawing should be directed to DESC-ECS, Dayton, Ohio 45444, or telephone 513-296-5375.

STANDARDIZED MILITARY DRAWING DEFENSE ELECTRONICS SUPPLY CENTER DAYTON, OHIO 45444	SIZE A	5962-89553
	REVISION LEVEL	SHEET 10

DESC FORM 193A
SEP 87

U. S. GOVERNMENT PRINTING OFFICE: 1988-550-547

6.4 Approved source of supply. An approved source of supply is listed herein. Additional sources will be added as they become available. The vendor listed herein has agreed to this drawing and a certificate of compliance (see 3.5 herein) has been submitted to DESC-ECS.

Military drawing part number	Vendor CAGE number	Vendor similar part number 1/
5962-8955301RX	01295	SNJ54AS640J
5962-8955301SX	01295	SNJ54AS640W
5962-89553012X	01295	SNJ54AS640FK

1/ Caution. Do not use this number for item acquisition. Items acquired to this number may not satisfy the performance requirements of this drawing.

Vendor CAGE number

01295

Vendor name and address

Texas Instruments, Incorporated
P.O. Box 60448
Midland, TX 79711-0448

STANDARDIZED MILITARY DRAWING DEFENSE ELECTRONICS SUPPLY CENTER DAYTON, OHIO 45444	SIZE A		5962-89553
		REVISION LEVEL	SHEET 11

DESC FORM 193A
SEP 87

★ U. S. GOVERNMENT PRINTING OFFICE: 1988-550-547