

Distributed Gate Thyristors ~ All types

www.DataSheet4U.com

Type	V_{DRM}/V_{RRM} Range (Note 3) (V)	T_q 200V/ μ s (μ s)	$I_{T,av}$ T_{hs} 55°C (A)	I_{TRM} (A) 50% Duty Cycle T_{SINK} 55°C			T_{SINK} 55°C			di/dt Rep/Non-Rep (A/ μ s)	I_{TRMS} 25°C (A)	I_T 25°C (A)	$I_{TSM(1)}$ $V_R \leq 60\%$ V_{RRM} T_j 125°C 10ms (Note 1) (A)	$I_{TSM(2)}$ $V_R \leq 10V$ T_j 125°C 10ms (Note 1) (A)
				Sine wave			Square wave 100 A/ μ sec							
				1 KHz	5 KHz	10 KHz	1 KHz	5 KHz	10 KHz					
R210CHx	200-1400	20-30	425	1200	1060	890	800	685	670	500/1000	870	690	4300	4700
R185CHx	200-1200	20-25	500	1500	1350	1200	1000	850	820	500/1000	1030	820	6000	6600
R216CHx	200-1200	20-30	560	1750	1550	1300	1180	1000	975	500/1000	1125	925	6300	6900
R180CHx	200-1000	12-20	810	2200	1700	1400	1500	1200	1050	1000/1500	1690	1260	8000	8800
R190CHx	200-1400	25-35	830	2600	2050	1650	1650	1450	1350	1000/1500	1715	1320	8500	9350
R200CHx	1200-2100*	60-75	880	2600	1900	1500	1700	1400	1200	1000/1500	1765	1455	7500	8250
R219CHx	200-1200	15-25	930	2700	2100	1650	1800	1500	1350	1000/1500	1895	1505	9000	9900
R220CHx	200-1200	20-30	959	3000	2300	1800	1950	1700	1500	1000/1500	1950	1550	9400	10800
R270CHx	200-800	10-20	990	3000	2500	2150	2000	1950	1900	1000/1500	2000	1628	11000	12000
R305CHx	1200-1800	60-70	1126	3400	2200	1600	2100	1500	1300	1000/1500	2268	1855	13500	15000
R325CHx	200-1400	25-40	1180	3600	2700	2000	2500	2000	1800	1000/1500	2398	1915	17000	18700
R350CHx	200-1200	20-25	1212	3800	2300	1800	2300	1700	1500	1000/1500	2496	1926	17600	19400
R355CHx	200-1200	20-30	1273	3800	2700	2100	2600	2000	1800	1000/1500	2600	2050	18000	19800
R395CHx	1200-2100*	65-75	1293	3900	2500	1900	2500	1900	1600	1000/1500	2594	2144	15500	17000
R400CHx	200-1200	25-35	1448	4600	3100	2300	2900	2300	2100	1000/1500	2943	2353	19500	21500
R600CHx	1600-2100†	50-70	2550	6400	4000	3000	4400	3300	3000	1000/1500	5087	4390	33800	37200
R800CHx	1200-1800	40-60	2700	7000	4100	3100	4700	3500	3000	1000/1500	5260	4560	35600	39000
R1200CHx	200-1200	20-30	3375	9900	6600	4700	6800	7500	8000	1000/1500	6860	5480	43900	48300
D315CHx	2100-3600	140-200	1065	3200	2350	1750	2100	1550	1300	1000/1500	2110	1800	12800	14100
D350CHx	2000-2600	80-120	1090	3250	2200	1650	2000	1400	1160	1000/1500	2177	1840	14500	15950
D390CHx	1800-2100†	45-70	1205	3800	2800	2100	2400	1900	1800	1000/1500	2426	1988	14800	16300
D405CHx	200-1800	40-65	1363	4900	3100	2500	2800	2300	2000	1000/1500	2749	2240	15500	17000
D450CHx	200-1200	10-20	1330	5000	3600	2600	2800	2850	2800	1000/1500	2690	2190	18200	20000

* V_{RRM} 1800 V Max.

† V_{DRM} 2500 V available on request

www.DataSheet4U.com

P _T (2) T _j 125°C 10ms (Note 1) (A ² s)	Typical Recovered Charge at 125°C, 50% Chord at I _r & dir/dt			I _{DRM} I _{RRM} @ T _j Max.	I _{GT} V _{GT}	V _{TM} at I _T at 125°C		V ₀ r at 125°C		R _{th} j-sink d.c & 180° sine 120° Rect.		Wt. (gm)	Mounting Force (Kgf)	Fig. No.	Type
	(μC)	(A)	(A/μs)			(V)	(A)	(V)	(mΩ)	(K/W)	(K/W)				
110 x 10 ³	41	550	40	60	200/3	2.70	1000	1.82	0.880	0.060	0.070	90	530/1000	1	R210C
218 x 10 ³	85	550	40	60	200/3	2.15	1000	1.51	0.640	0.060	0.070	90	530/1000	1	R185C
240 x 10 ³	85	550	40	60	200/3	1.85	1000	1.23	0.620	0.060	0.070	90	530/1000	1	R216C
387 x 10 ³	45	1000	60	70	300/3	2.52	1400	2.10	0.300	0.032	0.041	340	1000/2000	2	R180C
437 x 10 ³	110	1000	60	70	300/3	2.40	1400	1.90	0.357	0.032	0.041	340	1000/2000	2	R190C
340 x 10 ³	355	1000	60	70	300/3	2.12	1400	1.45	0.480	0.032	0.041	340	1000/2000	2	R200C
490 x 10 ³	85	1000	60	70	300/3	2.04	1400	1.55	0.350	0.032	0.041	340	1000/2000	2	R219C
580 x 10 ³	115	1000	60	70	300/3	1.96	1400	1.50	0.330	0.032	0.041	340	1000/2000	2	R220C
720 x 10 ³	40	1000	60	70	300/3	1.84	1400	1.35	0.350	0.032	0.041	340	1000/2000	2	R270C
1.13 x 10 ⁶	400	1000	60	150	300/3	2.30	2000	1.55	0.375	0.024	0.029	510	1900/2600	3	R305C
1.75 x 10 ⁶	170	1000	60	150	300/3	2.20	2000	1.60	0.300	0.024	0.029	510	1900/2600	3	R325C
1.88 x 10 ⁶	100	1000	60	150	300/3	2.18	2000	1.72	0.230	0.024	0.029	510	1900/2600	3	R350C
1.96 x 10 ⁶	135	1000	60	150	300/3	2.02	2000	1.55	0.236	0.024	0.029	510	1900/2600	3	R355C
1.45 x 10 ⁶	420	1000	60	150	300/3	1.90	2000	1.30	0.300	0.024	0.029	510	1900/2600	3	R395C
2.30 x 10 ⁶	130	1000	60	150	300/3	1.70	2000	1.30	0.200	0.024	0.029	510	1900/2600	3	R400C
6.92 x 10 ⁶	1100	4000	60	300	300/3	2.00	4000	1.30	0.175	0.011	0.012	1700	2700/4700	4	R600C
7.61 x 10 ⁶	700	4000	60	300	300/3	1.90	4000	1.25	0.163	0.011	0.012	1700	2700/4700	4	R800C
11.7 x 10 ⁶	225	4000	60	300	300/3	1.54	4000	1.22	0.08	0.011	0.012	1700	2700/4700	4	R1200C
994 x 10 ³	1350	1000	60	100	300/3	2.42	2000	1.39	0.514	0.022	0.024	510	1900/2600	3	D315C
1.27 x 10 ⁶	700	1000	60	100	300/3	2.40	2000	1.60	0.40	0.022	0.024	510	1900/2600	3	D350C
1.33 x 10 ⁶	540	1000	60	150	300/3	2.10	2000	1.44	0.330	0.022	0.024	510	1900/2600	3	D390C
1.45 x 10 ⁶	500	1000	60	150	300/3	1.80	2000	1.30	0.250	0.022	0.024	510	1900/2600	3	D405C
2.0 x 10 ⁶	75	1000	60	150	300/3	2.02	2000	1.45	0.285	0.022	0.024	510	1900/2600	3	D450C

1

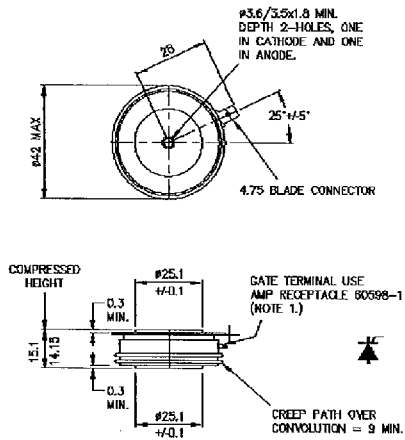

101A237

2

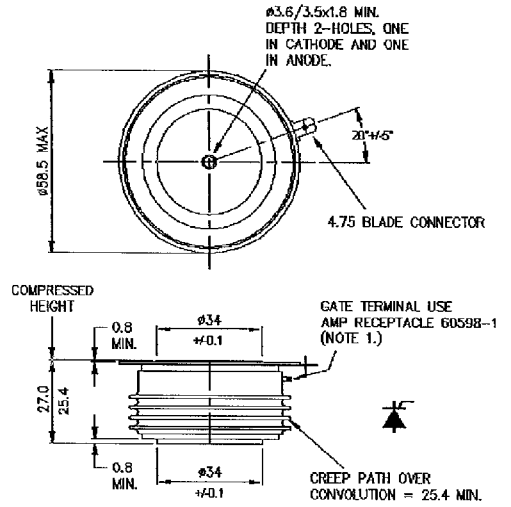

101A216

3

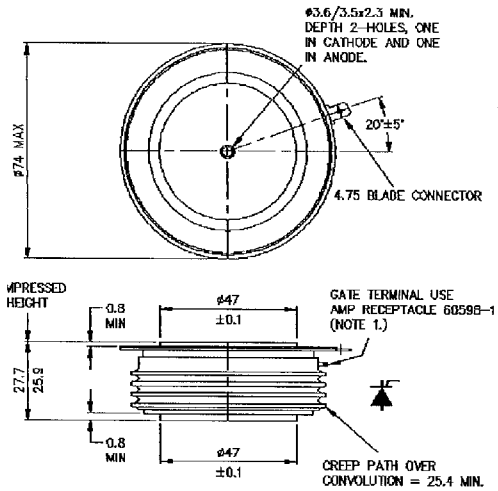

101A223

4

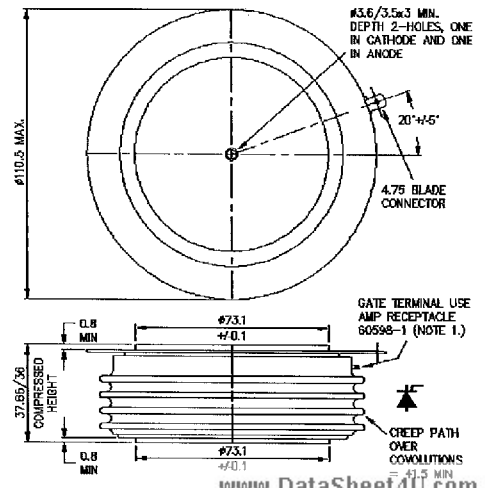

101A281

Westcode "D" and "R" series of fast switching thyristors have a regenerative interdigitated gate structure to ensure low switching losses and enhanced di/dt performance. Low reverse recovery charge values, combined with the low forward switching losses, make these devices particularly attractive in applications such as Induction Heating Inverters, D.C. Chopper Drives, Uninterruptable Power Supplies, etc.

Ordering

The full type number identifies voltage rating, dv/dt and turn-off time. An example would be an R216 series device with 1200 Volt repetitive forward and reverse rating and a turn-off time of 25µs with 200V/µsec commutating dv/dt.

R216CH	12	F	J	O
(1)	(2)	(3)	(4)	(5)

- (1) Type number selected from table
- (2) Voltage grade code from Table 1
- (3) dv/dt code from Table 2
- (4) Turn-off time code from Table 3
- (5) V_{RRM} (see below)

All types available with V_{RRM} ratings less than V_{DRM} ratings, for example where an anti-parallel diode is used. To identify these types a figure is inserted in space (5) of the thyristor code – see above.

A single digit represents V_{RRM} in 10% increments of the V_{DRM} selected.

Example:

R305CH18FW4 has a V_{DRM} of 1800 volts and V_{RRM} of 720 volts.

The lower limit of the V_{RRM} is 200 volts. An 'O' in position (5) indicates $V_{RRM} = V_{DRM}$.

Table 1. Voltage Code

Code Number	V_{DRM} and V_{RRM}	V_{RSM}	V_{DSM}
02	200	300	200
04	400	500	400
06	600	700	600
08	800	900	800
10	1000	1100	1000
12	1200	1300	1200
14	1400	1500	1400
16	1600	1700	1600
18	1800	1900	1800
20	2000	2100	2000
21	2100	2200	2100
22	2200	2300	2200
24	2400	2500	2400
26	2600	2700	2600
28	2800	2900	2800
30	3000	3100	3000
32	3200	3300	3200
34	3400	3500	3400
36	3600	3700	3600

Table 2. dv/dt Code

dv/dt (V/µsec)	Code
20	C
50	D
100	E
200	F

Table 3. Turn-off Time Code

Tq (µsec)	Code
10	N
12	M
15	L
20	K
25	J
30	H
35	G
40	2K
50	F
55	Y
60	2H
65	W
70	2G
75	E
100	D
120	4H
140	4G
160	8K
180	6H
200	2D

Turn-off times shown in Table 3 are measured at 125°C with re-applied dv/dt of 200V/µsec linear, and 50 volts reverse. Current pulse and di/dt are shown for recovered charge measurements.

Other combinations of dv/dt and turn-off time giving shorter or longer turn-off times can be supplied subject to discussion with Westcode Sales Department.

Notes

(1) $I_{TSM}(8.3msec) = I_{TSM}(10msec) \times 1.066$
 $I^2t(8.3msec) = I^2t(10msec) \times 0.943$

(2) V_o Threshold voltage } for conduction loss
 r Slope resistance } and heatsink calculations
 (Tj = 125°C)

(3) A blocking voltage derating factor of 0.13% per deg. C. is applicable for Tj below 25 deg. C.