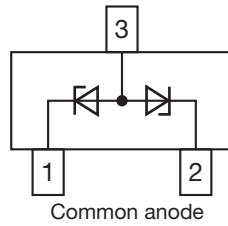


Small Signal Zener Diodes, Dual



FEATURES

- Dual silicon planar Zener diodes with common anode configurations
- Dual package provides for bidirectional or separate unidirectional configurations
- The dual configurations protect two separate lines with only one device
- Peak power: 40 W at 1 ms (bidirectional)
- For bidirectional operation, circuit connected to pins 1 and 2. For unidirectional operation, circuit connected to pins 1 and 3 or pins 2 and 3
- AEC-Q101 qualified
- Compliant to RoHS Directive 2002/95/EC and in accordance to WEEE 2002/96/EC


RoHS
COMPLIANT

PRIMARY CHARACTERISTICS		
PARAMETER	VALUE	UNIT
V_Z range nom.	27	V
Test current I_{ZT}	1	mA
V_Z specification	Pulse current	
Int. construction	Dual	

ORDERING INFORMATION			
DEVICE NAME	ORDERING CODE	TAPED UNITS PER REEL	MINIMUM ORDER QUANTITY
MMBZ27VDA-V	MMBZ27VDA-V-GS18	10 000 (8 mm tape on 13" reel)	10 000
MMBZ27VDA-V	MMBZ27VDA-V-GS08	3000 (8 mm tape on 7" reel)	15 000

PACKAGE				
PACKAGE NAME	WEIGHT	MOLDING COMPOUND FLAMMABILITY RATING	MOISTURE SENSITIVITY LEVEL	SOLDERING CONDITIONS
SOT-23	8.8 mg	UL 94 V-0	MSL level 1 (according J-STD-020)	260 °C/10 s at terminals

ABSOLUTE MAXIMUM RATINGS ($T_{amb} = 25\text{ °C}$, unless otherwise specified)				
PARAMETER	TEST CONDITION	SYMBOL	VALUE	UNIT
Peak power dissipation ⁽¹⁾		P_{PK}	40	W
Power dissipation on FR-5 board ⁽²⁾	$T_{amb} = 25\text{ °C}$, derate above 25 °C	P_{tot}	225	mW
			1.8	mW/K
Power dissipation on alumina substrate ⁽³⁾	$T_{amb} = 25\text{ °C}$, derate above 25 °C	P_{tot}	300	mW
			2.4	mW/K
Thermal resistance, junction to ambient air		R_{thJA}	556	K/W
Storage temperature range		T_j, T_{stg}	- 55 to + 150	°C

Notes

- (1) Nonrepetitive current pulse per figure 2 and derate above $T_{amb} = 25\text{ °C}$ per figure 3
 (2) FR-5 = 1" x 0.75" x 0.62"
 (3) Alumina = 0.4" x 0.3" x 0.024", 99.5 % alumina.

ELECTRICAL CHARACTERISTICS ($T_{amb} = 25\text{ }^{\circ}\text{C}$, unless otherwise specified)											
PART NUMBER	ZENER VOLTAGE RANGE ⁽¹⁾			TEST CURRENT	REVERSE VOLTAGE		MAX. REVERSE SURGE CURRENT	MAX. REVERSE VOLTAGE (CLAMPING VOLTAGE) ⁽²⁾	MAX. TEMPERATURE COEFFICIENT	MAX. FORWARD VOLTAGE	
	V_Z at I_{ZT1}			I_{ZT1}	V_R at I_R		I_{PP}	V_C at I_{RSM}	V_Z	V_F at I_F	
	V			mA	V	nA	A	V	mV/ $^{\circ}\text{C}$	V	mA
	MIN.	NOM.	MAX.		MAX.						
MMBZ27VDA-V	25.65	27	28.35	1	22	80	1	38	30	1.1	200

Notes

(1) V_Z measured at pulse test current I_{ZT} at an ambient temperature of $25\text{ }^{\circ}\text{C}$

(2) Surge current waveform per figure 2 and derate per figure 3

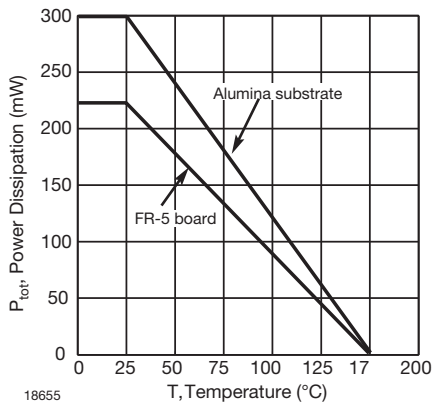
BASIC CHARACTERISTICS ($T_{amb} = 25\text{ }^{\circ}\text{C}$, unless otherwise specified)


Fig. 1 - Steady State Power Derating Curve

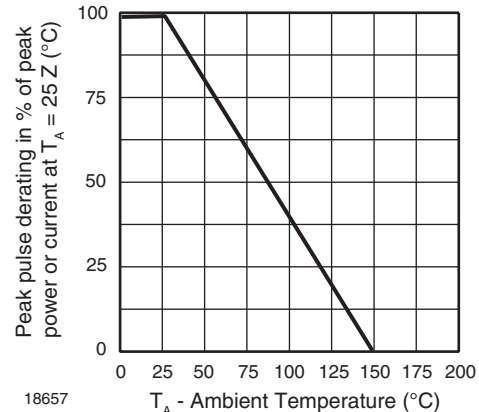


Fig. 3 - Pulse Derating Curve

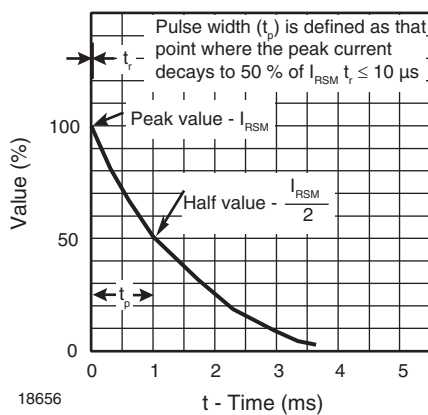
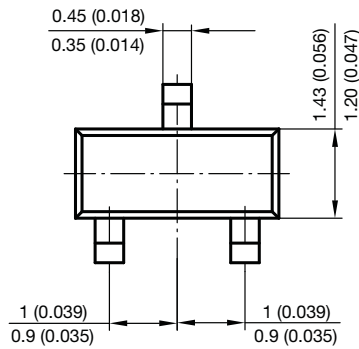
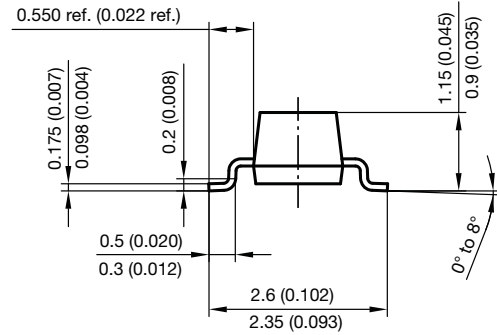
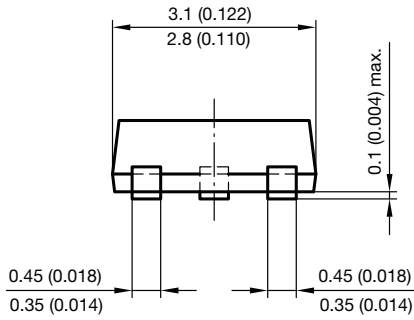


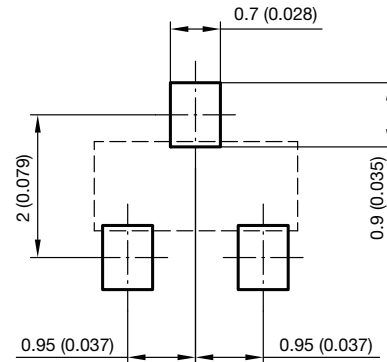
Fig. 2 - Pulse Waveform



PACKAGE DIMENSIONS in millimeters (inches): SOT-23



Foot print recommendation:



Document no.: 6.541-5014.01-4
 Rev. 8 - Date: 23.Sept.2009
 17418



Disclaimer

ALL PRODUCT, PRODUCT SPECIFICATIONS AND DATA ARE SUBJECT TO CHANGE WITHOUT NOTICE TO IMPROVE RELIABILITY, FUNCTION OR DESIGN OR OTHERWISE.

Vishay Intertechnology, Inc., its affiliates, agents, and employees, and all persons acting on its or their behalf (collectively, "Vishay"), disclaim any and all liability for any errors, inaccuracies or incompleteness contained in any datasheet or in any other disclosure relating to any product.

Vishay makes no warranty, representation or guarantee regarding the suitability of the products for any particular purpose or the continuing production of any product. To the maximum extent permitted by applicable law, Vishay disclaims (i) any and all liability arising out of the application or use of any product, (ii) any and all liability, including without limitation special, consequential or incidental damages, and (iii) any and all implied warranties, including warranties of fitness for particular purpose, non-infringement and merchantability.

Statements regarding the suitability of products for certain types of applications are based on Vishay's knowledge of typical requirements that are often placed on Vishay products in generic applications. Such statements are not binding statements about the suitability of products for a particular application. It is the customer's responsibility to validate that a particular product with the properties described in the product specification is suitable for use in a particular application. Parameters provided in datasheets and/or specifications may vary in different applications and performance may vary over time. All operating parameters, including typical parameters, must be validated for each customer application by the customer's technical experts. Product specifications do not expand or otherwise modify Vishay's terms and conditions of purchase, including but not limited to the warranty expressed therein.

Except as expressly indicated in writing, Vishay products are not designed for use in medical, life-saving, or life-sustaining applications or for any other application in which the failure of the Vishay product could result in personal injury or death. Customers using or selling Vishay products not expressly indicated for use in such applications do so at their own risk and agree to fully indemnify and hold Vishay and its distributors harmless from and against any and all claims, liabilities, expenses and damages arising or resulting in connection with such use or sale, including attorneys fees, even if such claim alleges that Vishay or its distributor was negligent regarding the design or manufacture of the part. Please contact authorized Vishay personnel to obtain written terms and conditions regarding products designed for such applications.

No license, express or implied, by estoppel or otherwise, to any intellectual property rights is granted by this document or by any conduct of Vishay. Product names and markings noted herein may be trademarks of their respective owners.

Material Category Policy

Vishay Intertechnology, Inc. hereby certifies that all its products that are identified as RoHS-Compliant fulfill the definitions and restrictions defined under Directive 2011/65/EU of The European Parliament and of the Council of June 8, 2011 on the restriction of the use of certain hazardous substances in electrical and electronic equipment (EEE) - recast, unless otherwise specified as non-compliant.

Please note that some Vishay documentation may still make reference to RoHS Directive 2002/95/EC. We confirm that all the products identified as being compliant to Directive 2002/95/EC conform to Directive 2011/65/EU.