

2SA1854

PNP Epitaxial Planar Silicon Transistor

20V/5A Switching Applications

Applications

- Strobes, power supplies, relay drivers, lamp drivers.

Features

- Adoption of FBET and MBIT processes.
- Large allowable collector dissipation.
- Low saturation voltage.
- Large current capacity.
- Fast switching speed.
- Usage of radial taping to meet automatic mounting.

Absolute Maximum Ratings at Ta = 25°C

			unit
Collector-to-Base Voltage	V _{CB0}	-25	V
Collector-to-Emitter Voltage	V _{CE0}	-20	V
Emitter-to-Base Voltage	V _{EBO}	-5	V
Collector Current	I _C	-5	A
Collector Current (Pulse)	I _{CP}	-8	A
Base Current	I _B	-0.5	A
Collector Dissipation	P _C	1.5	W
Junction Temperature	T _j	150	°C
Storage Temperature	T _{stg}	-55 to +150	°C

Electrical Characteristics at Ta = 25°C

			min	typ	max	unit
Collector Cutoff Current	I _{CBO}	V _{CB} = -20V, I _E = 0			-500	nA
Emitter Cutoff Current	I _{EBO}	V _{EB} = -4V, I _C = 0			-500	nA
DC Current Gain	h _{FE} (1)	V _{CE} = -2V, I _C = -500mA	100*		400*	
	h _{FE} (2)	V _{CE} = -2V, I _C = -4A	60			
Gain Bandwidth Product	f _T	V _{CE} = -5V, I _C = -200mA		320		MHz
Output Capacitance	C _{ob}	V _{CB} = -10V, f = 1MHz		60		pF

Continued on next page.

*: The 2SA1854 is classified by 500mA h_{FE} as follows:

100 R 200	140 S 280	200 T 400
-----------	-----------	-----------

Switching Time Test Circuit

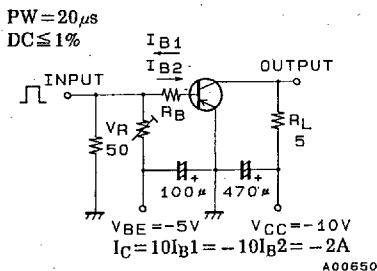

Unit (Resistance : Ω, Capacitance : F)

Package Dimensions 2084B

(unit:mm)

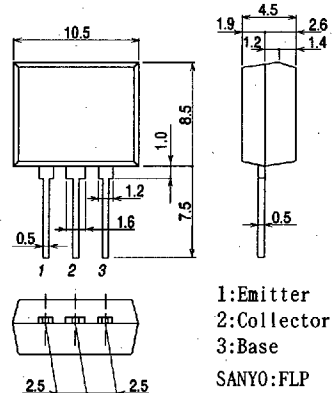

1:Emitter
2:Collector
3:Base
SANYO:FLP

Continued from preceding page.

			min	typ	max	unit
C-E Saturation Voltage	$V_{CE(sat)}$	$I_C = -3A, I_B = -60mA$		-250	-500	mV
B-E Saturation Voltage	$V_{BE(sat)}$	$I_C = -3A, I_B = -60mA$		-1.0	-1.3	V
C-B Breakdown Voltage	$V_{(BR)CBO}$	$I_C = -10\mu A, I_E = 0$	-25			V
C-E Breakdown Voltage	$V_{(BR)CEO}$	$I_C = -1mA, R_{BE} = \infty$	-20			V
E-B Breakdown Voltage	$V_{(BR)EBO}$	$I_E = -10\mu A, I_C = 0$	-5			V
Turn ON Time	t_{on}	See specified Test Circuit.		40		ns
Storage Time	t_{stg}	"		200		ns
Fall Time	t_f	"		10		ns

