



Helping Customers Innovate, Improve & Grow

Search

Go

[XOs](#) > [CO-487](#)

CO-487 Sinewave Crystal Oscillators



Features:

- Frequencies from 4 MHz to 500 MHz
- Miniature Hybrid Design
- 16 Pin Double DIP or 16 Pin Flatpack
- +13 dBm output available

SPECIFICATIONS																					
Series	CO-487: Miniature Hybrid																				
Frequency	4 MHz to 500 MHz																				
Output	Standard: 0.5 Vrms/50Ω (+7 dBm) Option R: 1 Vrms/50Ω (+13 dBm) High level option: 1 watt (+30 dBm) available in 2" x 3" x 0.75" package																				
Supply	+15 Vdc ±5% (Any supply in 12-24 Vdc range optional; supply less than +15 Vdc subject to reduced output level)																				
Accuracy (at 25°C)	CO-487A: ±50 ppm CO-487C: ±25 ppm CO-487D: ±15 ppm CO-487B: ±10 ppm *CO-487E: ±1 ppm *Set via external capacitor.																				
Temperature Stability	STANDARD: 0°C to +70°C: ±25 ppm Option 1: -55°C to +85°C: ±50 ppm Option 2: -55°C to +125°C: ±50 ppm (not available in CO-287W) Option 3: 0°C to +50°C: ±3 ppm (not available in CO-484, CO-487, CO-287W) Option 5: 0°C to +50°C: ±5 ppm Option 6: 0°C to +50°C: ±10 ppm																				
Aging Rate (typical after 30 days)	3 ppm first year <2 ppm per year thereafter																				
Phase Noise (typical 4-100 MHz)	<table border="1"> <thead> <tr> <th>Offset from Carrier</th> <th>Standard</th> <th>Option L1*</th> <th>Option L2**</th> </tr> </thead> <tbody> <tr> <td>100 Hz</td> <td>-100 dBc/Hz</td> <td>-115 dBc/Hz</td> <td>-120 dBc/Hz</td> </tr> <tr> <td>1 kHz</td> <td>-125 dBc/Hz</td> <td>-140 dBc/Hz</td> <td>-145 dBc/Hz</td> </tr> <tr> <td>10 kHz</td> <td>-140 dBc/Hz</td> <td>-150 dBc/Hz</td> <td>-160 dBc/Hz</td> </tr> <tr> <td>50 kHz</td> <td>-145 dBc/Hz</td> <td>-155 dBc/Hz</td> <td>-160 dBc/Hz</td> </tr> </tbody> </table> <p>Noise degrades by 6 dB per octave above 100 MHz *L1 Option is not available in CO-281, CO-484, CO-487 **L2 Option is available only in CO-233FW and is limited to 200 MHz: above 100 MHz, output of CO-233FWL2 is restricted to +7 dBm.</p>	Offset from Carrier	Standard	Option L1*	Option L2**	100 Hz	-100 dBc/Hz	-115 dBc/Hz	-120 dBc/Hz	1 kHz	-125 dBc/Hz	-140 dBc/Hz	-145 dBc/Hz	10 kHz	-140 dBc/Hz	-150 dBc/Hz	-160 dBc/Hz	50 kHz	-145 dBc/Hz	-155 dBc/Hz	-160 dBc/Hz
Offset from Carrier	Standard	Option L1*	Option L2**																		
100 Hz	-100 dBc/Hz	-115 dBc/Hz	-120 dBc/Hz																		
1 kHz	-125 dBc/Hz	-140 dBc/Hz	-145 dBc/Hz																		
10 kHz	-140 dBc/Hz	-150 dBc/Hz	-160 dBc/Hz																		
50 kHz	-145 dBc/Hz	-155 dBc/Hz	-160 dBc/Hz																		

[top of page](#)

How to Order Hybrid XO's - CO-400 Series

(Note: Not all combinations possible. See above for appropriate options.)

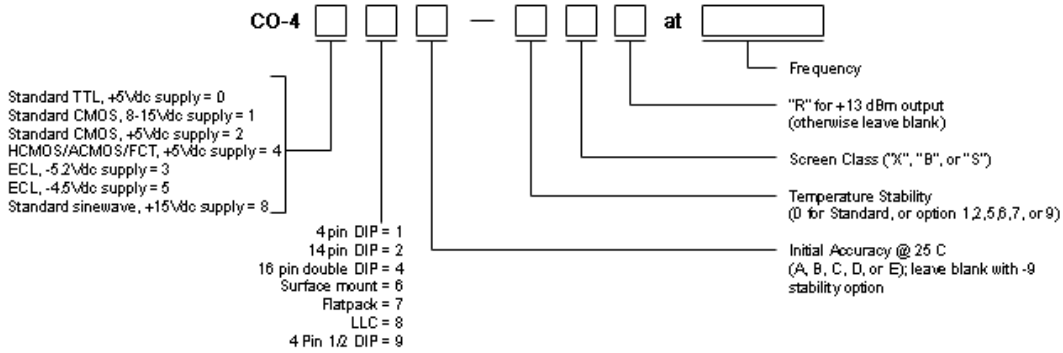

SCREEN TESTING OF ABOVE MODELS					
SCREEN TEST	MIL-STD-883 METHOD	Options			
		Standard CLASS X	CLASS D	CLASS B	CLASS S
Stabilization Bake (150°C)	—	X	X	X	Class S screen test requirements include 24 hour additional bake-out, 80 hour additional burn-in, thermal shock, PIND test and radiographic inspection in addition to Class B Screening. Has major cost impact.
Seal Test (Gross and Fine)	1014, Cond A2	X	X	X	
Temperature Cycling (Thermal Shock)	1010, Cond B		X	X	
Burn-in, operating 160 hours @125°C	—		X	X	
Acceleration (5000g in Y ₁ axis)	2001, Cond A			X	

[top of page](#)

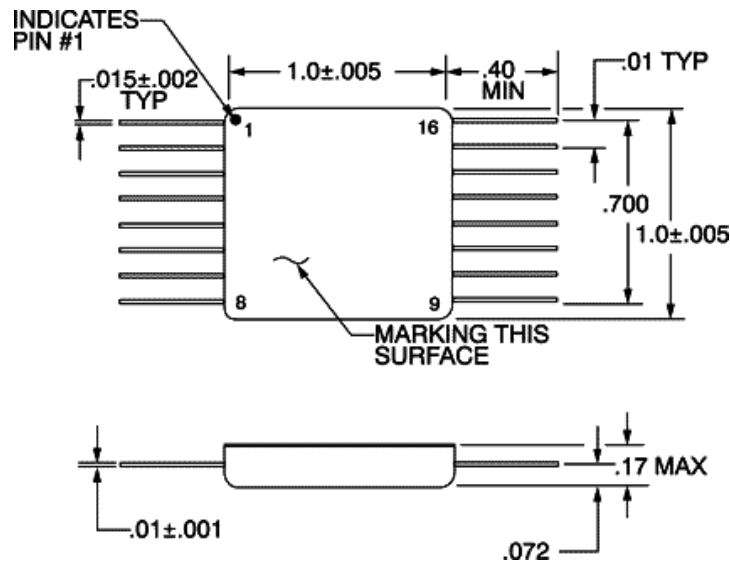

Dimension in inches

Pinouts

*Pin	Function
8	0V, Case
9	Output
11	**
16	Supply

*Unlisted pins may be used internally
** \leq 200 MHz: no connection
>200 Mhz: 0V, Case
E Option, connect 5-30 pf capacitor from pin 5 to pin 8.

[top of page](#)

Copyright © 1997-2009 by Vectron International, Inc., [A Dover Company](#).
Vectron International's [Terms and Conditions](#).
The most recent change to this page occurred 02/11/2009