

isc Silicon NPN Power Transistor

2SC3353

DESCRIPTION

- Collector-Emitter Sustaining Voltage-
: $V_{CEO(SUS)} = 500V(\text{Min.})$
- Low Collector Saturation Voltage
: $V_{CE(sat)} = 1.0V(\text{Max.}) @ I_C = 3A$
- High Speed Switching

APPLICATIONS

- Designed for high speed switching applications.

ABSOLUTE MAXIMUM RATINGS ($T_a = 25^\circ C$)

SYMBOL	PARAMETER	VALUE	UNIT
V_{CBO}	Collector-Base Voltage	800	V
V_{CEO}	Collector-Emitter Voltage	500	V
V_{EBO}	Emitter-Base Voltage	8	V
I_C	Collector Current-Continuous	5	A
I_{CM}	Collector Current-Peak	10	A
I_B	Base Current-Continuous	3	A
P_C	Collector Power Dissipation @ $T_a = 25^\circ C$	2	W
	Collector Power Dissipation @ $T_C = 25^\circ C$	40	
T_j	Junction Temperature	150	$^\circ C$
T_{stg}	Storage Temperature Range	-55~150	$^\circ C$

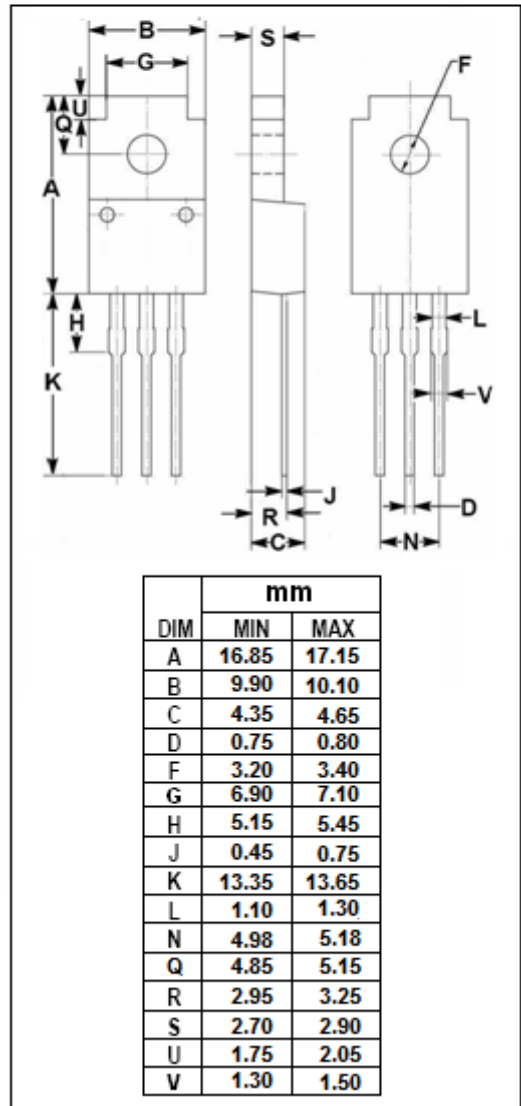
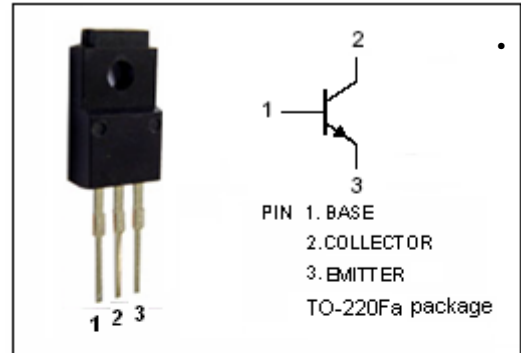

isc Silicon NPN Power Transistor

2SC3353

ELECTRICAL CHARACTERISTICS

 $T_C=25^{\circ}\text{C}$ unless otherwise specified

SYMBOL	PARAMETER	CONDITIONS	MIN	TYP.	MAX	UNIT
$V_{CEO(SUS)}$	Collector-Emitter Sustaining Voltage	$I_C=0.2\text{A}$; $L=25\text{mH}$	500			V
$V_{CE(sat)}$	Collector-Emitter Saturation Voltage	$I_C=3\text{A}$; $I_B=0.6\text{A}$			1.0	V
$V_{BE(sat)}$	Base-Emitter Saturation Voltage	$I_C=3\text{A}$; $I_B=0.6\text{A}$			1.5	V
I_{CBO}	Collector Cutoff Current	$V_{CB}=800\text{V}$; $I_E=0$			0.1	mA
I_{EBO}	Emitter Cutoff Current	$V_{EB}=5\text{V}$; $I_C=0$			0.1	mA
h_{FE-1}	DC Current Gain	$I_C=0.1\text{A}$; $V_{CE}=5\text{V}$	15			
h_{FE-2}	DC Current Gain	$I_C=3\text{A}$; $V_{CE}=5\text{V}$	8			
f_T	Current-Gain—Bandwidth Product	$I_C=0.5\text{A}$; $V_{CE}=10\text{V}$		3		MHz

Switching Times; Resistive Load

t_{on}	Turn-on Time	$I_C=3\text{A}$; $I_{B1}=-I_{B2}=0.6\text{A}$; $V_{CC}=200\text{V}$			1.0	μs
t_s	Storage Time				3.0	μs
t_f	Fall Time				1.0	μs