

A Compact Low-cost RF Technology Demonstrator for Design and Development of Digital FDMA PMR Transceiver Products

Features

- Low cost dPMR/PMR446 technology demonstrator
- Meets EN 301 166 (dPMR) and EN 300 296 (PMR446)
- 446.0 to 446.2 MHz at 500mW Tx operation
- Sensitive switched bandwidth limiter-discriminator receiver
- On-board 19.2MHz reference and PLL/VCOs for 446MHz operation
- DE6181 (CMX7141) Interfacing and PE0002 control via PC
- Compact footprint:
RF area = 45mm x 50mm
- Functional test scripts available

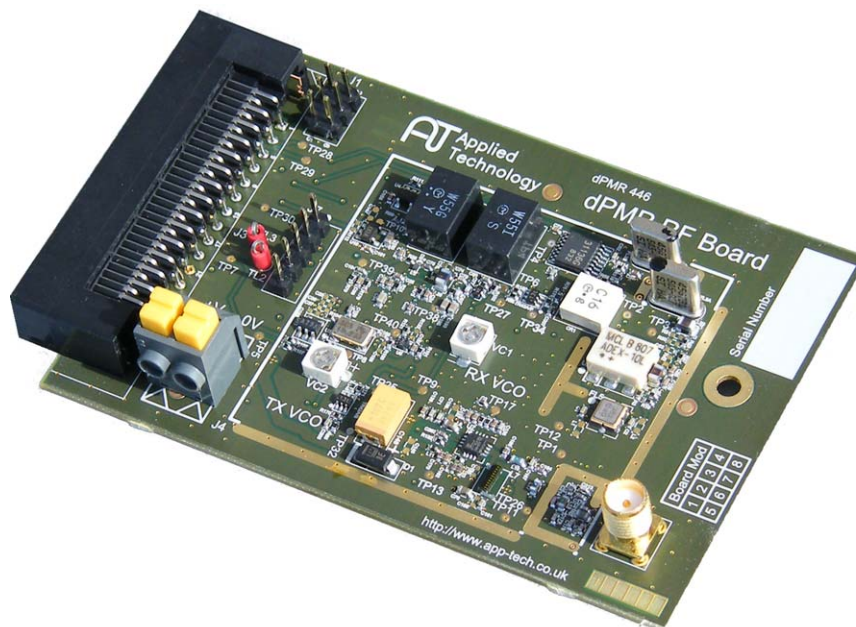

Brief Description

The ATB010 is a small, low cost, PCB-based RF technology demonstrator aimed at speeding manufacturers' design and development of dPMR/PMR446 transceiver products. The board is designed as a plug-in to the CML *DE6181 demonstration kit. Along with a *PE0002 host controller a full RF transceiver can be assembled to offer a variety of voice and data options configurable via Function Image™ and control scripts.

All the necessary RF circuits are provided on the ATB010 PCB: receiver and transmitter VCOs, a 500mW RF power amplifier, harmonic filter, antenna switching, LNA, RF to IF mixer and limiter discriminator IF processing. The RF performance is designed to be compliant with EN 301 166 (6.25kHz dPMR) and EN 300 296 (12.5kHz PMR446). The DE6181 demonstration kit is a flexible platform that can provide both digital (dPMR) and analogue (PMR446) functionality.

The design is production-engineered for low bill of materials cost, with a minimum number of component types and values and uses only low-cost off-the-shelf components. The design uses a single 3.6V supply, e.g. 3 AAA cells or a Li-ion battery.

***DE6181**: Demonstration Kit for CML's CMX618 and CMX7141.

***PE0002**: Evaluation Kit - a global interface system for use with evaluation kits for CML's new generation ICs, including *FirmASIC*®-based products.

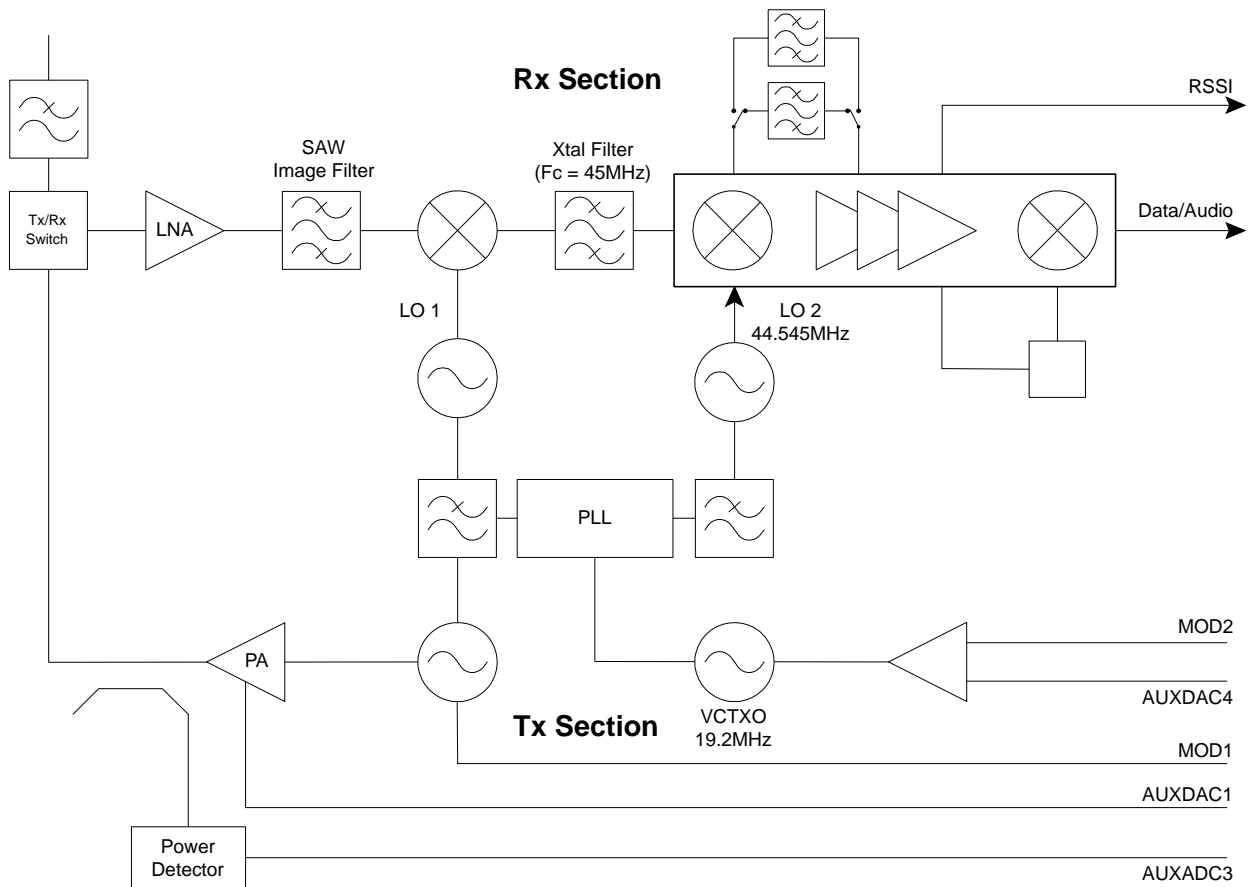

The ATB010 functional block diagram

On-board Circuits

Front end LNA

A UHF discrete bipolar LNA. Along with subsequent stages, this is biased to achieve the demanding receiver intermodulation requirements.

SAW image filter

This filter (after the LNA) is an 8MHz bandwidth 446MHz SAW filter providing rejection of image and other spurious responses.

Mixer

After approximately 2dB of attenuation, a diode ring mixer is used to convert from 446MHz to the 1st IF of 45MHz. This requires approximately +4dBm LO drive.

Post mixer IF amplifier

An isolation amplifier that provides a good match at its output to the crystal filter. The input from the mixer is matched by a Pi network giving a good 50Ohm match.

IF crystal filter

A 4-pole, fundamental mode, 2 x UM1 packaged crystal filter with a passband of approximately +/-3.75kHz. Correct matching of the filters is necessary to achieving optimum performance.

Post filter amplifier

A resistive termination to the FM IF IC input. It also provides a high input impedance to the crystal filter output matching network. The gain provided overcomes the losses in not matching to the high impedance of the FM IF IC input.

Receiver local oscillators

VCOs are provided for 1st and 2nd LOs of the receiver, both locked using a dual PLL synthesiser IC. The 1st LO in particular requires excellent performance in order for the receiver to meet the required adjacent channel rejection at 6.25kHz offset.

The 2nd local oscillator at 44.545MHz is provided using a conventional common collector Collpits circuit. The PLL reference used is 5kHz in this case.

Reference oscillator

A 1.5ppm 19.2MHz VCTCXO is provided on the PCB. Note that for transmit operation, both the VCO and the reference frequencies are modulated.

2nd IF/demodulation

The IF signal from the post crystal filter amplifier is presented to the input of the FM/IF demodulation IC. This IC and surrounding circuitry provide a number of functions:

- A mixer from the 1st IF to 455kHz (the 2nd IF)
- Further channel filtering using inexpensive ceramic filters which are selectable for 12.5kHz or 6.25kHz operation)
- A limiter-discriminator demodulator using a ceramic resonator
- Switched loading on the discriminator to provide a consistent output across both operating channel bandwidths
- An RSSI output that can be monitored by a CMX7141 AUX ADC.

Transmitter

The transmit VCO operates at the final operating frequency and uses the same oscillator architecture as the receive VCO.

A separate varactor diode is used for applying modulation from MOD1. The VCO is locked using the RF PLL, which requires reprogramming between receiver and transmitter operation. A common loop filter is used for both the Tx and Rx VCOs.

The transmitter provides at least +28dBm over the range 440 to 450 MHz.

The CMX7141 RAM DAC output is connected to the PA control line via a diode and transistor to provide sufficient current to the PA control pins.

Tx/Rx switch

Circuitry is provided to implement a classical series-shunt Tx/Rx switch using PIN diodes after a lumped quarter wave section. The diodes are activated in transmit via the TxEN signal from the CMX7141. An additional diode is provided to protect the LNA from extremely strong signals (e.g. a nearby transceiver). This branch of the switch then goes the receiver LNA input.

Harmonic filter

A low-loss low pass filter with traps centred at the 2nd and 3rd Tx harmonics. This filter is common to the transmitter and receiver paths and is connected between the Tx/Rx switch and the antenna connector J2.

Power detector

An RF power detector operates on the forward branch of the discrete directional coupler. The output from the detector can be monitored using AUX ADC3 on the CMX7141 of the EV6181. Alternatively it can be monitored via an on-board test point.

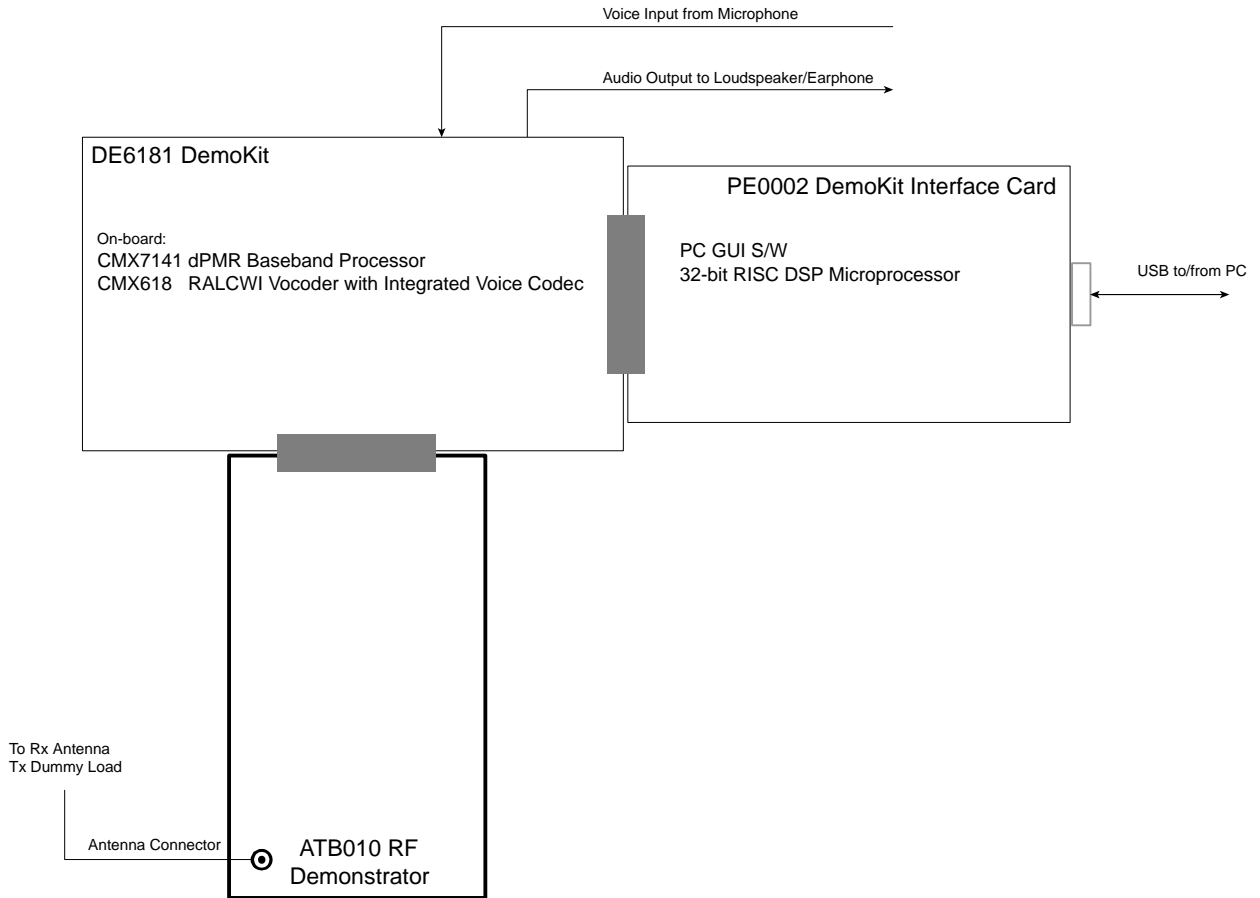

The ATB010 RF Demonstrator configured as a complete dPMR transceiver

Example Performance Specification

Frequency range	446.0 to 446.2 MHz
Channel spacing	6.25 or 12.5 kHz
Transmitter output power	500mW
Modulation	4-Level FSK and analogue FM
Sensitivity (BER = 1%)	-118dBm (typ)
Adjacent channel power	>-60dB
Adjacent channel rejection	>50dB
Power supply	3.6V (nom)

Application Concerns

The ATB010 itself is a demonstration PCB and has not been approved to any product standards. The user is advised not to radiate signals using the ATB010 without complying with the local regulatory requirements, for example obtaining a test and development licence from the appropriate national body.

Note: Tests can be performed using the ATB010 using cable connection and dummy loads without the need for radiated signals. In the laboratory environment leakage from cables is often sufficient for the sensitive ATB010 receiver to operate.





This product is designed and manufactured by Applied Technology, a member of the CML Microsystems Plc group of companies.

For more information, please contact:

- www.app-tech.co.uk/Glossary/DPMR_DMR.htm
- enquiries@app-tech.co.uk
- Telephone: +44 (0) 1749 881130
- Fax: +44 (0) 1749 881133

Handling precautions: This product includes input protection, however, precautions should be taken to prevent device damage from electro-static discharge. CML does not assume any responsibility for the use of any circuitry described. No IPR or circuit patent licences are implied. CML reserves the right at any time without notice to change the said circuitry and this product specification. CML has a policy of testing every product shipped using calibrated test equipment to ensure compliance with this product specification. Specific testing of all circuit parameters is not necessarily performed.

 CML Microcircuits (UK) Ltd COMMUNICATION SEMICONDUCTORS	 CML Microcircuits (USA) Inc. COMMUNICATION SEMICONDUCTORS	 CML Microcircuits (Singapore) Pte Ltd COMMUNICATION SEMICONDUCTORS <div style="display: flex; justify-content: space-around;">SingaporeChina</div>	
Tel: +44 (0)1621 875500 Fax: +44 (0)1621 875600 Sales: sales@cmlmicro.com Tech Support: techsupport@cmlmicro.com	Tel: +1 336 744 5050 800 638 5577 Fax: +1 336 744 5054 Sales: us.sales@cmlmicro.com Tech Support: us.techsupport@cmlmicro.com	Tel: +65 67450426 Fax: +65 67452917 Sales: sg.sales@cmlmicro.com Tech Support: sg.techsupport@cmlmicro.com	Tel: +86 21 6317 4107 +86 21 6317 8916 Fax: +86 21 6317 0243 Sales: cn.sales@cmlmicro.com.cn Tech Support: sg.techsupport@cmlmicro.com
- www.cmlmicro.com -			