



7N65A

Power MOSFET

7A, 650V N-CHANNEL POWER MOSFET

DESCRIPTION

The UTC **7N65A** is a high voltage N-Channel enhancement mode power field effect transistors designed to have minimize on-state resistance, superior switching performance and withstand high energy pulse in the avalanche and commutation mode. This power MOSFET is well suited for high efficiency switch mode power supply.

FEATURES

- * $R_{DS(ON)} = 1.4\Omega @ V_{GS} = 10V$
- * Ultra low gate charge (typical 28 nC)
- * Low reverse transfer Capacitance (C_{RSS} = typical 12 pF)
- * Fast switching capability
- * Avalanche energy tested
- * Improved dv/dt capability, high ruggedness

SYMBOL

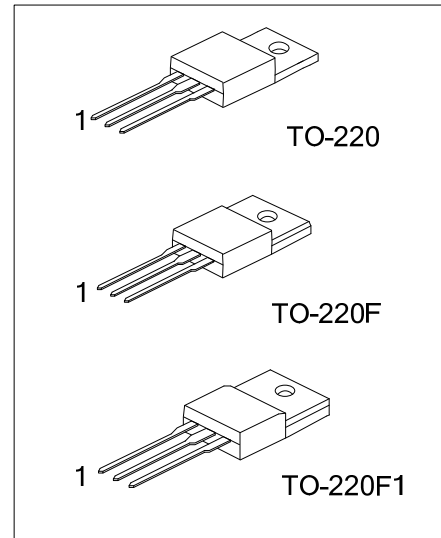
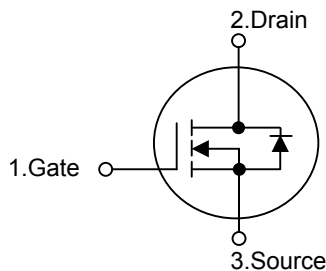

ORDERING INFORMATION

Ordering Number		Package	Pin Assignment			Packing
Lead Free	Halogen Free		1	2	3	
7N65AL-TA3-T	7N65AG-TA3-T	TO-220	G	D	S	Tube
7N65AL-TF1-T	7N65AG-TF1-T	TO-220F1	G	D	S	Tube
7N65AL-TF3-T	7N65AG-TF3-T	TO-220F	G	D	S	Tube

Note: Pin Assignment: G: Gate D: Drain S: Source

<p>7N65AL-TA3-T</p> <p>(1)Packing Type</p> <p>(2)Package Type</p> <p>(3)Lead Free</p>	<p>(1) T: Tube</p> <p>(2) TA3: TO-220, TF1: TO220-F1, TF3: TO-220F</p> <p>(3) G: Halogen Free, L: Lead Free</p>
---	---

■ ABSOLUTE MAXIMUM RATINGS ($T_C = 25^\circ\text{C}$, unless otherwise specified)

PARAMETER		SYMBOL	RATINGS	UNIT
Drain-Source Voltage		V_{DSS}	650	V
Gate-Source Voltage		V_{GSS}	± 30	V
Avalanche Current (Note 2)		I_{AR}	7	A
Continuous Drain Current		I_D	7	A
Pulsed Drain Current (Note 2)		I_{DM}	28	A
Avalanche Energy	Single Pulsed (Note 3)	E_{AS}	330	mJ
	Repetitive (Note 2)	E_{AR}	7.5	mJ
Power Dissipation	TO-220	P_D	65	W
	TO-220F/TO-220F1		30	W
Junction Temperature		T_J	+150	$^\circ\text{C}$
Storage Temperature		T_{STG}	-55 ~ +150	$^\circ\text{C}$

Notes: 1. Absolute maximum ratings are those values beyond which the device could be permanently damaged.

Absolute maximum ratings are stress ratings only and functional device operation is not implied.

2. Repetitive Rating : Pulse width limited by $T_{J(MAX)}$

3. $L = 12.05\text{mH}$, $I_{AS} = 7.4\text{A}$, $V_{DD} = 50\text{V}$, $R_G = 27\ \Omega$, Starting $T_J = 25^\circ\text{C}$

■ THERMAL DATA

PARAMETER		SYMBOL	RATINGS	UNIT
Junction to Ambient	TO-220	θ_{JA}	83.3	$^\circ\text{C/W}$
	TO-220F/TO-220F1		62.5	
Junction to Case	TO-220	θ_{JC}	1.92	$^\circ\text{C/W}$
	TO-220F/TO-220F1		4.16	

■ ELECTRICAL CHARACTERISTICS ($T_C=25^\circ\text{C}$, unless otherwise specified)

PARAMETER	SYMBOL	TEST CONDITIONS	MIN	TYP	MAX	UNIT
OFF CHARACTERISTICS						
Drain-Source Breakdown Voltage	BV_{DSS}	$V_{GS} = 0V, I_D = 250\mu A$	650			V
Drain-Source Leakage Current	I_{DSS}	$V_{DS} = 650V, V_{GS} = 0V$			10	μA
Gate-Source Leakage Current	Forward	$V_{GS} = 30V, V_{DS} = 0V$			100	nA
	Reverse		$V_{GS} = -30V, V_{DS} = 0V$		-100	nA
ON CHARACTERISTICS						
Gate Threshold Voltage	$V_{GS(TH)}$	$V_{DS} = V_{GS}, I_D = 250\mu A$	2.0		4.0	V
Static Drain-Source On-State Resistance	$R_{DS(ON)}$	$V_{GS} = 10V, I_D = 3.5A$ (Note 4)		1.05	1.4	Ω
DYNAMIC CHARACTERISTICS						
Input Capacitance	C_{ISS}	$V_{DS}=25V, V_{GS}=0V, f=1.0\text{ MHz}$		950	1430	pF
Output Capacitance	C_{OSS}			85	130	pF
Reverse Transfer Capacitance	C_{RSS}			12	18	pF
SWITCHING CHARACTERISTICS						
Turn-On Delay Time	$t_{D(ON)}$	$V_{DD}=325V, I_D = 7A,$ $R_G = 25\Omega$ (Note 1, 2)		16		ns
Turn-On Rise Time	t_R			60		ns
Turn-Off Delay Time	$t_{D(OFF)}$			80		ns
Turn-Off Fall Time	t_F			65		ns
Total Gate Charge	Q_G	$V_{DS}=520V, I_D=7A,$ $V_{GS}=10V$ (Note 1, 2)		28	42	nC
Gate-Source Charge	Q_{GS}			5.5	8.3	nC
Gate-Drain Charge	Q_{GD}			11	17	nC
DRAIN-SOURCE DIODE CHARACTERISTICS AND MAXIMUM RATINGS						
Drain-Source Diode Forward Voltage	V_{SD}	$V_{GS} = 0V, I_S = 7A$			1.4	V
Maximum Continuous Drain-Source Diode Forward Current	I_S				7	A
Maximum Pulsed Drain-Source Diode Forward Current	I_{SM}				28	A
Reverse Recovery Time	t_{rr}	$V_{GS} = 0V, I_S = 7A,$		365		ns
Reverse Recovery Charge	Q_{RR}	$di_F / dt = 100A/\mu s$ (Note 1)		4.23		μC

Notes: 1. Pulse Test: Pulse width $\leq 300\mu s$, Duty cycle $\leq 2\%$

2. Essentially independent of operating temperature

■ TEST CIRCUITS AND WAVEFORMS

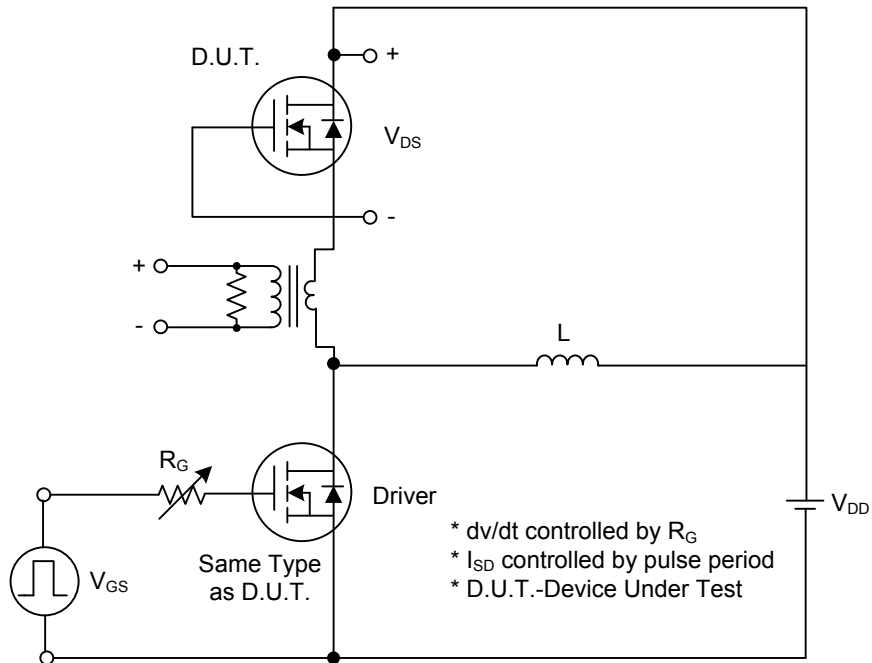

Peak Diode Recovery dv/dt Test Circuit

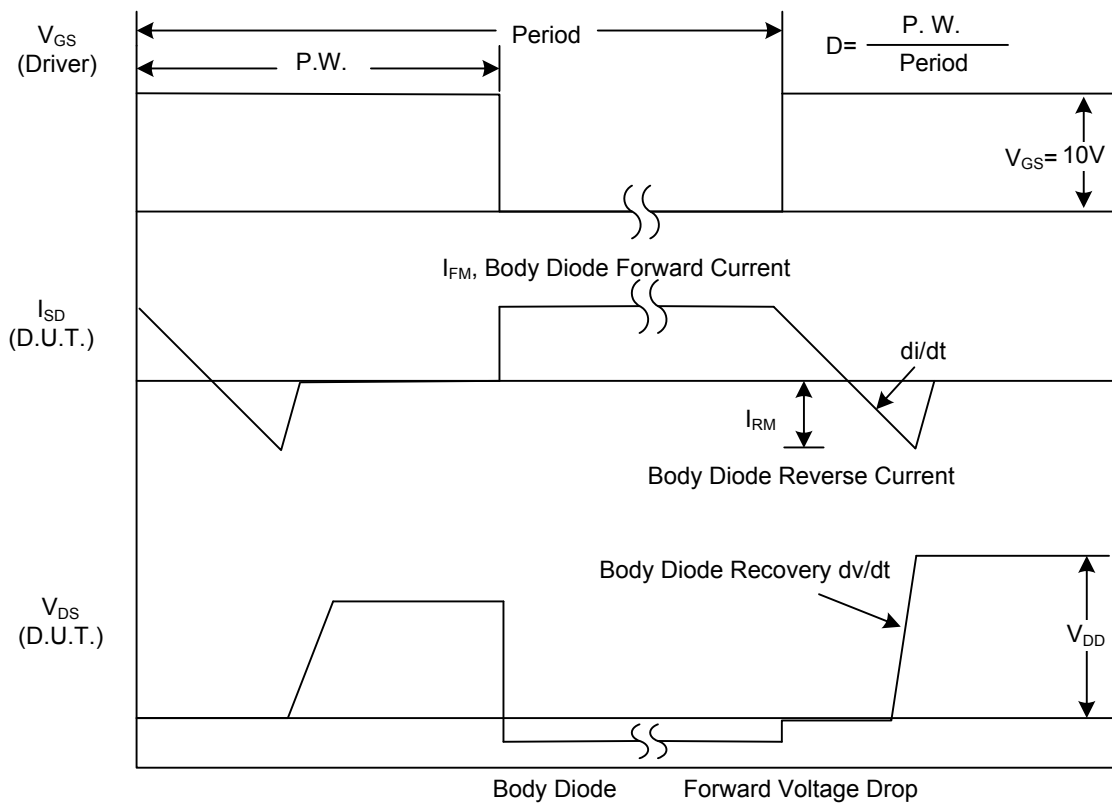

Peak Diode Recovery dv/dt Waveforms

■ TEST CIRCUITS AND WAVEFORMS (Cont.)

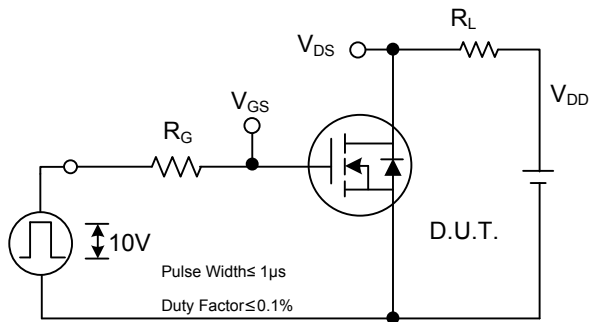

Switching Test Circuit

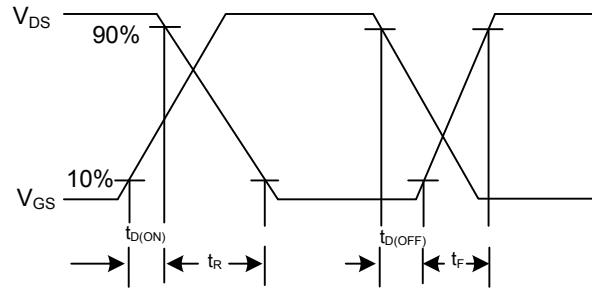

Switching Waveforms

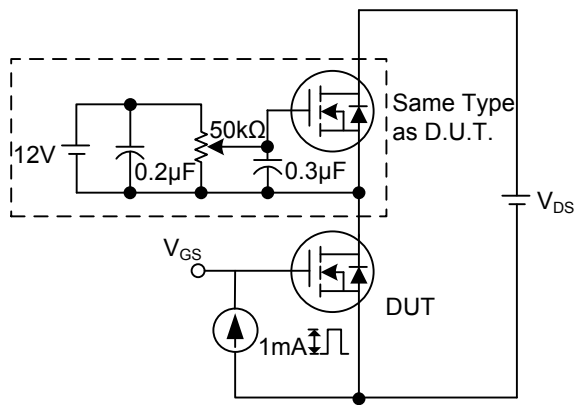

Gate Charge Test Circuit

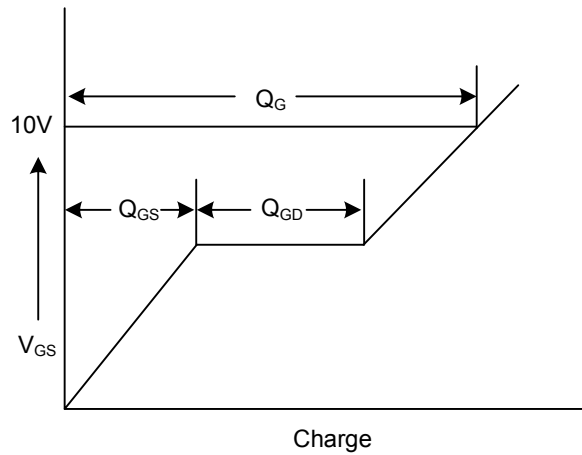

Gate Charge Waveform

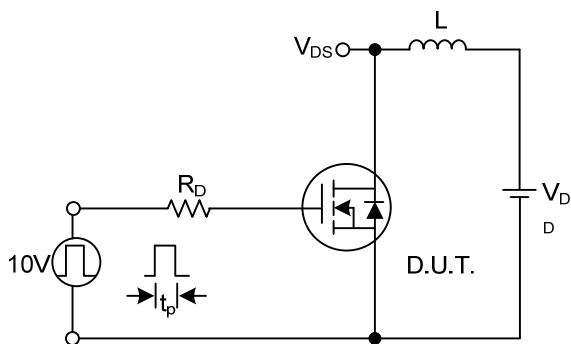

Unclamped Inductive Switching Test Circuit

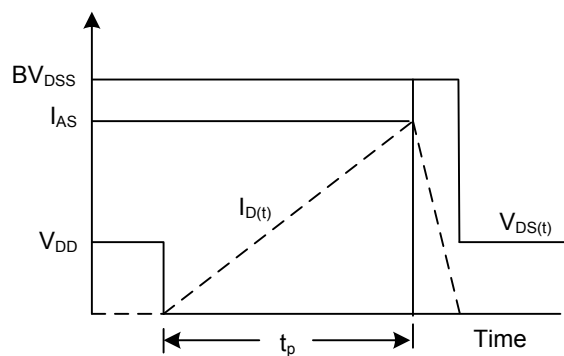

Unclamped Inductive Switching Waveforms

TYPICAL CHARACTERISTICS

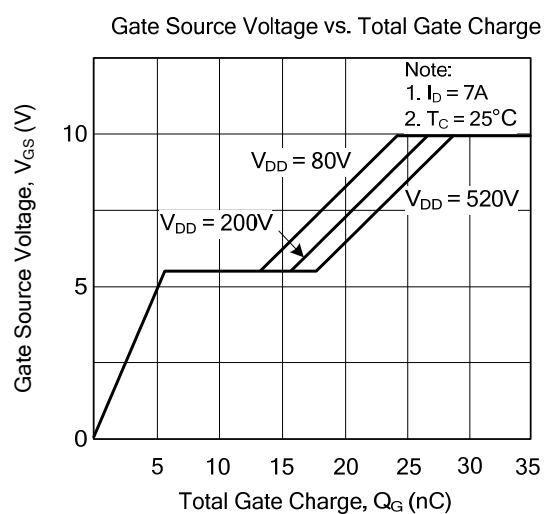
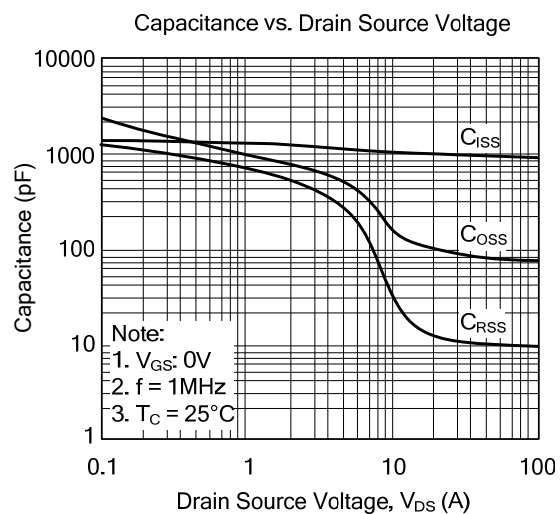
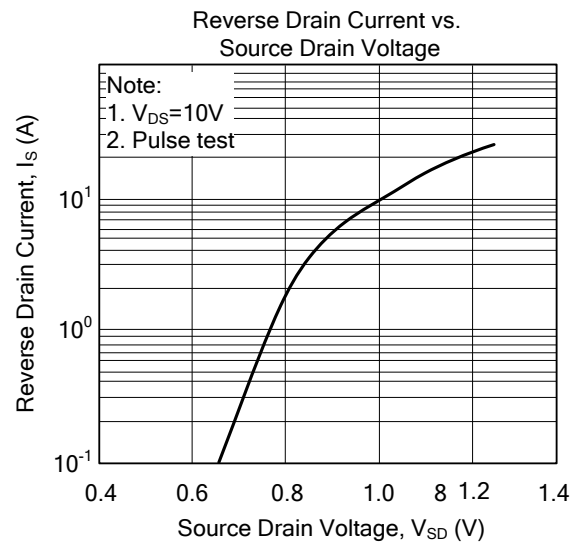
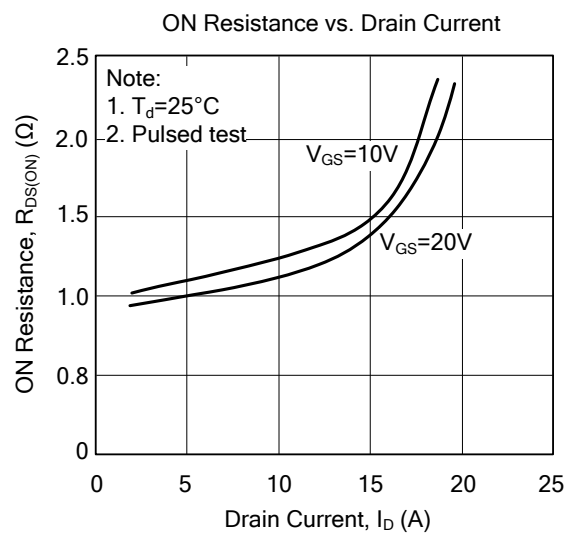
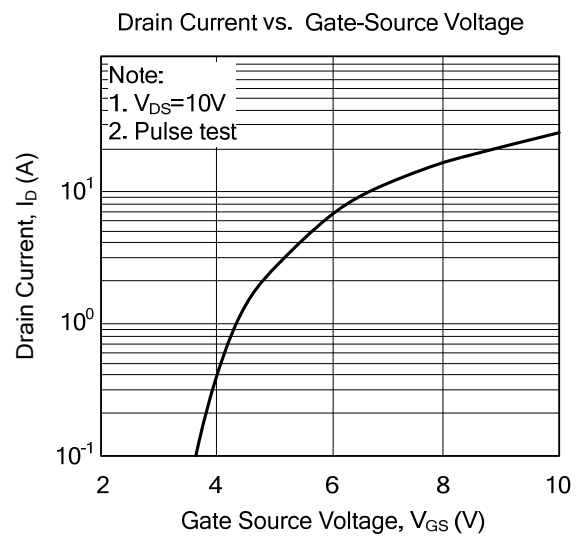
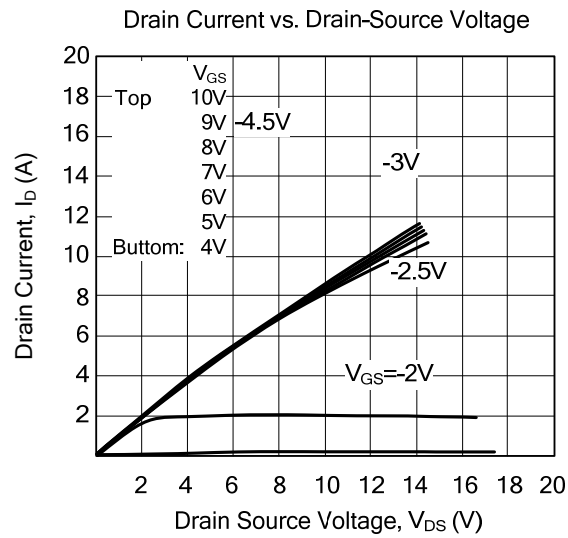

■ TYPICAL CHARACTERISTICS (Cont.)

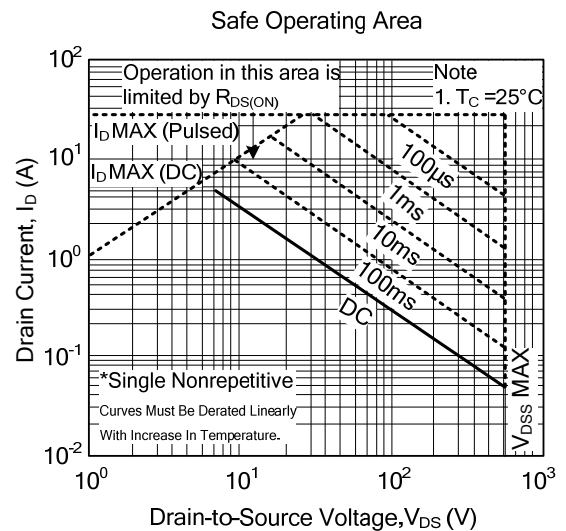
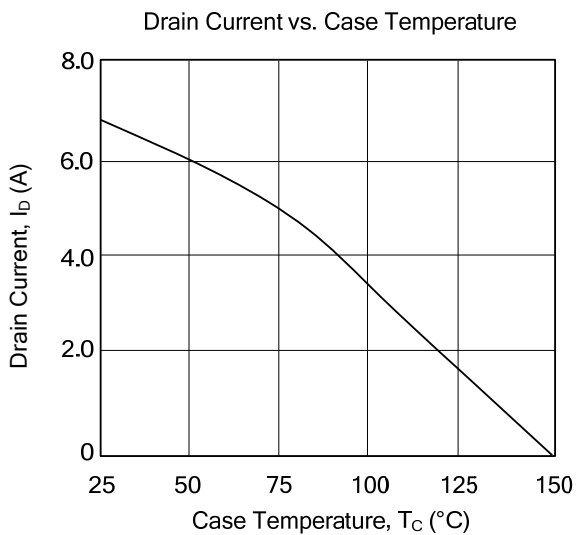
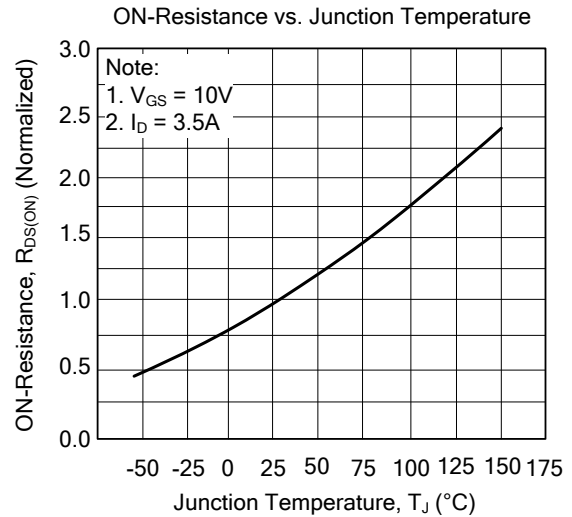
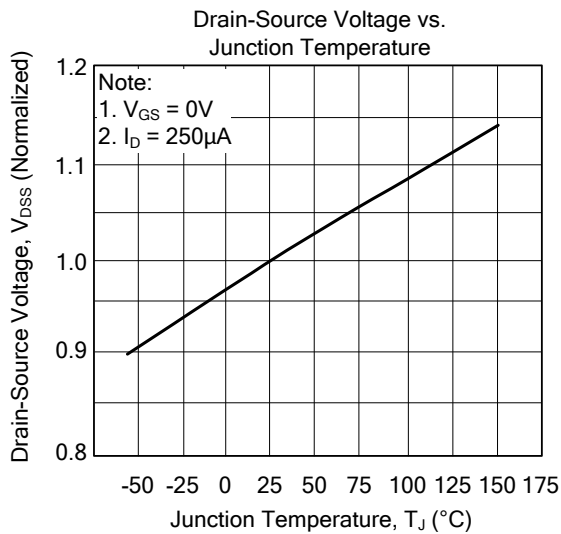

UTC assumes no responsibility for equipment failures that result from using products at values that exceed, even momentarily, rated values (such as maximum ratings, operating condition ranges, or other parameters) listed in products specifications of any and all UTC products described or contained herein. UTC products are not designed for use in life support appliances, devices or systems where malfunction of these products can be reasonably expected to result in personal injury. Reproduction in whole or in part is prohibited without the prior written consent of the copyright owner. The information presented in this document does not form part of any quotation or contract, is believed to be accurate and reliable and may be changed without notice.