



Holtek 32-bit Microcontroller with ARM® Cortex™-M3 Core

# HT32F1755/HT32F1765/HT32F2755 Datasheet

Revision: V1.00 Date: August 13, 2012

[www.holtek.com](http://www.holtek.com)

## Table of Contents

<b>1 General Description</b> .....	<b>6</b>
<b>2 Features</b> .....	<b>7</b>
Core .....	7
On-chip Memory .....	7
Flash Memory Controller .....	8
Reset Control Unit .....	8
Clock Control Unit.....	8
Power Management.....	9
Analog to Digital Converter.....	9
Analog Operational Amplifier/Comparator .....	9
I/O Ports.....	10
PWM Generation and Capture Timers – GPTM .....	10
Motor Control Timer – MCTM .....	11
Basic Function Timer – BFTM .....	11
Watchdog Timer.....	12
Real Time Clock.....	12
Inter-integrated Circuit – I <sup>2</sup> C .....	13
Serial Peripheral Interface – SPI .....	13
Universal Synchronous Asynchronous Receiver Transmitter – USART .....	14
Smart Card Interface – SCI .....	14
Peripheral Direct Memory Access – PDMA .....	15
Universal Serial Bus Device Controller – USB .....	15
CMOS Sensor Interface – CSIF (HT32F2755 only) .....	16
Debug Support.....	16
Package and Operation Temperature.....	16
<b>3 Overview</b> .....	<b>17</b>
Device Information .....	17
Block Diagram .....	18
Memory Map.....	19
Clock Structure .....	20
Pin Assignment.....	21

<b>4 Electrical Characteristics .....</b>	<b>28</b>
Absolute Maximum Ratings .....	28
Recommended DC Characteristics .....	28
On-Chip LDO Voltage Regulator Characteristics .....	28
Power Consumption .....	29
Reset and Supply Monitor Characteristics .....	29
External Clock Characteristics .....	30
Internal Clock Characteristics .....	31
PLL Characteristics .....	31
Memory Characteristics .....	31
I/O Port Characteristics .....	32
ADC Characteristics .....	33
Operation Amplifier/Comparator Characteristics .....	35
GPTM/MCTM Characteristics .....	35
I <sup>2</sup> C Characteristics .....	36
SPI Characteristics .....	37
CSIF Characteristics .....	38
USB Characteristics .....	39
<b>5 Package Information .....</b>	<b>41</b>
48-pin LQFP (7mm×7mm) Outline Dimensions .....	41
64-pin LQFP (7mm×7mm) Outline Dimensions .....	43
100-pin LQFP (14mm×14mm) Outline Dimensions .....	44

## List of Tables

Table 1. HT32F1755/1765/2755 Series Features and Peripheral List.....	17
Table 2. HT32F1755/1765/2755 Pin Descriptions .....	24
Table 3. Absolute Maximum Ratings.....	28
Table 4. Recommended DC Operating Conditions .....	28
Table 5. LDO Characteristics .....	28
Table 6. Power Consumption Characteristics .....	29
Table 7. LVD/BOD Characteristics .....	29
Table 8. High Speed External Clock (HSE) Characteristics.....	30
Table 9. Low Speed External Clock (LSE) Characteristics .....	30
Table 10. High Speed Internal Clock (HSI) Characteristics .....	31
Table 11. Low Speed Internal Clock (LSI) Characteristics .....	31
Table 12. PLL Characteristics .....	31
Table 13. Flash Memory Characteristics.....	31
Table 14. I/O Port Characteristics .....	32
Table 15. ADC Characteristics .....	33
Table 16. OPA/CMP Characteristics .....	35
Table 17. GPTM/MCTM Characteristics .....	35
Table 18. I <sup>2</sup> C Characteristics.....	36
Table 19. SPI Characteristics.....	37
Table 20. CSIF Characteristics .....	38
Table 21. USB DC Electrical Characteristics .....	39
Table 22. USB AC Electrical Characteristics.....	40

## List of Figures

Figure 1. HT32F1755/1765/2755 Block Diagram .....	18
Figure 2. HT32F1755/1765/2755 Memory Map.....	19
Figure 3. HT32F1755/1765/2755 Clock Structure .....	20
Figure 4. HT32F1755/1765/2755 48-LQFP Pin Assignment .....	21
Figure 5. HT32F1755/1765/2755 64-LQFP Pin Assignment .....	22
Figure 6. HT32F1755/1765/2755 100-LQFP Pin Assignment .....	23
Figure 7. ADC Sampling Network Model .....	34
Figure 8. I <sup>2</sup> C Timing Diagrams .....	36
Figure 9. SPI Timing Diagrams – SPI Master Mode .....	37
Figure 10. SPI Timing Diagrams – SPI Slave Mode and CPHA=1 .....	38
Figure 11. USB Signal Rise Time and Fall time and Cross-Point Voltage ( $V_{CRS}$ ) Definition.....	40

# 1 General Description

The Holtek HT32F1755/1765/2755 devices are high performance and low power consumption 32-bit microcontrollers based around an ARM® Cortex™-M3 processor core. The Cortex™-M3 is a next-generation processor core which is tightly coupled with Nested Vectored Interrupt Controller (NVIC), SysTick timer, and including advanced debug support.

The HT32F1755/1765/2755 devices operate at a frequency of up to 72MHz with a Flash accelerator to obtain maximum efficiency. It provides 128KB of embedded Flash memory for code/data storage and up to 64KB of embedded SRAM memory for system operation and application program usage. A variety of peripherals, such as ADC, I<sup>2</sup>C, USART, SPI, PDMA, GPTM, MCTM, SCI, CSIF, USB2.0 FS, SWJ-DP (Serial Wire and JTAG Debug Port), etc., are also implemented in the device series. Several power saving modes provide the flexibility for maximum optimisation between wakeup latency and power consumption, an especially important consideration in low power applications.

The above features ensure that the HT32F1755/1765/2755 devices are suitable for use in a wide range of applications, especially in areas such as white goods application control, power monitors, alarm systems, consumer products, handheld equipment, data logging applications, motor control, fingerprint recognition and so on.



## 2 Features

### Core

- 32-bit ARM® Cortex™-M3 processor core
- Up to 72MHz operation frequency
- 1.25 DMIPS/MHz (Dhrystone 2.1)
- Single-cycle multiplication and hardware division
- Integrated Nested Vectored Interrupt Controller (NVIC)
- 24-bit SysTick timer

The Cortex™-M3 processor is a general-purpose 32-bit processor core especially suitable for products requiring high performance and low power consumption microcontrollers. It offers many new features such as a Thumb-2 instruction set, hardware divider, low latency interrupt response time, atomic bit-banding access and multiple buses for simultaneous accesses. The Cortex™-M3 processor is based on the ARMv7 architecture and supports both Thumb and Thumb-2 instruction sets.

### On-chip Memory

- 128KB on-chip Flash memory for instruction/data and options storage
- up to 64KB on-chip SRAM
- Supports multiple boot modes

The ARM® Cortex™-M3 processor is structured using a Harvard architecture which uses separate busses to fetch instructions and load/store data. The instruction code and data are both located in the same memory address space but in different address ranges. The maximum address range of the Cortex™-M3 is 4GB due to its 32-bit bus address width. Additionally, a pre-defined memory map is provided by the Cortex™-M3 processor to reduce the software complexity of repeated implementation for different device vendors. However, some regions are used by the ARM® Cortex™-M3 system peripherals. Refer to the ARM® Cortex™-M3 Technical Reference Manual for more information. The Figure 2. shows the memory map of the HT32F1755/1765/2755 series of devices, including Code, SRAM, peripheral, and other pre-defined regions.

## Flash Memory Controller

- Flash accelerator for maximum efficiency
- 32-bit word programming with In System Programming Interface (ISP) and In Application Programming (IAP)
- Flash protection capability to prevent illegal access

The Flash Memory Controller, FMC, provides all the necessary functions and pre-fetch buffer for the embedded on-chip Flash Memory. Since the access speed of the Flash Memory is slower than the CPU, a wide access interface with a pre-fetch buffer is provided for the Flash Memory in order to reduce the CPU waiting time which will cause CPU instruction execution delays. Flash Memory word program/page erase functions are also provided.

## Reset Control Unit

- Supply supervisor:
  - Power-on Reset – POR
  - Brown-out Detector – BOD
  - Programmable Low Voltage Detector – LVD

The Reset Control Unit (RSTCU) has three kinds of reset, the power on reset, system reset and an APB unit reset. The power on reset, known as a cold reset, resets the full system during power up. A system reset resets the processor core and peripheral IP components with the exception of the SWJ-DP controller. The resets can be triggered by an external signal, internal events and the reset generators.

## Clock Control Unit

- External 4 to 16MHz crystal oscillator
- External 32,768Hz crystal oscillator
- Internal 8MHz RC oscillator trimmed to  $\pm 2\%$  accuracy at 3.3V operating voltage and 25°C operating temperature
- Internal 32kHz RC oscillator
- Integrated system clock PLL
- Independent clock gating bits for peripheral clock sources

The Clock Control unit, CKCU, provides a range of oscillator and clock functions. These include a High Speed Internal RC oscillator (HSI), a High Speed External crystal oscillator (HSE), a Low Speed Internal RC oscillator (LSI), a Low Speed External crystal oscillator (LSE), a Phase Lock Loop (PLL), a HSE clock monitor, clock prescalers, clock multiplexers and clock gating circuitry. The clocks of the AHB, APB and Cortex™-M3 are derived from the system clock (CK\_SYS) which can come from the HSI, HSE or PLL. The Watchdog Timer and Real Time Clock (RTC) use either the LSI or LSE as their clock source. The maximum operating frequency of the system core clock (CK\_AHB) can be up to 72MHz.



## Power Management

- Single 3.3V power supply: 2.7V to 3.6V
- Integrated 1.8V LDO regulator for core and peripheral power supply
- $V_{BAT}$  battery power supply for RTC and backup registers
- Three power domains: 3.3V, 1.8V and Backup
- Four power saving modes: Sleep, Deep-Sleep1, Deep-Sleep2, Power-Down

The Power consumption can be regarded as one of the most important issues for many embedded system applications. Accordingly the Power Control Unit, PWRCU, in these devices provides many types of power saving modes such as Sleep, Deep-Sleep1, Deep-Sleep2 and Power-Down mode. These operating modes reduce the power consumption and allow the application to achieve the best trade-off between the conflicting demands of CPU operating time, speed and power consumption.

## Analog to Digital Converter

- 12-bit SAR ADC engine
- Up to 1Msps conversion rate – 1 $\mu$ s at 56MHz, 1.17 $\mu$ s at 72MHz
- 8 external analog input channels
- Supply voltage range: 2.7V ~ 3.6V
- Conversion range:  $V_{REF+} \sim V_{REF-}$

A 12-bit multi-channel ADC is integrated in the device. There are a total of 10 multiplexed channels, which include 8 external channels on which the external analog signals can be measured, and 2 internal channels. If the input voltage is required to remain within a specific threshold window, an Analog Watchdog function will monitor and detect these signals. An interrupt will then be generated to inform the device that the input voltage is not within the preset threshold levels. There are three conversion modes to convert an analog signal to digital data. The ADC can be operated in one shot, continuous and discontinuous conversion modes.

## Analog Operational Amplifier/Comparator

- Two Operational Amplifiers or Comparator functions which are software configurable
- Supply voltage range: 2.7V ~ 3.6V

Two Operational Amplifiers/Comparators (OPA/CMP) are implemented within the devices. They can be configured either as Operational Amplifiers or as Analog Comparators. When configured as comparators, they are capable of generating interrupts to the NVIC.

## I/O Ports

- Up to 80 GPIOs
- Port A, B, C, D, E are mapped as 16 external interrupts – EXTI
- Almost all I/O pins are 5V-tolerant except for pins shared with analog inputs

There are up to 80 General Purpose I/O pins, (GPIO), named PA0 ~ PA15 to PE0 ~ PE15 for the implementation of logic input/output functions. Each of the GPIO ports has a series of related control and configuration registers to maximise flexibility and to meet the requirements of a wide range of applications.

The GPIO ports are pin-shared with other alternative functions to obtain maximum functional flexibility on the package pins. The GPIO pins can be used as alternative functional pins by configuring the corresponding registers regardless of the input or output pins.

The external interrupts on the GPIO pins of the device have related control and configuration registers in the External Interrupt Control Unit, EXTI.

## PWM Generation and Capture Timers – GPTM

- Two 16-bit General-Purpose Timers – GPTM
- Up to 4-channel PWM Compare Output or Input Capture function for each GPTM
- External trigger input

The General-Purpose Timers, known as GPTM0 and GPTM1, consist of one 16-bit up/down-counter, four 16-bit Capture/Compare Registers (CCRs), one 16-bit Counter-Reload Register (CRR) and several control/status registers. They can be used for a variety of purposes including general time measurement, input signal pulse width measurement, output waveform generation such as single pulse generation, or PWM output generation. The GPTM supports an Encoder Interface using a decoder with two inputs.

## Motor Control Timer – MCTM

- Single 16-bit up, down, up/down auto-reload counter
- 16-bit programmable prescaler allowing dividing the counter clock frequency by any factor between 1 and 65536
- Input Capture function
- Compare Match Output
- PWM waveform generation with Edge and Centre-aligned Modes
- Single Pulse Mode Output
- Complementary Outputs with programmable dead-time insertion
- Encoder interface controller with two inputs using quadrature decoder
- Support 3-phase motor control and hall sensor interface
- Brake input to force the timer's output signals into a reset or fixed condition

The Motor Control Timer consists of a single 16-bit up/down counter, four 16-bit CCRs (Capture/Compare Registers), single one 16-bit counter-reload register (CRR), single 8-bit repetition counter and several control/status registers. It can be used for a variety of purposes including measuring the pulse widths of input signals or generating output waveforms such as compare match outputs, PWM outputs or complementary PWM outputs with dead-time insertion. The MCTM supports an Encoder interface controller to an incremental encoder with two inputs. The MCTM is capable of offering full functional support for motor control, hall sensor interfacing and brake input.

## Basic Function Timer – BFTM

- Two 32-bit compare/match count-up counters – no I/O control features
- One shot mode – counting stops after a match condition
- Repetitive mode – restart counter after a match condition

The Basic Function Timer is a simple count-up 32-bit counter designed to measure time intervals and generate a one shot or repetitive interrupts. The BFTM operates in two functional modes, repetitive or one shot mode. In the repetitive mode the BFTM restarts the counter when a compare match event occurs. The BFTM also supports a one shot mode which forces the counter to stop counting when a compare match event occurs.

## Watchdog Timer

- 12-bit down counter with 3-bit prescaler
- Interrupt or reset event for the system
- Programmable watchdog timer window function
- Registers write protection function

The Watchdog Timer is a hardware timing circuit that can be used to detect system failures due to software malfunctions. It includes a 12-bit count-down counter, a prescaler, a WDT counter value register, a WDT delta value register, interrupt related circuits, WDT operation control circuitry and a WDT protection mechanism. The Watchdog Timer can be operated in an interrupt mode or a reset mode. The Watchdog Timer will generate an interrupt or a reset when the counter counts down and reaches a zero value. If the software does not reload the counter value before a Watchdog Timer underflow occurs, an interrupt or a reset will be generated when the counter underflows. In addition, an interrupt or reset is also generated if the software reloads the counter when the counter value is greater than or equal to the WDT delta value. This means the counter must be reloaded within a limited timing window using a specific method. The Watchdog Timer counter can be stopped while the processor is in the debug mode. There is a register write protect function which can be enabled to prevent it from changing the Watchdog Timer configuration unexpectedly.

## Real Time Clock

- 32-bit up-counter with a programmable prescaler
- Alarm function
- Interrupt and Wake-up event

The Real Time Clock, RTC, circuitry includes the APB interface, a 32-bit count-up counter, a control register, a prescaler, a compare register and a status register. Most of the RTC circuits are located in the Backup Domain except for the APB interface. The APB interface is located in the  $V_{DD18}$  power domain. Therefore, it is necessary to be isolated from the ISO signal that comes from the power control unit when the  $V_{DD18}$  power domain is powered off, that is when the device enters the Power-Down mode. The RTC counter is used as a wakeup timer to generate a system resume signal from the Power-Down mode.

## Inter-integrated Circuit – I<sup>2</sup>C

- Support both master and slave mode with a frequency of up to 1MHz
- Provide an arbitration function and clock synchronization
- Supports 7-bit and 10-bit addressing mode and general call addressing
- Supports slave multi-addressing mode with maskable address

The I<sup>2</sup>C Module is an internal circuit allowing communication with an external I<sup>2</sup>C interface which is an industry standard two line serial interface used for connection to external hardware. These two serial lines are known as a serial data line, SDA, and a serial clock line, SCL. The I<sup>2</sup>C module provides three data transfer rates: (1). 100kHz in the Standard mode, (2). 400kHz in the Fast mode and, (3). 1MHz in the Fast mode plus. The SCL period generation register is used to setup different kinds of duty cycle implementation for the SCL pulse.

The SDA line which is connected directly to the I<sup>2</sup>C bus is a bi-directional data line between the master and slave devices and is used for data transmission and reception. The I<sup>2</sup>C module also has an arbitration detect function and clock synchronization to prevent situations where more than one master attempts to transmit data to the I<sup>2</sup>C bus at the same time.

## Serial Peripheral Interface – SPI

- Supports both master and slave mode
- Frequency of up to 36MHz for master mode and 18MHz for slave mode
- FIFO Depth: 8 levels
- Multi-master and multi-slave operation

The Serial Peripheral Interface, SPI, provides an SPI protocol data transmit and receive function in both master and slave mode. The SPI interface uses 4 pins, which are the serial data input and output lines MISO and MOSI, the clock line, SCK, and the slave select line, SEL. One SPI device acts as a master device which controls the data flow using the SEL and SCK signals to indicate the start of data communication and the data sampling rate. To receive a data byte, the streamed data bits are latched on a specific clock edge and stored in the data register or in the RX FIFO. Data transmission is carried in a similar way but with a reverse sequence. The mode fault detection provides a capability for multi-master applications.

## Universal Synchronous Asynchronous Receiver Transmitter – USART

- Operating frequency up to 4.5MHz
- Supports both asynchronous and clocked synchronous serial communication modes
- IrDA SIR encoder and decoder
- RS485 mode with output enable control
- Full Modem function for USART0
- Auto hardware flow control mode – RTS, CTS
- FIFO Depth: 16×9 bits for both receiver and transmitter

The Universal Synchronous Asynchronous Receiver Transceiver, USART, provides a flexible full duplex data exchange using synchronous or asynchronous transfer. The USART is used to translate data between parallel and serial interfaces, and is also commonly used for RS232 standard communication. The USART peripheral function supports five types of interrupt including Line Status Interrupt, Transmitter FIFO Empty Interrupt, Receiver Threshold Level Reaching Interrupt, Time Out Interrupt and MODEM Status Interrupt. The USART module includes a 16-byte transmitter FIFO (TX\_FIFO) and a 16-byte receiver FIFO (RX\_FIFO). The software can detect a USART error status by reading the Line Status Register, LSR. The status includes the type and the condition of transfer operations as well as several error conditions resulting from Parity, Overrun, Framing and Break events.

The USART includes a programmable baud rate generator which is capable of dividing the CK\_AHB to produce a clock for the USART transmitter and receiver.

## Smart Card Interface – SCI

- Support ISO 7816-3 standard
- Character mode
- Single transmit buffer and single receive buffer
- 11-bit ETU (Elementary Time Unit) counter
- 9-bit guard time counter
- 24-bit general purpose waiting time counter
- Parity generation and checking
- Automatic character retry on parity error detection in transmission and reception modes

The Smart Card Interface is compatible with the ISO 7816-3 standard. This interface includes Card Insertion/Removal detection, SCI data transfer control logic and data buffers, internal Timer Counters and corresponding control logic circuits to perform all the necessary Smart Card operations. The Smart Card interface acts as a Smart Card Reader to facilitate communication with the external Smart Card. The overall functions of the Smart Card interface are controlled by a series of registers including control and status registers together with several corresponding interrupts which are generated to get the attention of the microcontroller for SCI transfer status.

## Peripheral Direct Memory Access – PDMA

- 12 channels with trigger source grouping
- Supports Single and block transfer mode
- 8/16/32-bit width data transfer
- Supports Address increment, decrement or fixed mode
- 4-level programmable channel priority
- Auto reload mode
- Supports trigger source: CSIF, ADC, SPI, USART, I<sup>2</sup>C, GPTM, MCTM, SCI and software

The Peripheral Direct Memory Access controller, PDMA, moves data between the peripherals (USART, SPI, ADC, GPTM, MCTM, CSIF, I<sup>2</sup>C and SCI, CPU for software mode) and the system memory on the AHB bus. Each PDMA channel has a source address, destination address, block length and transfer count. The PDMA can exclude the CPU intervention and avoid interrupt service routine execution. It improves system performance as the software does not need to join each data movement operation.

## Universal Serial Bus Device Controller – USB

- Complies with USB 2.0 full-speed (12Mbps) specification
- On-chip USB full-speed transceiver
- 1 control endpoint (EP0) for control transfer
- 3 single-buffered endpoints for bulk and interrupt transfer
- 4 double-buffered endpoints for bulk, interrupt and isochronous transfer
- 1024 bytes EP-SRAM used as the endpoint data buffers

The USB device controller is compliant with USB 2.0 full-speed specification. There is one control endpoint known as Endpoint 0 and seven configurable endpoints. A 1024-byte SRAM is used as the endpoint buffers. Each endpoint buffer size is programmable using corresponding registers, which provides maximum flexibility for various applications. The integrated USB full-speed transceiver helps to minimise the overall system complexity and cost. The USB functional block also contains the resume and suspend features to meet the requirements of low-power consumption.

## CMOS Sensor Interface – CSIF (HT32F2755 only)

- Up to 2048×2048 input resolution
- Supports 8-bit YUV422 and Raw RGB formats
- Up to 24MHz input pixel clock frequency
- Multi VSYNC and HSYNC settings for image capture
- Hardware window capture function
- Fractional hardware sub-sample function
- Dual FIFOs each with a capacity of 8×32 bits which can be read by the PDMA or CPU

The CMOS Sensor Interface, otherwise known as the CSIF, provides an interface for image capture from CMOS sensors. The device can be connected to the CMOS sensor directly using its CMOS Sensor Interface. The CSIF supports both Vertical SYNC and Horizontal SYNC modes for image capture implementation. The CSIF consists of window capture and sub-sampling functions together with dual FIFOs, each with a capacity of 8×32 bits, to store data which can be moved to the internal SRAM via the Peripheral Direct Memory Access circuitry, PDMA. The CSIF does not support image data conversion or decode but rather transfers the image data received from the CMOS sensor to the internal SRAM transparently.

## Debug Support

- Serial Wire or JTAG Debug Port SWJ-DP
- 6 instruction comparators and 2 literal comparators for hardware breakpoint or code/literal patch
- 4 comparators for hardware watchpoints
- 1-bit asynchronous trace – TRACESWO

## Package and Operation Temperature

- 48/64/100-pin LQFP packages
- Operation temperature range: -40°C to +85°C



# 3 Overview

## Device Information

**Table 1. HT32F1755/1765/2755 Series Features and Peripheral List**

Peripherals		HT32F1755	HT32F1765	HT32F2755
Main Flash (KB)		127	127	127
Option Bytes Flash (KB)		1	1	1
SRAM (KB)		32	64	64
Timers	MCTM	1		
	GPTM	2		
	BFTM	2		
	RTC	1		
	WDT	1		
Communication	CSIF	—	—	1
	USB	1		
	SCI	1		
	USART	2		
	SPI	2		
	I <sup>2</sup> C	2		
GPIO		Up to 80		
EXTI		16		
12-bit ADC Number of channels		1 8 Channels		
OPA/Comparator		2		
CPU frequency		Up to 72MHz		
Operating voltage		2.7V ~ 3.6V		
Operating temperature		-40°C ~ +85°C		
Package		48/64/100-pin LQFP		

## Block Diagram

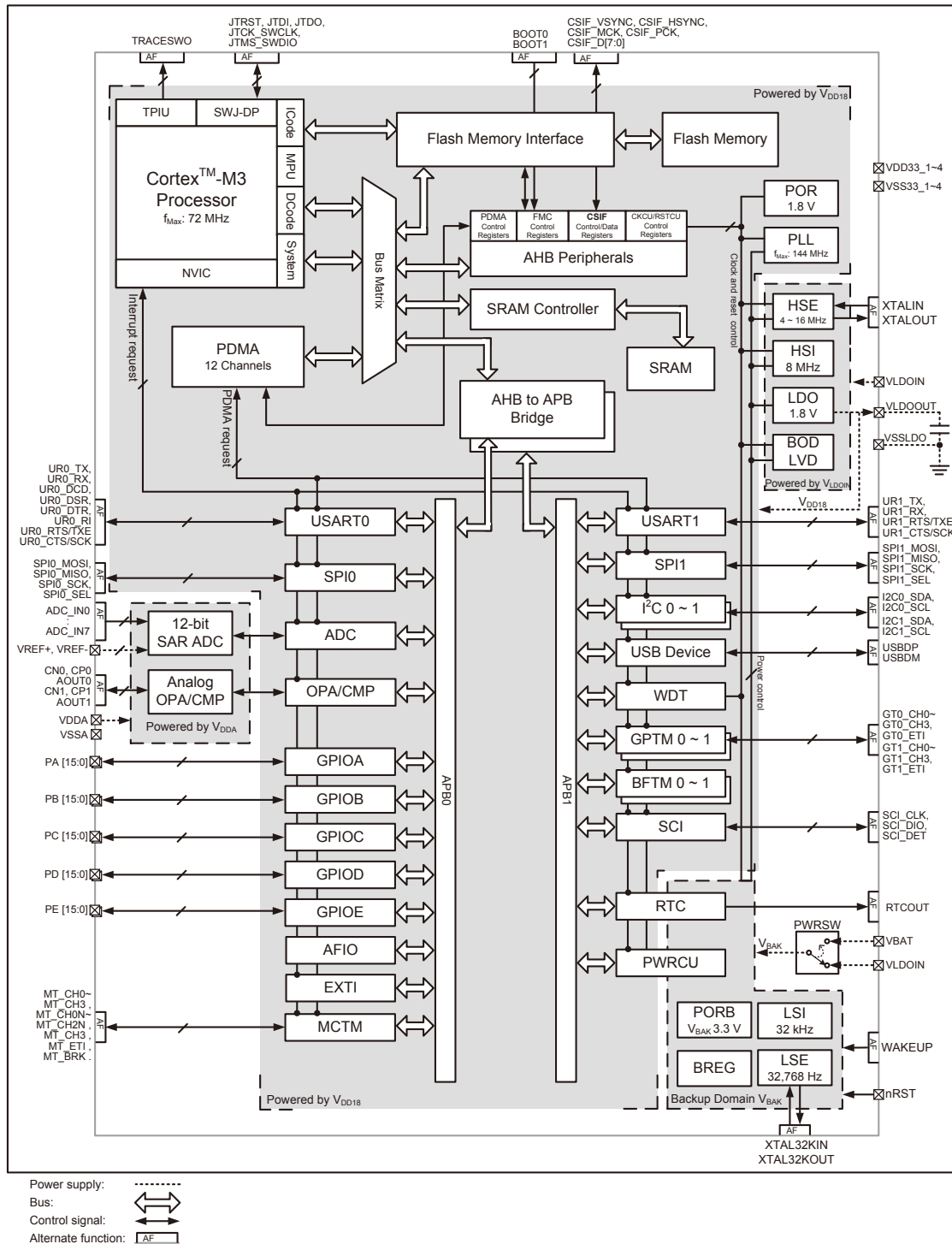

**NOTE:** The AHB peripheral function, CSIF, is only available in the HT32F2755 device.

**Figure 1. HT32F1755/1765/2755 Block Diagram**

Overview

## Memory Map

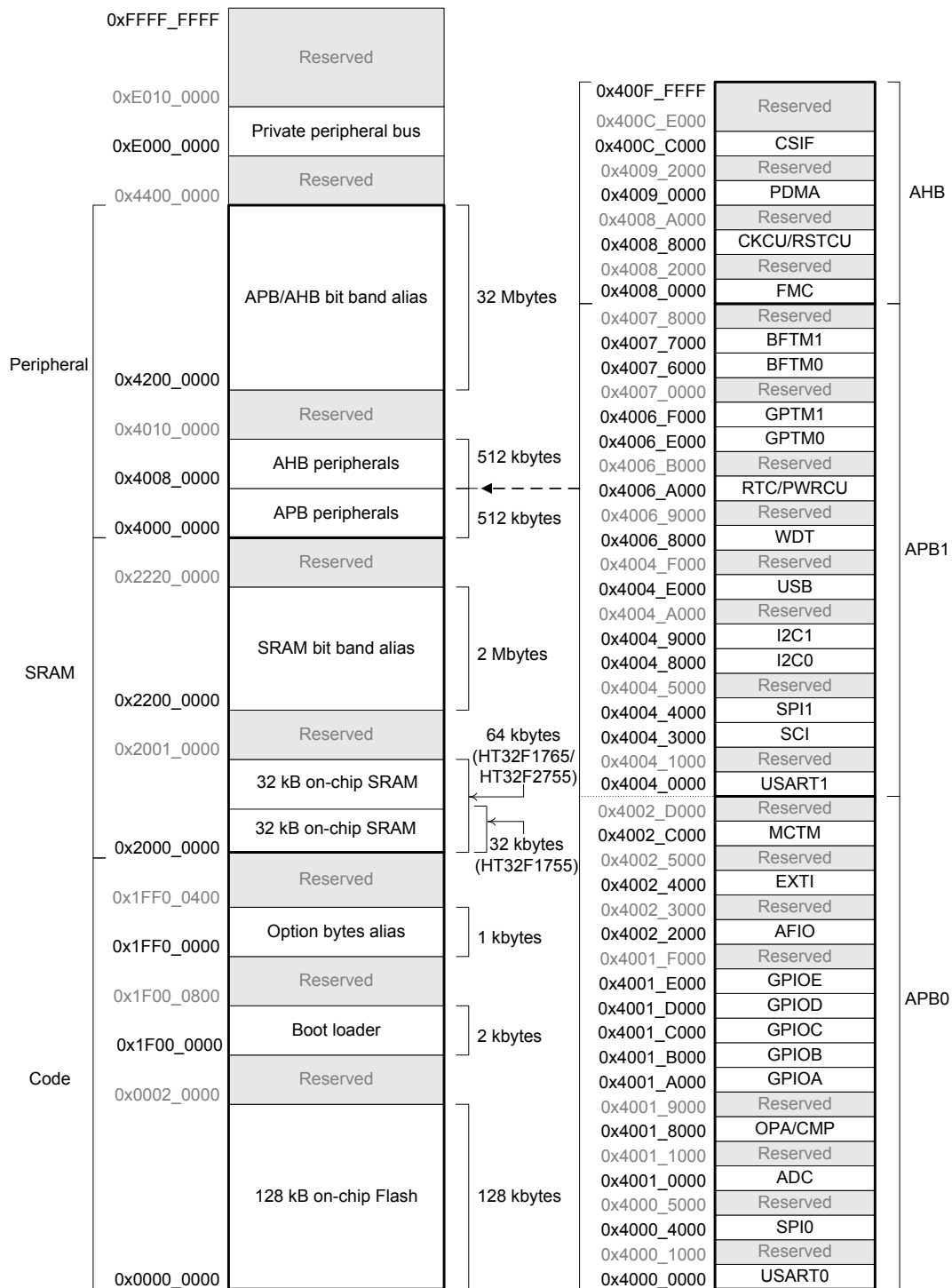

Figure 2. HT32F1755/1765/2755 Memory Map

## Clock Structure

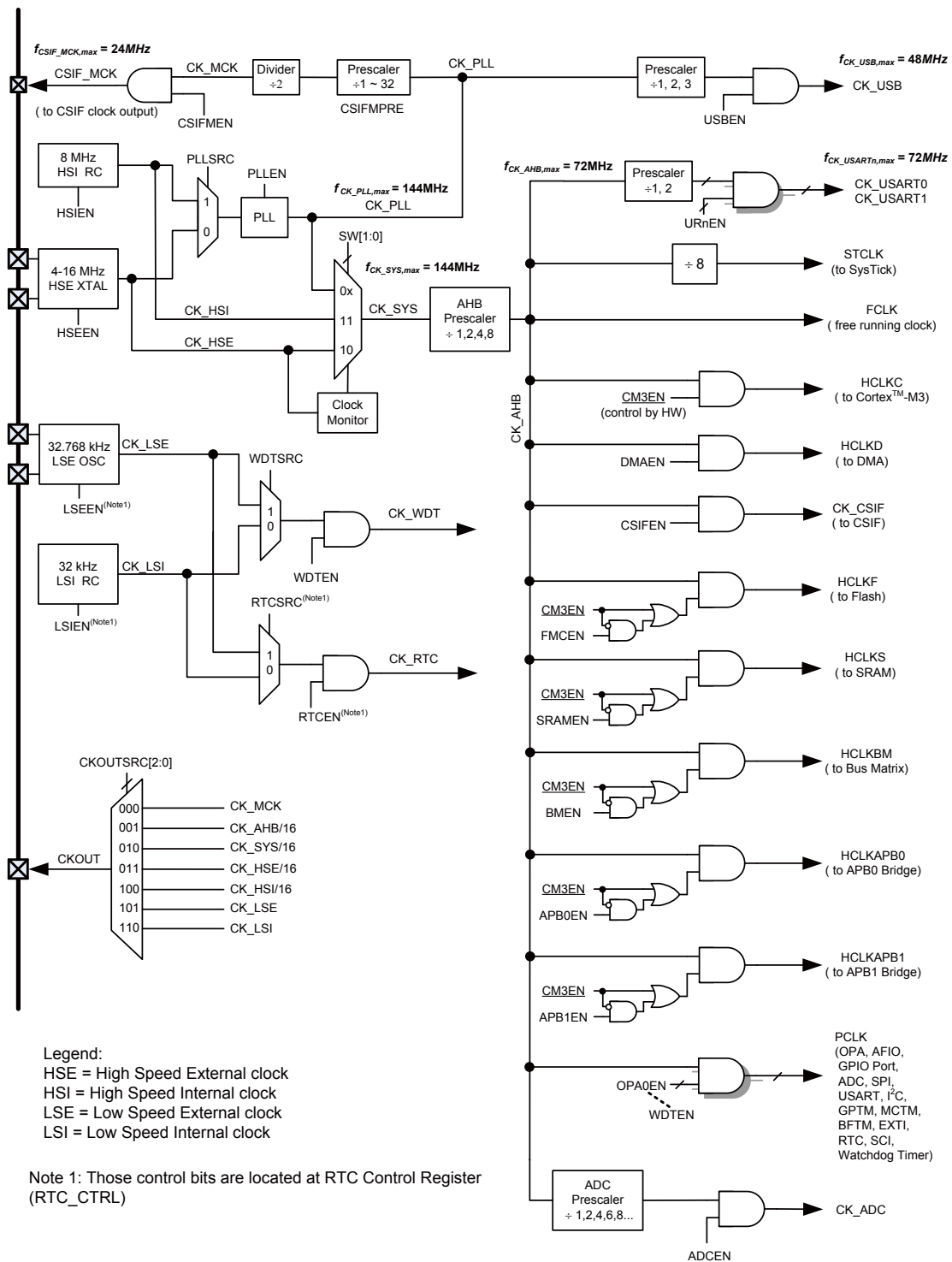

Figure 3. HT32F1755/1765/2755 Clock Structure

## Pin Assignment

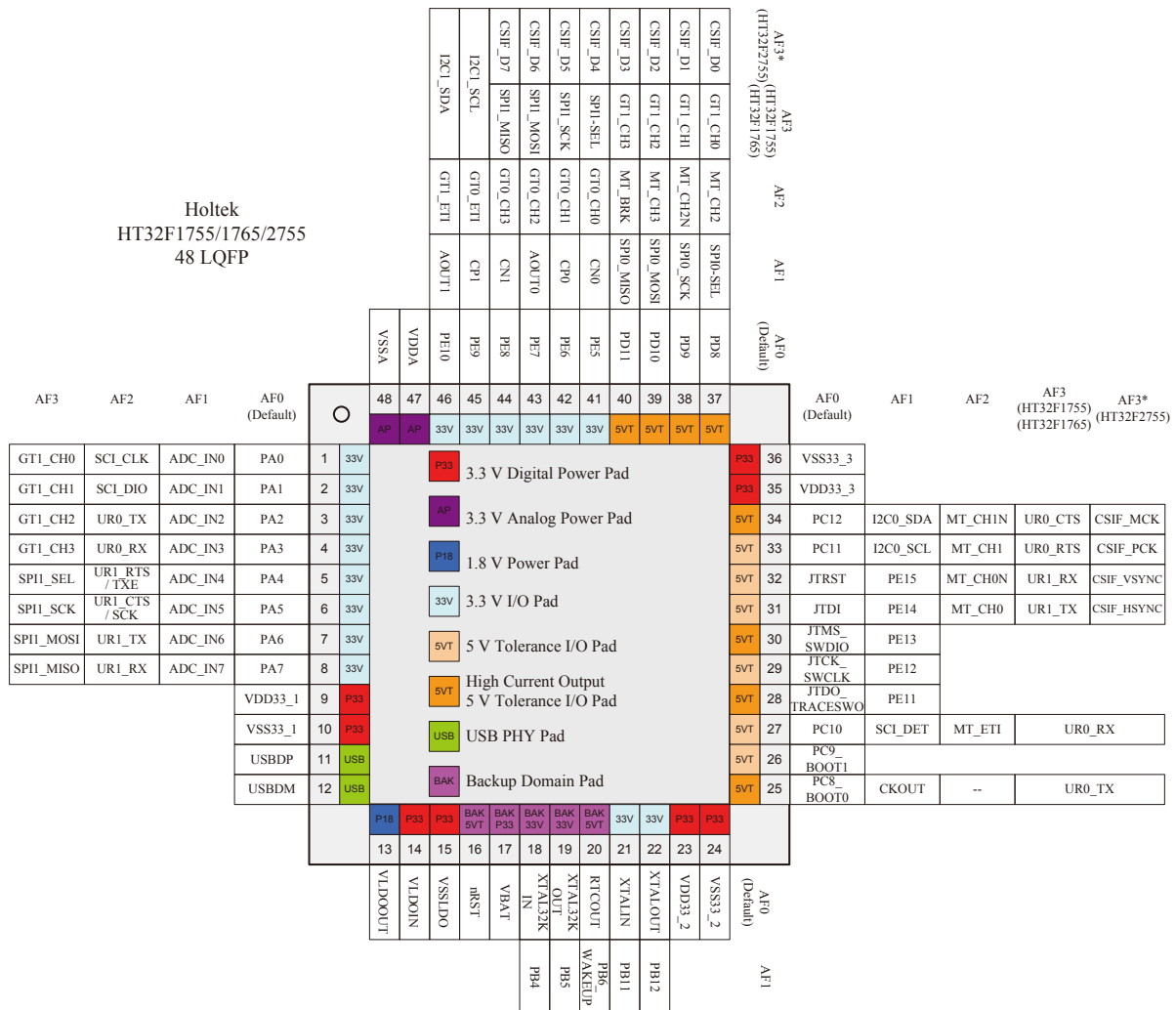

Figure 4. HT32F1755/1765/2755 48-LQFP Pin Assignment

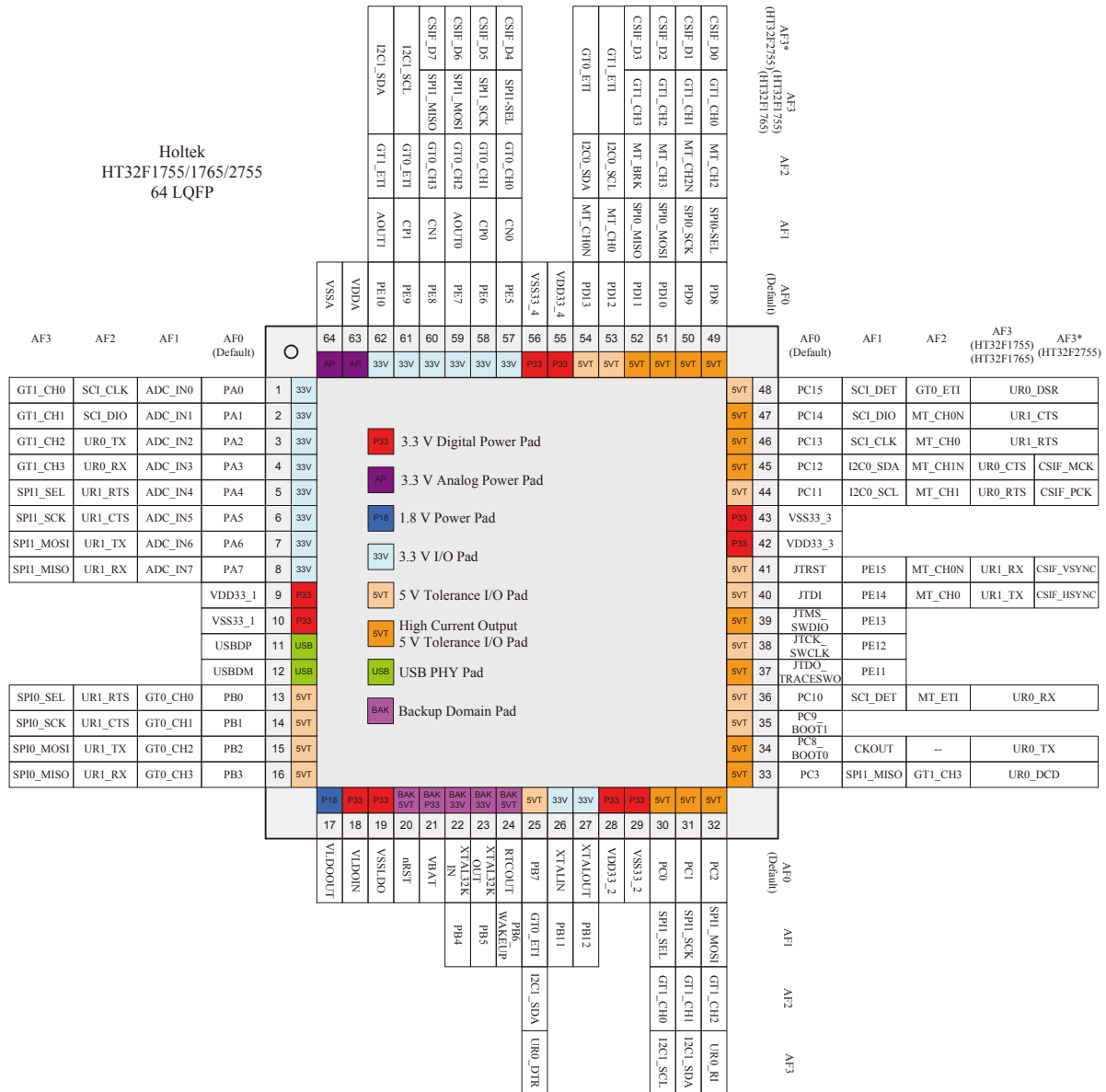

Figure 5. HT32F1755/1765/2755 64-LQFP Pin Assignment



**Table 2. HT32F1755/1765/2755 Pin Descriptions**

Pin Name	Pins			Type (Note1)	IO Level (Note2)	Description				
	48 LQFP	64 LQFP	100 LQFP			Main function (AF0)	AF1	AF2	AF3 (HT32F1755) (HT32F1765)	AF3 (HT32F2755)
PA0	1	1	1	A/I/O	—	PA0	ADC_IN0	SCI_CLK	GT1_CH0	GT1_CH0
PA1	2	2	2	A/I/O	—	PA1	ADC_IN1	SCI_DIO	GT1_CH1	GT1_CH1
PA2	3	3	3	A/I/O	—	PA2	ADC_IN2	UR0_TX	GT1_CH2	GT1_CH2
PA3	4	4	4	A/I/O	—	PA3	ADC_IN3	UR0_RX	GT1_CH3	GT1_CH3
PA4	5	5	5	A/I/O	—	PA4	ADC_IN4	UR1_RTS /TXE	SPI1_SEL	SPI1_SEL
PA5	6	6	6	A/I/O	—	PA5	ADC_IN5	UR1_CTS /SCK	SPI1_SCK	SPI1_SCK
PA6	7	7	7	A/I/O	—	PA6	ADC_IN6	UR1_TX	SPI1_MOSI	SPI1_MOSI
PA7	8	8	8	A/I/O	—	PA7	ADC_IN7	UR1_RX	SPI1_MISO	SPI1_MISO
PA8	—	—	9	I/O	5V-T	PA8	SPI1_SEL	UR0_RTS /TXE	—	—
PA9	—	—	10	I/O	5V-T	PA9	SPI1_SCK	UR0_CTS /SCK	—	—
PA10	—	—	11	I/O	5V-T	PA10	SPI1_MOSI	UR0_TX	—	—
PA11	—	—	12	I/O	5V-T	PA11	SPI1_MISO	UR0_RX	—	—
PA12	—	—	13	I/O	5V-T	PA12	GT1_CH0	—	—	—
VDD33_1	9	9	14	P	—	3.3V voltage for digital I/O				
VSS33_1	10	10	15	P	—	Ground reference for digital I/O				
USBDP	11	11	16	A/I/O	—	USB Differential data bus conforming to the Universal Serial Bus standard				
USBDM	12	12	17	A/I/O	—	USB Differential data bus conforming to the Universal Serial Bus standard				
PA13	—	—	18	I/O	5V-T	PA13	GT1_CH1	—	—	—
PA14	—	—	19	I/O	5V-T	PA14	GT1_CH2	—	—	—
PA15	—	—	20	I/O	5V-T	PA15	GT1_CH3	—	—	—
PB0	—	13	21	I/O	5V-T	PB0	GT0_CH0	UR1_RTS /TXE	SPI0_SEL	SPI0_SEL
PB1	—	14	22	I/O	5V-T	PB1	GT0_CH1	UR1_CTS /SCK	SPI0_SCK	SPI0_SCK
PB2	—	15	23	I/O	5V-T	PB2	GT0_CH2	UR1_TX	SPI0_MOSI	SPI0_MOSI
PB3	—	16	24	I/O	5V-T	PB3	GT0_CH3	UR1_RX	SPI0_MISO	SPI0_MISO
NC	—	—	25	—	—	No connection				
VLDOOUT	13	17	26	P	—	LDO 1.8V output It is recommended to connect a capacitor, denoted as C <sub>LDO</sub> , as close as possible between this pin and VSSLDO				
VLDOIN	14	18	27	P	—	LDO 3.3V power input Connected to the power switch circuitry for the internal backup domain				
VSSLDO	15	19	28	P	—	LDO ground reference				
nRST	16	20	29	I (BK)	5V- T_PU	External reset pin and external wakeup pin in Power-Down mode				
VBAT	17	21	30	P	—	VDD 3.3V for backup domain				



Pin Name	Pins			Type (Note1)	IO Level (Note2)	Description				
	48 LQFP	64 LQFP	100 LQFP			Main function (AF0)	AF1	AF2	AF3 (HT32F1755) (HT32F1765)	AF3 (HT32F2755)
XTAL-32KIN	18	22	31	A/I/O (BK)	—	XTAL32KIN	PB4	—	—	—
XTAL-32KOUT	19	23	32	A/I/O (BK)	—	XTAL32KOUT	PB5	—	—	—
RTCOUT	20	24	33	I/O (BK)	5V-T	RTCOUT	PB6_ WAKEUP	—	—	—
PB7	—	25	34	I/O	5V-T	PB7	GT0_ETI	I2C1_ SDA	UR0_DTR	UR0_DTR
PB8	—	—	35	I/O	5V-T	PB8	UR0_RTS /TXE	—	—	—
PB9	—	—	36	I/O	5V-T	PB9	UR0_CTS /SCK	—	—	—
PB10	—	—	37	I/O	5V-T	PB10	UR0_TX	—	—	—
XTALIN	21	26	38	A/I/O	—	XTALIN	PB11	—	—	—
XTALOUT	22	27	39	A/I/O	—	XTALOUT	PB12	—	—	—
VDD33_2	23	28	40	P	—	3.3V voltage for digital I/O				
VSS33_2	24	29	41	P	—	Ground reference for digital I/O				
PB13	—	—	42	I/O	5V-T	PB13	UR0_RX	—	—	—
PB14	—	—	43	I/O	5V-T	PB14	UR1_CTS /SCK	GT1_ETI	—	—
PB15	—	—	44	I/O	5V-T	PB15	UR1_RTS /TXE	—	—	—
PC0	—	30	45	I/O	5V-T	PC0	SPI1_SEL	GT1_ CH0	I2C1_SCL	I2C1_SCL
PC1	—	31	46	I/O	5V-T	PC1	SPI1_SCK	GT1_ CH1	I2C1_SDA	I2C1_SDA
PC2	—	32	47	I/O	5V-T	PC2	SPI1_ MOSI	GT1_ CH2	UR0_RI	UR0_RI
PC3	—	33	48	I/O	5V-T	PC3	SPI1_ MISO	GT1_ CH3	UR0_DCD	UR0_DCD
PC4	—	—	49	I/O	5V-T	PC4	UR1_TX	I2C0_ SCL	—	—
PC5	—	—	50	I/O	5V-T	PC5	UR1_RX	I2C0_ SDA	—	—
PC6	—	—	51	I/O	5V-T	PC6	I2C1_SCL	SCI_ CLK	—	—
PC7	—	—	52	I/O	5V-T	PC7	I2C1_SDA	SCI_DIO	—	—
PC8	25	34	53	I/O	5V-T PU	PC8_BOOT0	CKOUT	—	UR0_TX	UR0_TX
PC9	26	35	54	I/O	5V-T PU	PC9_BOOT1	—	—	—	—
PC10	27	36	55	I/O	5V-T	PC10	SCI_DET	MT_ETI	UR0_RX	UR0_RX
PE11	28	37	56	I/O	5V-T	JTDO_ TRACESWO	PE11	—	—	—

Pin Name	Pins			Type (Note1)	IO Level (Note2)	Description				
	48 LQFP	64 LQFP	100 LQFP			Main function (AF0)	AF1	AF2	AF3 (HT32F1755) (HT32F1765)	AF3 (HT32F2755)
PE12	29	38	57	I/O	5V-T_PU	JTCK_SWCLK	PE12	—	—	—
PE13	30	39	58	I/O	5V-T_PU	JTMS/SWDIO	PE13	—	—	—
PE14	31	40	59	I/O	5V-T_PU	JTDI	PE14	MT_CH0	UR1_TX	CSIF_HSYNC
PE15	32	41	60	I/O	5V-T_PU	JTRST	PE15	MT_CH0N	UR1_RX	CSIF_VSYNC
VDD33_3	—	42	61	P	—	3.3V voltage for digital I/O				
VSS33_3	—	43	62	P	—	Ground reference for digital I/O				
PC11	33	44	63	I/O	5V-T	PC11	I2C0_SCL	MT_CH1	UR0_RTS/TXE	CSIF_PCK
PC12	34	45	64	I/O	5V-T	PC12	I2C0_SDA	MT_CH1N	UR0_CTS/SCK	CSIF_MCK
PC13	—	46	65	I/O	5V-T	PC13	SCI_CLK	MT_CH0	UR1_RTS/TXE	UR1_RTS/TXE
PC14	—	47	66	I/O	5V-T	PC14	SCI_DIO	MT_CH0N	UR1_CTS/SCK	UR1_CTS/SCK
PC15	—	48	67	I/O	5V-T	PC15	SCI_DET	GT0_ETI	UR0_DSR	UR0_DSR
PD0	—	—	68	I/O	5V-T	PD0	GT0_CH0	SPI0_SEL	UR0_DTR	UR0_DTR
PD1	—	—	69	I/O	5V-T	PD1	GT0_CH1	SPI0_SCK	UR0_RI	UR0_RI
PD2	—	—	70	I/O	5V-T	PD2	GT0_CH2	SPI0_MOSI	UR0_DCD	UR0_DCD
PD3	—	—	71	I/O	5V-T	PD3	GT0_CH3	SPI0_MISO	—	—
PD4	—	—	72	I/O	5V-T	PD4	SPI1_SEL	—	—	—
PD5	—	—	73	I/O	5V-T	PD5	SPI1_SCK	—	—	—
PD6	—	—	74	I/O	5V-T	PD6	SPI1_MOSI	—	—	—
PD7	—	—	75	I/O	5V-T	PD7	SPI1_MISO	—	—	—
VDD33_3	35	—	—	P	—	3.3V voltage for digital I/O				
VSS33_3	36	—	—	P	—	Ground reference for digital I/O				
PD8	37	49	76	I/O	5V-T	PD8	SPI0_SEL	MT_CH2	GT1_CH0	CSIF_D0
PD9	38	50	77	I/O	5V-T	PD9	SPI0_SCK	MT_CH2N	GT1_CH1	CSIF_D1
PD10	39	51	78	I/O	5V-T	PD10	SPI0_MOSI	MT_CH3	GT1_CH2	CSIF_D2
PD11	40	52	79	I/O	5V-T	PD11	SPI0_MISO	MT_BRK	GT1_CH3	CSIF_D3
PD12	—	53	80	I/O	5V-T	PD12	MT_CH0	I2C0_SCL	GT1_ETI	GT1_ETI

Pin Name	Pins			Type (Note1)	IO Level (Note2)	Description				
	48 LQFP	64 LQFP	100 LQFP			Main function (AF0)	AF1	AF2	AF3 (HT32F1755) (HT32F1765)	AF3 (HT32F2755)
PD13	—	54	81	I/O	5V-T	PD13	MT_CH0N	I2C0_SDA	GT0_ETI	GT0_ETI
PD14	—	—	82	I/O	5V-T	PD14	MT_CH1	SCI_CLK	—	—
PD15	—	—	83	I/O	5V-T	PD15	MT_CH1N	SCI_DIO	—	—
PE0	—	—	84	I/O	5V-T	PE0	MT_CH2	—	—	—
VDD33_4	—	55	85	P	—	3.3V voltage for digital I/O				
VSS33_4	—	56	86	P	—	Ground reference for digital I/O				
PE1	—	—	87	I/O	5V-T	PE1	MT_CH2N	—	—	—
PE2	—	—	88	I/O	5V-T	PE2	MT_CH3	—	—	—
PE3	—	—	89	I/O	5V-T	PE3	MT_BRK	—	—	—
PE4	—	—	90	I/O	5V-T	PE4	MT_ETI	—	—	—
PE5	41	57	91	A/I/O	—	PE5	CN0	GT0_CH0	SPI1_SEL	CSIF_D4
PE6	42	58	92	A/I/O	—	PE6	CP0	GT0_CH1	SPI1_SCK	CSIF_D5
PE7	43	59	93	A/I/O	—	PE7	AOUT0	GT0_CH2	SPI1_MOSI	CSIF_D6
PE8	44	60	94	A/I/O	—	PE8	CN1	GT0_CH3	SPI1_MISO	CSIF_D7
PE9	45	61	95	A/I/O	—	PE9	CP1	GT0_ETI	I2C1_SCL	I2C1_SCL
PE10	46	62	96	A/I/O	—	PE10	AOUT1	GT1_ETI	I2C1_SDA	I2C1_SDA
VDDA	47	63	97	P	—	3.3V analog voltage for ADC and OPA/Comparator				
VREF+	—	—	98	P	—	ADC positive reference voltage has to be lower or equal to VDDA				
VREF-	—	—	99	P	—	ADC negative reference voltage has to be directly connected to VSSA				
VSSA	48	64	100	P	—	Ground reference for the ADC and OPA/Comparator				

- NOTES:**
1. I = input, O = output, A = Analog port, P = power supply, PU = pull-up, BK = Back-up domain.
  2. 5V-T = 5V tolerant.
  3. The GPIOs are in an AF0 state after a  $V_{DD18}$  power on reset (POR) except for the RTCOUT pin of in the Backup Domain I/O. The RTCOUT pin is reset by the Backup Domain power-on-reset (PORB) or by a Backup Domain software reset (BAK\_RST bit in BAK\_CR register).
  4. The backup domain of I/O pins has drive current capability limitation of  $< 1\text{mA} @ V_{BAT} = 3.3\text{V}$ .

# 4 Electrical Characteristics

## Absolute Maximum Ratings

The following table shows the absolute maximum ratings of the device. These are stress ratings only. Stresses beyond absolute maximum ratings may cause permanent damage to the device. Note that the device is not guaranteed to operate properly at the maximum ratings. Exposure to the absolute maximum rating conditions for extended periods may affect device reliability.

**Table 3. Absolute Maximum Ratings**

Symbol	Parameter	Min	Max	Unit
V <sub>DD33</sub>	External main supply voltage	V <sub>SS</sub> - 0.3	V <sub>SS</sub> + 3.6	V
V <sub>DDA</sub>	External analog supply voltage	V <sub>SSA</sub> - 0.3	V <sub>SSA</sub> + 3.6	V
V <sub>BAT</sub>	External battery supply voltage	V <sub>SS</sub> - 0.3	V <sub>SS</sub> + 3.6	V
V <sub>LDOIN</sub>	External LDO supply voltage	V <sub>SS</sub> - 0.3	V <sub>SS</sub> + 3.6	V
V <sub>IN</sub>	Input voltage on 5V-tolerant I/O	V <sub>SS</sub> - 0.3	V <sub>SS</sub> + 5.5	V
	Input voltage on other I/O	V <sub>SS</sub> - 0.3	V <sub>DD33</sub> + 0.3	V
T <sub>A</sub>	Ambient operating temperature range	-40	+85	°C
T <sub>STG</sub>	Storage temperature range	-55	+150	°C
T <sub>J</sub>	Maximum junction temperature	—	125	°C
P <sub>D</sub>	Total power dissipation	—	500	mW
V <sub>ESD</sub>	Electrostatic discharge voltage (human body mode)	-4000	+4000	V

## Recommended DC Characteristics

**Table 4. Recommended DC Operating Conditions**

T<sub>A</sub> = 25°C, unless otherwise specified.

Symbol	Parameter	Conditions	Min	Typ	Max	Unit
V <sub>DD33</sub>	I/O Operating voltage	—	2.7	3.3	3.6	V
V <sub>DDA</sub>	Analog operating voltage	—	2.7	3.3	3.6	V
V <sub>BAT</sub>	Battery supply operating voltage	—	2.7	3.3	3.6	V
V <sub>LDOIN</sub>	LDO operating voltage	—	2.7	3.3	3.6	V

## On-Chip LDO Voltage Regulator Characteristics

**Table 5. LDO Characteristics**

T<sub>A</sub> = 25°C, unless otherwise specified.

Symbol	Parameter	Conditions	Min	Typ	Max	Unit
V <sub>LDOOUT</sub>	Internal regulator output voltage	V <sub>LDOIN</sub> = 3.3V Regulator input	1.71	1.8	1.89	V
I <sub>LDOOUT</sub>	Output current	V <sub>LDOIN</sub> = 2.7V Regulator input	—	—	200	mA
C <sub>LDO</sub>	External filter capacitor value for internal core power supply	The capacitor value is dependent on the core power current consumption	2.2	—	10	μF

## Power Consumption

**Table 6. Power Consumption Characteristics**

T<sub>A</sub> = 25°C, unless otherwise specified.

Symbol	Parameter	Conditions	Min	Typ	Max	Unit
I <sub>DD</sub>	Supply current (Run mode)	V <sub>DD33</sub> = V <sub>BAT</sub> = 3.3V, HSE = 8MHz, PLL = 144MHz, f <sub>HCLK</sub> = 72MHz, f <sub>PCLK</sub> = 72MHz, All peripherals enabled	—	60	72	mA
		V <sub>DD33</sub> = V <sub>BAT</sub> = 3.3V, HSE = 8MHz, PLL = 144MHz, f <sub>HCLK</sub> = 72MHz, f <sub>PCLK</sub> = 72MHz, All peripherals disabled	—	27	34	mA
	Supply current (Sleep mode)	V <sub>DD</sub> = V <sub>BAT</sub> = 3.3V, HSE = 8MHz, PLL = 144MHz, f <sub>HCLK</sub> = 0MHz, f <sub>PCLK</sub> = 72MHz, All peripherals enabled	—	42	50	mA
		V <sub>DD33</sub> = V <sub>BAT</sub> = 3.3V, HSE = 8MHz, PLL = 144MHz, f <sub>HCLK</sub> = 0MHz, f <sub>PCLK</sub> = 72MHz, All peripherals disabled	—	9	12	mA
	Supply current (Deep-Sleep1 mode)	V <sub>DD33</sub> = V <sub>BAT</sub> = 3.3V, All clock off (HSE/PLL/f <sub>HCLK</sub> ), LDO in low power mode, LSI on, RTC on	—	58	90	μA
	Supply current (Deep-Sleep2 mode)	V <sub>DD33</sub> = V <sub>BAT</sub> = 3.3V, All clock off (HSE/PLL/f <sub>HCLK</sub> ), LDO off (DMOS on), LSI on, RTC on	—	18	25	μA
	Supply current (Power-Down mode)	V <sub>DD33</sub> = V <sub>BAT</sub> = 3.3V, LDO off, LSE on, LSI off, RTC on	—	—	—	μA
		V <sub>DD33</sub> = V <sub>BAT</sub> = 3.3V, LDO off, LSE on, LSI off, RTC off	—	—	—	μA
		V <sub>DD33</sub> = V <sub>BAT</sub> = 3.3V, LDO off, LSE off, LSI on, RTC on	—	—	—	μA
		V <sub>DD33</sub> = V <sub>BAT</sub> = 3.3V, LDO off, LSE off, LSI on, RTC off	—	5	6	μA
I <sub>BAT</sub>	Battery supply current (Power-Down mode)	V <sub>DD33</sub> not present, V <sub>BAT</sub> = 3.3V, LDO off, LSE off, LSI on, RTC on	—	4	—	μA
		V <sub>DD33</sub> not present, V <sub>BAT</sub> = 3.3V, LDO off, LSE off, LSI on, RTC off	—	3.9	—	μA

- NOTES:**
1. HSE is the high speed external oscillator. HSI means 8MHz high speed internal oscillator.
  2. LSE means low speed external oscillator. LSI means 32.768KHz low speed internal oscillator.
  3. RTC means real time clock.
  4. Code = while (1) { 208 NOP } executed in Flash.

## Reset and Supply Monitor Characteristics

**Table 7. LVD/BOD Characteristics**

T<sub>A</sub> = 25°C, unless otherwise specified.

Symbol	Parameter	Conditions	Min	Typ	Max	Unit
V <sub>BOD</sub>	Brown Out Detector Voltage	—	—	2.6	—	V
V <sub>LVD</sub>	Voltage of Low Voltage Detector	LVDS <sup>(Note1)</sup> = '00'	—	2.7	—	V
		LVDS <sup>(Note1)</sup> = '01'	—	2.8	—	V
		LVDS <sup>(Note1)</sup> = '10'	—	2.9	—	V
		LVDS <sup>(Note1)</sup> = '11'	—	3.0	—	V
V <sub>POR</sub>	Power On Reset Voltage	—	—	1.36	—	V

**NOTE:** LVDS field is in PWRUCU LVDCSR register.

## External Clock Characteristics

**Table 8. High Speed External Clock (HSE) Characteristics**

$T_A = 25^\circ\text{C}$ , unless otherwise specified.

Symbol	Parameter	Conditions	Min	Typ	Max	Unit
$f_{\text{HSE}}$	High Speed External oscillator frequency (HSE)	$V_{\text{DD33}} = 3.3\text{V}$	4	—	16	MHz
$C_{\text{HSE}}$	Recommended load capacitance on XTAL32IN and XTAL32OUT pins	—	—	TBD	—	pF
$R_{\text{FHSE}}$	Recommended external feedback resistor between XTAL32IN and XTAL32OUT pins	—	—	1.0	—	$\text{M}\Omega$
$D_{\text{HSE}}$	HSE Oscillator Duty cycle	—	40	—	60	%
$I_{\text{DDHSE}}$	HSE Oscillator Operating Current	$V_{\text{DD33}} = 3.3\text{V}$ , $T_A = 25^\circ\text{C}$	—	0.96	—	mA
$I_{\text{STBHSE}}$	HSE Oscillator Standby current	$V_{\text{DD33}} = 3.3\text{V}$ , $T_A = 25^\circ\text{C}$	—	—	0.1	$\mu\text{A}$
$t_{\text{SUHSE}}$	HSE Oscillator Startup time	$V_{\text{DD33}} = 3.3\text{V}$ , $T_A = 25^\circ\text{C}$	—	—	4	ms

**Table 9. Low Speed External Clock (LSE) Characteristics**

$T_A = 25^\circ\text{C}$ , unless otherwise specified.

Symbol	Parameter	Conditions	Min	Typ	Max	Unit
$f_{\text{LSE}}$	Low Speed External oscillator frequency (LSE)	$V_{\text{DD33}} = V_{\text{BAT}} = 3.3\text{V}$	—	32.768	—	kHz
$C_{\text{LSE}}$	Recommended load capacitance on XTAL32KIN and XTAL32KOUT pins	—	—	TBD	—	pF
$R_{\text{FLSE}}$	Recommended external feedback resistor between XTAL32KIN and XTAL32KOUT pins	—	—	10	—	$\text{M}\Omega$
$D_{\text{LSE}}$	LSE Oscillator Duty cycle	—	40	—	60	%
$I_{\text{DDLSE}}$	LSE Oscillator Operating Current	$V_{\text{DD33}} = V_{\text{BAT}} = 3.3\text{V}$ , $\text{LSESM} = 0$ (Normal startup mode)	—	1.7	—	$\mu\text{A}$
$I_{\text{STBLSE}}$	LSE Oscillator Standby current	$V_{\text{DD33}} = V_{\text{BAT}} = 3.3\text{V}$ , $\text{LSESM} = 1$ (Fast startup mode)	—	3	8	$\mu\text{A}$
$t_{\text{SULSE}}$	LSE Oscillator Startup time	$V_{\text{DD33}} = V_{\text{BAT}} = 3.3\text{V}$ , $\text{LSESM} = 1$ (Fast startup mode)	—	200	—	ms

## Internal Clock Characteristics

**Table 10. High Speed Internal Clock (HSI) Characteristics**

$T_A = 25^\circ\text{C}$ , unless otherwise specified.

Symbol	Parameter	Conditions	Min	Typ	Max	Unit
$f_{\text{HSI}}$	High Speed Internal Oscillator Frequency (HSI)	$V_{\text{DD33}} = 3.3\text{V}$ , $T_A = -40^\circ\text{C} \sim +85^\circ\text{C}$	—	8	—	MHz
$\text{ACC}_{\text{HSI}}$	HSI Oscillator Frequency accuracy	Factory-trimmed, $V_{\text{DD33}} = 3.3\text{V}$ , $T_A = -40^\circ\text{C} \sim +85^\circ\text{C}$	-5	—	+5	%
$D_{\text{HSI}}$	HSI Oscillator Duty cycle	$V_{\text{DD33}} = 3.3\text{V}$ , $f_{\text{HSI}} = 8\text{MHz}$	35	—	65	%
$I_{\text{DDHSI}}$	HSI Oscillator Operating Current	$V_{\text{DD33}} = 3.3\text{V}$ , $f_{\text{HSI}} = 8\text{MHz}$	—	0.92	—	mA
$t_{\text{SUHSI}}$	HSI Oscillator Startup time	$V_{\text{DD33}} = 3.3\text{V}$ , $f_{\text{HSI}} = 8\text{MHz}$ , HSIRCBL = 0 (HSI Ready Counter Bits Length 7 Bits)	—	17	—	$\mu\text{s}$

**NOTE:** HSIRCBL field is in PWRCU HSIRCR register.

**Table 11. Low Speed Internal Clock (LSI) Characteristics**

$T_A = 25^\circ\text{C}$ , unless otherwise specified.

Symbol	Parameter	Conditions	Min	Typ	Max	Unit
$f_{\text{LSI}}$	Low Speed Internal Oscillator Frequency(LSI)	$V_{\text{DD33}} = V_{\text{BAT}} = 3.3\text{V}$ , $T_A = -40^\circ\text{C} \sim +85^\circ\text{C}$	25	32	43	kHz
$I_{\text{DDL SI}}$	LSI Oscillator Operating Current	$V_{\text{DD33}} = V_{\text{BAT}} = 3.3\text{V}$ , $T_A = 25^\circ\text{C}$	—	1.0	2	$\mu\text{A}$
$t_{\text{SULSI}}$	LSI Oscillator Startup time	$V_{\text{DD33}} = V_{\text{BAT}} = 3.3\text{V}$ , $T_A = 25^\circ\text{C}$	—	35	—	ms

## PLL Characteristics

**Table 12. PLL Characteristics**

$T_A = 25^\circ\text{C}$ , unless otherwise specified.

Symbol	Parameter	Conditions	Min	Typ	Max	Unit
$f_{\text{PLLIN}}$	PLL input clock	—	4	—	16	MHz
$f_{\text{PLL}}$	PLL output clock	—	8	—	144	MHz
$t_{\text{LOCK}}$	PLL lock time	—	—	TBD	—	ms

## Memory Characteristics

**Table 13. Flash Memory Characteristics**

$T_A = 25^\circ\text{C}$ , unless otherwise specified.

Symbol	Parameter	Conditions	Min	Typ	Max	Unit
$N_{\text{ENDU}}$	Number of guaranteed program /erase cycles before failure. (Endurance)	$T_A = -40^\circ\text{C} \sim +85^\circ\text{C}$	20	—	—	kcycles
$T_{\text{RET}}$	Data retention time	$T_A = 25^\circ\text{C}$	100	—	—	Years
$t_{\text{PROG}}$	Word programming time	$T_A = -40^\circ\text{C} \sim +85^\circ\text{C}$	40	—	—	$\mu\text{s}$
$t_{\text{ERASE}}$	Page erase time	$T_A = -40^\circ\text{C} \sim +85^\circ\text{C}$	20	—	40	ms
$t_{\text{MERASE}}$	Mass erase time	$T_A = -40^\circ\text{C} \sim +85^\circ\text{C}$	20	—	40	ms

## I/O Port Characteristics

Table 14. I/O Port Characteristics

T<sub>A</sub> = 25°C, unless otherwise specified.

Symbol	Parameter	Conditions	Min	Typ	Max	Unit	
I <sub>IL</sub>	Low level input current	3.3V IO	V <sub>I</sub> = 0V, On-chip pull-up resistor disabled.	—	—	3	μA
		5V-tolerant IO		—	—	3	μA
		Reset pin		—	—	3	μA
I <sub>IH</sub>	High level input current	3.3V IO	V <sub>I</sub> = V <sub>DD33</sub> , On-chip pull-down resistor disabled.	—	—	3	μA
		5V-tolerant IO		—	—	3	μA
		Reset pin		—	—	3	μA
V <sub>IL</sub>	Low level input voltage	3.3V IO	-0.3	—	0.8	V	
		5V-tolerant IO	-0.3	—	0.8	V	
		Reset pin	-0.3	—	0.8	V	
V <sub>IH</sub>	High level input voltage	3.3V IO	2	—	3.6	V	
		5V-tolerant IO	2	—	5.5	V	
		Reset pin	2	—	5.5	V	
V <sub>HYS</sub>	Schmitt Trigger Input Voltage Hysteresis	3.3V IO	—	400	—	mV	
		5V-tolerant IO	—	400	—	mV	
		Reset pin	—	400	—	mV	
I <sub>OL</sub>	Low level output current (GPO Sink current)	3.3V IO 4mA drive, V <sub>OL</sub> = 0.4V	4	—	—	mA	
		3.3V IO 8mA drive, V <sub>OL</sub> = 0.4V	8	—	—	mA	
		5V-tolerant 8mA drive IO, V <sub>OL</sub> =0.4V	8	—	—	mA	
		5V-tolerant 12mA drive IO, V <sub>OL</sub> =0.4V	12	—	—	mA	
		Backup Domain IO drive @ V <sub>BAT</sub> = 3.3V, V <sub>OL</sub> = 0.4V, PB4, PB5, PB6	—	—	1	mA	
I <sub>OH</sub>	High level output current (GPO Source current)	3.3V I/O 4mA drive, V <sub>OH</sub> =V <sub>DD33</sub> - 0.4V	4	—	—	mA	
		3.3V I/O 8mA drive, V <sub>OH</sub> =V <sub>DD33</sub> - 0.4V	8	—	—	mA	
		5V-tolerant I/O 8mA drive, V <sub>OH</sub> = V <sub>DD33</sub> - 0.4V	8	—	—	mA	
		5V-tolerant I/O 12mA drive, V <sub>OH</sub> = V <sub>DD33</sub> - 0.4V	12	—	—	mA	
		Backup Domain IO drive@V <sub>BAT</sub> =3.3V, V <sub>OH</sub> = V <sub>DD33</sub> - 0.4V, PB4, PB5, PB6	—	—	1	mA	
V <sub>OL</sub>	Low level output voltage	3.3V 4mA drive IO, I <sub>OL</sub> = 4mA	—	—	0.4	V	
		3.3V 8mA drive IO, I <sub>OL</sub> = 8mA	—	—	0.4	V	
		5V-tolerant 8mA drive IO, I <sub>OL</sub> =8mA	—	—	0.4	V	
		5V-tolerant 12mA drive IO, I <sub>OL</sub> =12mA	—	—	0.4	V	
V <sub>OH</sub>	High level output voltage	3.3V 4mA drive IO, I <sub>OH</sub> = 4mA	V <sub>DD33</sub> - 0.4V	—	—	V	
		3.3V 8mA drive IO, I <sub>OH</sub> = 8mA	V <sub>DD33</sub> - 0.4V	—	—	V	
		5V-tolerant 8mA drive IO, I <sub>OH</sub> =8mA	V <sub>DD33</sub> - 0.4V	—	—	V	
		5V-tolerant 12mA drive IO, I <sub>OH</sub> =12mA	V <sub>DD33</sub> - 0.4V	—	—	V	



Symbol	Parameter	Conditions	Min	Typ	Max	Unit
R <sub>PU</sub>	Internal pull-up resistor	3.3V I/O	34	—	74	kΩ
		5V-tolerant I/O	38	—	89	kΩ
R <sub>PD</sub>	Internal pull-down resistor	3.3V I/O	29	—	86	kΩ
		5V-tolerant I/O	35	—	107	kΩ

## ADC Characteristics

Table 15. ADC Characteristics

T<sub>A</sub> = 25°C, unless otherwise specified.

Symbol	Parameter	Conditions	Min	Typ	Max	Unit
V <sub>DDA</sub>	Operating voltage	—	2.7	3.3	3.6	V
V <sub>ADCIN</sub>	A/D Converter input voltage range	—	0	—	V <sub>REF+</sub>	V
V <sub>REF+</sub>	A/D Converter Reference voltage	—	—	V <sub>DDA</sub>	V <sub>DDA</sub>	V
I <sub>ADC</sub>	Current consumption	V <sub>DDA</sub> = 3.3V	—	1	TBD	mA
I <sub>ADC_DN</sub>	Power down current consumption	V <sub>DDA</sub> = 3.3V	—	1	10	μA
f <sub>ADC</sub>	A/D Converter clock	—	0.7	—	14	MHz
f <sub>s</sub>	Sampling rate	—	0.05	—	1	MHz
f <sub>ADCCONV</sub>	A/D Converter conversion time	—	—	14	—	1/f <sub>ADC</sub> Cycles
R <sub>i</sub>	Input sampling switch resistance	—	—	—	1	kΩ
C <sub>i</sub>	Input sampling capacitance	No pin/pad capacitance included	—	—	5	pF
t <sub>SU</sub>	Start up time	—	—	—	1	μs
N	Resolution	—	—	12	—	bits
INL	Integral Non-linearity error	f <sub>s</sub> = 1MHz, V <sub>DDA</sub> = 3.3V	—	±2	±5	LSB
DNL	Differential Non-linearity error	f <sub>s</sub> = 1MHz, V <sub>DDA</sub> = 3.3V	—	—	±1	LSB
E <sub>O</sub>	Offset error	—	—	—	±10	LSB
E <sub>G</sub>	Gain error	—	—	—	±10	LSB

**NOTES:** 1. Guaranteed by design, not tested in production.

2. The figure below shows the equivalent circuit of the A/D Converter Sample-and-Hold input stage where C<sub>i</sub> is the storage capacitor, R<sub>i</sub> is the resistance of the sampling switch and R<sub>s</sub> is the output impedance of the signal source V<sub>s</sub>. Normally the sampling phase duration is approximately, 1.5/f<sub>ADC</sub>. The capacitance, C<sub>i</sub>, must be charged within this time frame and it must be ensured that the voltage at its terminals becomes sufficiently close to V<sub>s</sub> for accuracy. To guarantee this, R<sub>s</sub> may not have an arbitrarily large value.

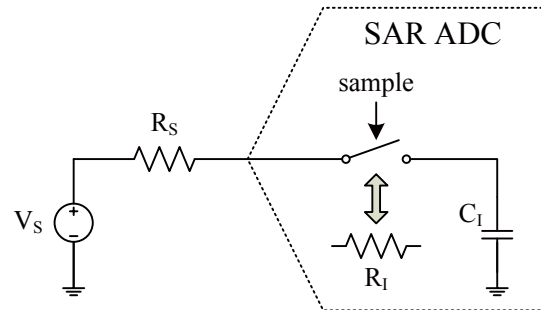

**Figure 7. ADC Sampling Network Model**

The worst case occurs when the extremities of the input range (0V and  $V_{REF}$ ) are sampled consecutively. In this situation a sampling error below 1/4 LSB is ensured by using the following equation:

$$R_S < \frac{1.5}{f_{ADC} C_I \ln(2^{N+2})} - R_I$$

where  $f_{ADC}$  is the ADC clock frequency and N is the ADC resolution (N = 12 in this case). A safe margin should be considered due to the pin/pad parasitic capacitances, which are not accounted for in this simple model.

If, in a system where this A/D Converter is used, there are no rail-to-rail input voltage variations between consecutive sampling phases,  $R_S$  may be larger than the value indicated by the equation above.

## Operation Amplifier/Comparator Characteristics

**Table 16. OPA/CMP Characteristics**

$T_A = 25^\circ\text{C}$ , unless otherwise specified.

Symbol	Parameter	Conditions	Min	Typ	Max	Unit
$V_{DDA}$	Operating voltage	—	2.7	3.3	3.6	V
$I_{OPA/CMP}$	Typical operating current	—	—	230	—	$\mu\text{A}$
$I_{OPA/CMP\_DN}$	Power down supply current	Assign registers OPAEN = 0 and EN_OPAOP = 0	—	—	0.1	$\mu\text{A}$
$V_{IOS}$	Input offset voltage	$V_{DDA} = 3.3\text{V}$ , AnOF[5:0] = '100000'	-15	—	15	mV
		$V_{DDA} = 3.3\text{V}$ , After calibration	-1	—	1	mV
$V_{IOS\_DRIFT}$	Input offset voltage drift	$T_A = -40^\circ\text{C} \sim +85^\circ\text{C}$	—	—	0.04	$\text{mV}/^\circ\text{C}$
$R_{INPUT}$	Input resistance	—	—	10	—	$\text{M}\Omega$
GV	Voltage Gain	—	60	100	—	dB
$U_t$	Unit-Gain Bandwidth	$R_L = 100\text{k}\Omega$	—	1.3	—	MHz
		$R_L = 100\text{k}\Omega$ , $C_L = 100\text{pF}$	—	1.24	—	
$V_{CM}$	Common mode voltage range	$V_{DDA} = 3.3\text{V}$	$V_{SSA}$	—	$V_{DDA} - 1.2$	V
$V_{OV}$	OPA output voltage swing	$V_{DDA} = 3.3\text{V}$	$V_{SSA} + 0.3$	—	$V_{DDA} - 0.5$	V
$t_{RT}$	Comparator response time	$V_{DDA} = 3.3\text{V}$ ; Input Overdrive = $\pm 10\text{mV}$	—	1	—	$\mu\text{s}$
SR	Slew Rate	$V_{DDA} = 3.3\text{V}$ ; Output capacitor load $C_L = 100\text{pF}$	—	1.6	—	$\text{V}/\mu\text{s}$

**NOTE:** Guaranteed by design, not tested in production.

## GPTM/MCTM Characteristics

**Table 17. GPTM/MCTM Characteristics**

Symbol	Parameter	Conditions	Min	Typ	Max	Unit
$f_{TM}$	Timer clock source for GPTM and MCTM	—	—	—	72	MHz
$t_{RES}$	Timer resolution time	—	1	—	—	$f_{TM}$
$f_{EXT}$	External signal frequency on channel 1 ~ 4	—	—	—	1/2	$f_{TM}$
RES	Timer resolution	—	—	—	16	bits

## I<sup>2</sup>C Characteristics

**Table 18. I<sup>2</sup>C Characteristics**

Symbol	Parameter	Conditions	Min	Typ	Max	Unit
$f_{SCL}$	SCL clock frequency	—	—	—	400	kHz
$t_{SCL(H)}$	SCL clock high time	—	600	—	—	ns
$t_{SCL(L)}$	SCL clock low time	—	1300	—	—	ns
$t_{FALL}$	SCL and SDA fall time	—	—	—	300	ns
$t_{RISE}$	SCL and SDA rise time	—	—	—	300	ns
$t_{SU(STA)}$	START condition setup time	—	600	—	—	ns
$t_{H(STA)}$	START condition hold time	—	600	—	—	ns
$t_{SU(SDA)}$	SDA data setup time	—	100	—	—	ns
$t_{H(SDA)}$	SDA data hold time	—	0	—	—	ns
$t_{SU(STO)}$	STOP condition setup time	—	600	—	—	ns

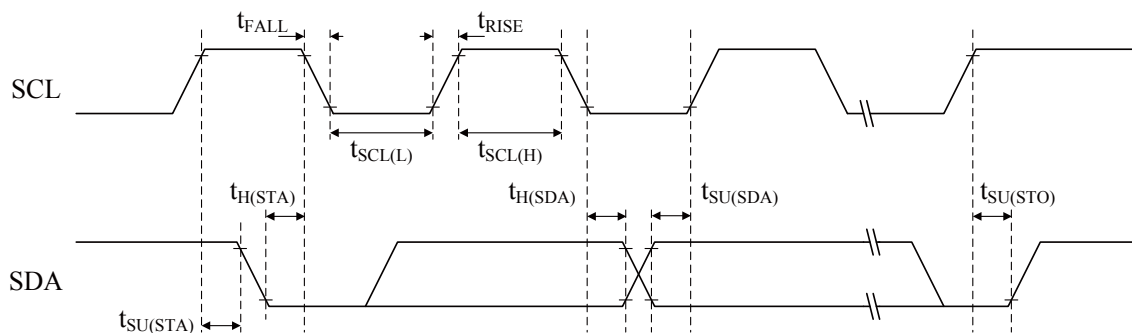
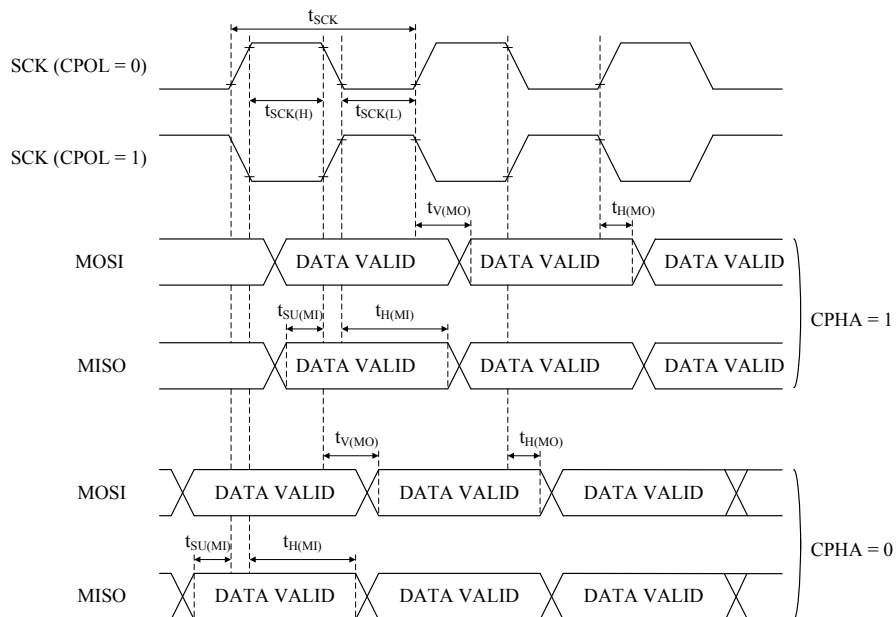

**Figure 8. I<sup>2</sup>C Timing Diagrams**

## SPI Characteristics

**Table 19. SPI Characteristics**

Symbol	Parameter	Conditions	Min	Typ	Max	Unit
$f_{SCK}$	SCK clock frequency	—	—	—	$f_{PCLK}/4$	MHz
$t_{SCK(H)}$	SCK clock high time	—	$f_{PCLK}/8$	—	—	ns
$t_{SCK(L)}$	SCK clock low time	—	$f_{PCLK}/8$	—	—	ns
<b>SPI Master mode</b>						
$t_{V(MO)}$	Data output valid time	—	—	—	5	ns
$t_{H(MO)}$	Data output hold time	—	2	—	—	ns
$t_{SU(MI)}$	Data input setup time	—	5	—	—	ns
$t_{H(MI)}$	Data input hold time	—	5	—	—	ns
<b>SPI Slave mode</b>						
$t_{SU(SEL)}$	SEL enable setup time	—	$4 t_{PCLK}$	—	—	ns
$t_{H(SEL)}$	SEL enable hold time	—	$2 t_{PCLK}$	—	—	ns
$t_{A(SO)}$	Data output access time	—	—	—	$3 t_{PCLK}$	ns
$t_{DIS(SO)}$	Data output disable time	—	—	—	10	ns
$t_{V(SO)}$	Data output valid time	—	—	—	25	ns
$t_{H(SO)}$	Data output hold time	—	15	—	—	ns
$t_{SU(SI)}$	Data input setup time	—	5	—	—	ns
$t_{H(SI)}$	Data input hold time	—	4	—	—	ns



**Figure 9. SPI Timing Diagrams – SPI Master Mode**

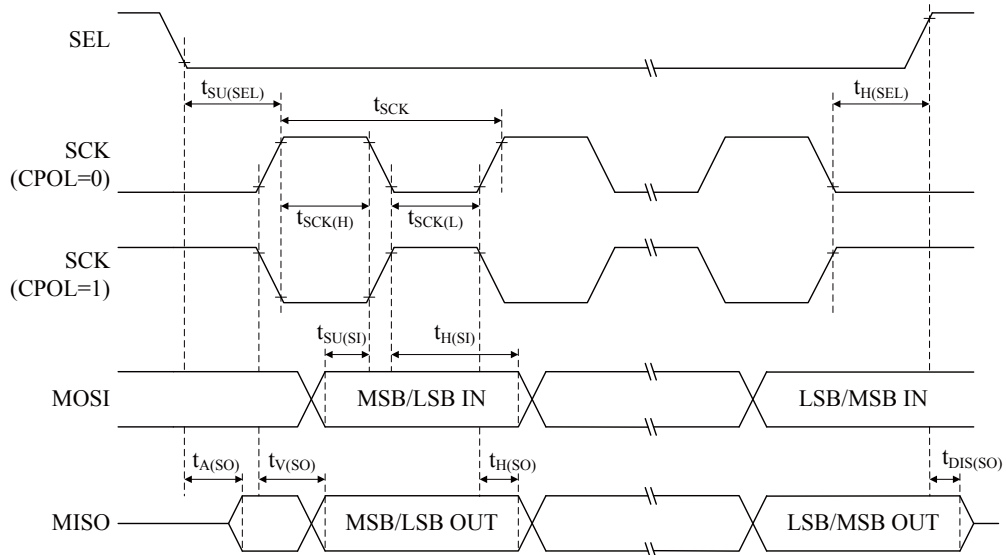

**Figure 10. SPI Timing Diagrams – SPI Slave Mode and CPHA=1**

## CSIF Characteristics

**Table 20. CSIF Characteristics**

Symbol	Parameter	Conditions	Min	Typ	Max	Unit
$f_{MCK}$	CSIF_MCK clock frequency output	—	—	—	36	MHz
$f_{PCK}$	CSIF_PCK clock frequency input	—	—	—	24	MHz
$r_F$	APB clock and CSIF_PCK clock input frequency ratio	$f_{PCLK}/f_{PCK}$	—	—	3	—

## USB Characteristics

The USB interface is USB-IF certified – Full Speed.

**Table 21. USB DC Electrical Characteristics**

Symbol	Parameter	Conditions	Min	Typ	Max	Unit
V <sub>DD</sub>	USB Operating voltage	—	3.0	—	3.6	V
V <sub>DI</sub>	Differential input sensitivity	USBDP-USBDM	0.2	—	—	V
V <sub>CM</sub>	Common mode voltage range	—	0.8	—	2.5	V
V <sub>SE</sub>	Single-ended receiver threshold	—	0.8	—	2.0	V
V <sub>OL</sub>	Pad output low voltage	R <sub>L</sub> of 1.5kΩ to V <sub>DD</sub>	0	—	0.3	V
V <sub>OH</sub>	Pad output high voltage		2.8	—	3.6	V
V <sub>CRS</sub>	Differential output signal cross-point voltage	—	1.3	—	2.0	V
Z <sub>DRV</sub>	Driver output resistance	—	—	10	—	Ω
C <sub>IN</sub>	Transceiver pad capacitance	—	—	—	20	pF

- NOTES:**
1. Guaranteed by design, not tested in production.
  2. To be compliant with the USB 2.0 full-speed electrical specification, the USBDP pin should be pulled up with a 1.5kΩ external resistor to a 3.0 to 3.6V voltage supply.
  3. The USB functionality is ensured down to 2.7V but not the full USB electrical characteristics which will experience degradation in the 2.7 to 3.0V V<sub>DD</sub> voltage range.
  4. R<sub>L</sub> is the load connected to the USB driver USBDP.

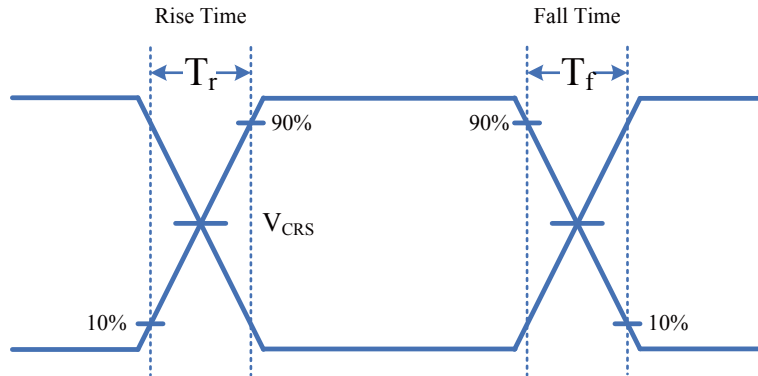

**Figure 11. USB Signal Rise Time and Fall time and Cross-Point Voltage ( $V_{CRS}$ ) Definition**

**Table 22. USB AC Electrical Characteristics**

Symbol	Parameter	Conditions	Min	Typ	Max	Unit
$T_r$	Rise time	$C_L = 50\text{pF}$	4	—	20	ns
$T_f$	Fall time	$C_L = 50\text{pF}$	4	—	20	ns
$T_{rff}$	Rise time / fall time matching	$T_{rff} = T_r / T_f$	90	—	110	%



## 5 Package Information

Note that the package information provided here is for consultation purposes only. As this information may be updated at regular intervals users are reminded to consult the Holtek website (<http://www.holtek.com.tw/english/literature/package.pdf>) for the latest version of the package information.

### 48-pin LQFP (7mm×7mm) Outline Dimensions

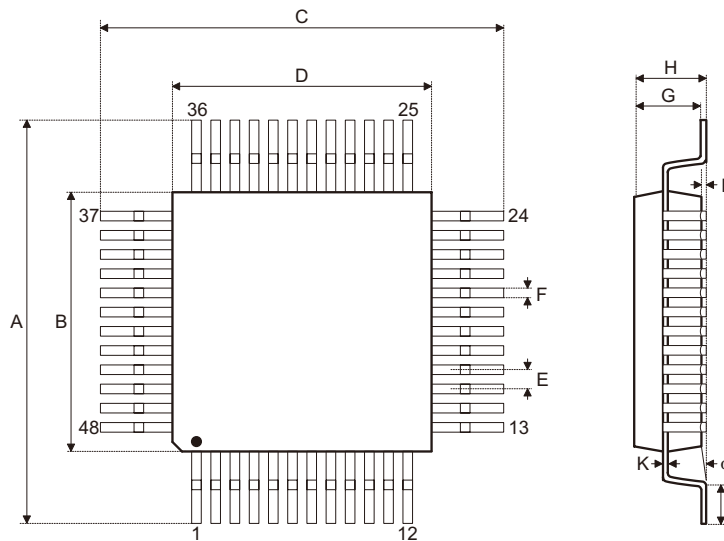

Symbol	Dimensions in inch		
	Min.	Nom.	Max.
A	0.350	—	0.358
B	0.272	—	0.280
C	0.350	—	0.358
D	0.272	—	0.280
E	—	0.020	—
F	—	0.008	—
G	0.053	—	0.057
H	—	—	0.063
I	—	0.004	—
J	0.018	—	0.030
K	0.004	—	0.008
$\alpha$	0°	—	7°

Symbol	Dimensions in mm		
	Min.	Nom.	Max.
A	8.90	—	9.10
B	6.90	—	7.10
C	8.90	—	9.10
D	6.90	—	7.10
E	—	0.50	—
F	—	0.20	—
G	1.35	—	1.45
H	—	—	1.60
I	—	0.10	—
J	0.45	—	0.75
K	0.10	—	0.20
$\alpha$	0°	—	7°

## 64-pin LQFP (7mm×7mm) Outline Dimensions

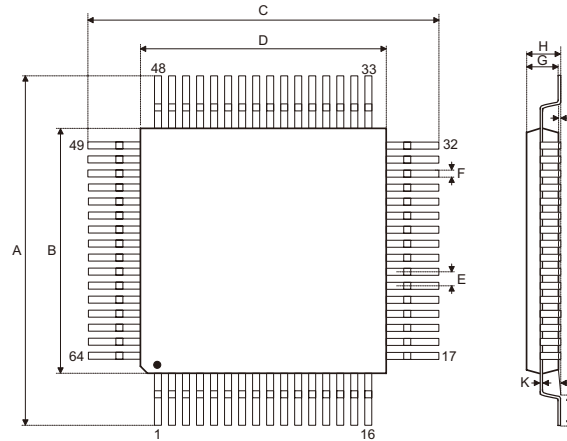

Symbol	Dimensions in inch		
	Min.	Nom.	Max.
A	0.350	—	0.358
B	0.272	—	0.280
C	0.350	—	0.358
D	0.272	—	0.280
E	—	0.016	—
F	0.005	—	0.009
G	0.053	—	0.057
H	—	—	0.063
I	0.002	—	0.006
J	0.018	—	0.030
K	0.004	—	0.008
$\alpha$	0°	—	7°

Symbol	Dimensions in mm		
	Min.	Nom.	Max.
A	8.90	—	9.10
B	6.90	—	7.10
C	8.90	—	9.10
D	6.90	—	7.10
E	—	0.40	—
F	0.13	—	0.23
G	1.35	—	1.45
H	—	—	1.60
I	0.05	—	0.15
J	0.45	—	0.75
K	0.09	—	0.20
$\alpha$	0°	—	7°

## 100-pin LQFP (14mm×14mm) Outline Dimensions

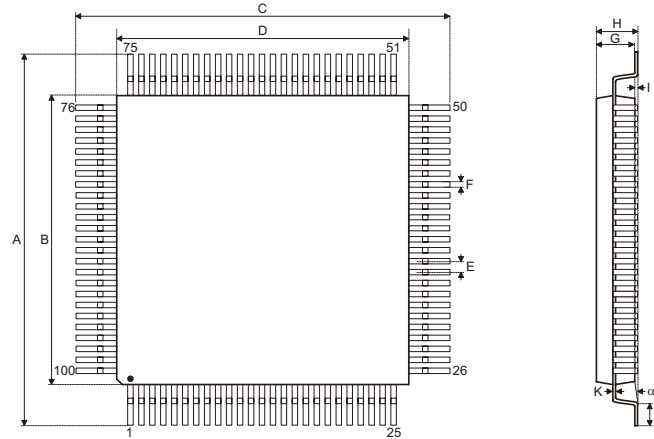

Symbol	Dimensions in inch		
	Min.	Nom.	Max.
A	0.626	—	0.634
B	0.547	—	0.555
C	0.626	—	0.634
D	0.547	—	0.555
E	—	0.020	—
F	—	0.008	—
G	0.053	—	0.057
H	—	—	0.063
I	—	0.004	—
J	0.018	—	0.030
K	0.004	—	0.008
$\alpha$	0°	—	7°

Symbol	Dimensions in mm		
	Min.	Nom.	Max.
A	15.90	—	16.10
B	13.90	—	14.10
C	15.90	—	16.10
D	13.90	—	14.10
E	—	0.50	—
F	—	0.20	—
G	1.35	—	1.45
H	—	—	1.60
I	—	0.10	—
J	0.45	—	0.75
K	0.10	—	0.20
$\alpha$	0°	—	7°

**Holtek Semiconductor Inc. (Headquarters)**

No.3, Creation Rd. II, Science Park, Hsinchu, Taiwan  
Tel: 886-3-563-1999  
Fax: 886-3-563-1189  
<http://www.holtek.com.tw>

**Holtek Semiconductor Inc. (Taipei Sales Office)**

4F-2, No. 3-2, YuanQu St., Nankang Software Park, Taipei 115, Taiwan  
Tel: 886-2-2655-7070  
Fax: 886-2-2655-7373  
Fax: 886-2-2655-7383 (International sales hotline)

**Holtek Semiconductor Inc. (Shenzhen Sales Office)**

5F, Unit A, Productivity Building, No.5 Gaoxin M 2nd Road, Nanshan District, Shenzhen, China 518057  
Tel: 86-755-8616-9908, 86-755-8616-9308  
Fax: 86-755-8616-9722

**Holtek Semiconductor (USA), Inc. (North America Sales Office)**

46729 Fremont Blvd., Fremont, CA 94538, USA  
Tel: 1-510-252-9880  
Fax: 1-510-252-9885  
<http://www.holtek.com>

Copyright© 2012 by HOLTEK SEMICONDUCTOR INC.

The information appearing in this Data Sheet is believed to be accurate at the time of publication. However, Holtek assumes no responsibility arising from the use of the specifications described. The applications mentioned herein are used solely for the purpose of illustration and Holtek makes no warranty or representation that such applications will be suitable without further modification, nor recommends the use of its products for application that may present a risk to human life due to malfunction or otherwise. Holtek's products are not authorized for use as critical components in life support devices or systems. Holtek reserves the right to alter its products without prior notification. For the most up-to-date information, please visit our web site at <http://www.holtek.com.tw>.