



TO-220AC

Features

- ✦ Glass passivated chip junction.
- ✦ High efficiency, Low VF
- ✦ High current capability
- ✦ High reliability
- ✦ High surge current capability
- ✦ For use in low voltage, high frequency inverter, free wheeling, and polarity protection application.

Mechanical Data

- ✦ Cases: TO-220AC Molded plastic
- ✦ Epoxy: UL 94V-0 rate flame retardant
- ✦ Polarity: As marked
- ✦ High temperature soldering guaranteed:
260°C/10 seconds .16", (4.06mm) from case.
- ✦ Weight: 2.24 grams

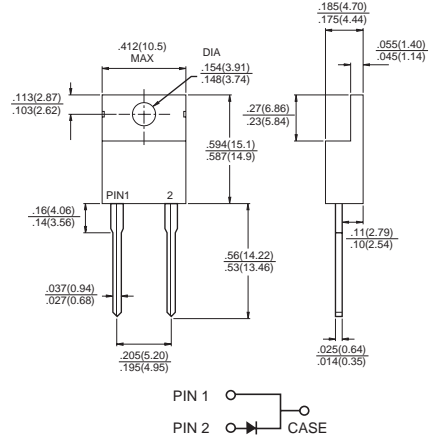

Dimensions in inches and (millimeters)

Maximum Ratings and Electrical Characteristics

Rating at 25 °C ambient temperature unless otherwise specified.

Single phase, half wave, 60 Hz, resistive or inductive load.

For capacitive load, derate current by 20%

Type Number	Symbol	HERA 1601G	HERA 1602G	HERA 1603G	HERA 1604G	HERA 1605G	HERA 1606G	HERA 1607G	HERA 1608G	Units
Maximum Recurrent Peak Reverse Voltage	V_{RRM}	50	100	200	300	400	600	800	1000	V
Maximum RMS Voltage	V_{RMS}	35	70	140	210	280	420	560	700	V
Maximum DC Blocking Voltage	V_{DC}	50	100	200	300	400	600	800	1000	V
Maximum Average Forward Rectified Current @ $T_C = 100^\circ C$	$I_{(AV)}$	16								A
Peak Forward Surge Current, 8.3 ms Single Half Sine-wave Superimposed on Rated Load (JEDEC method)	I_{FSM}	250								A
Maximum Instantaneous Forward Voltage @ 16.0A	V_F	1.0		1.3		1.7			V	
Maximum DC Reverse Current @ $T_A = 25^\circ C$ at Rated DC Blocking Voltage @ $T_A = 125^\circ C$	I_R	10 400								 uA uA
Maximum Reverse Recovery Time (Note 1)	T_{rr}	50					80			nS
Typical Junction Capacitance (Note 2)	C_j	120					80			pF
Typical Thermal Resistance (Note 3)	$R_{\theta JC}$	2.0								$^\circ C/W$
Operating Temperature Range	T_J	-65 to +150								$^\circ C$
Storage Temperature Range	T_{STG}	-65 to +150								$^\circ C$

- Notes:
1. Reverse Recovery Test Conditions: $I_F = 0.5A$, $I_R = 1.0A$, $I_{RR} = 0.25A$
 2. Measured at 1 MHz and Applied Reverse Voltage of 4.0V D. C.
 3. Mounted on Heatsink Size of 2 in x 3 in x 0.25 in Al-Plate.

RATINGS AND CHARACTERISTIC CURVES (HERA1601G THRU HERA1608G)

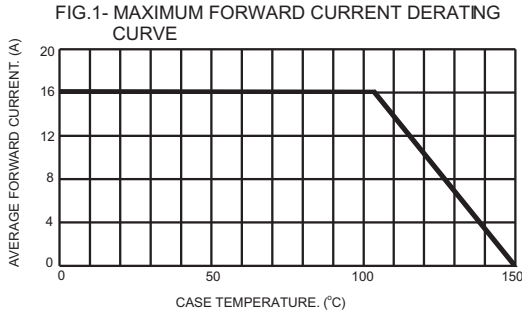

FIG.2- TYPICAL REVERSE CHARACTERISTICS

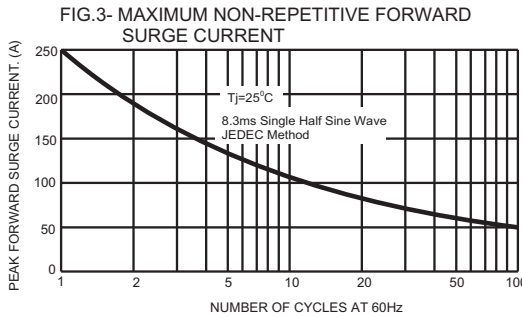
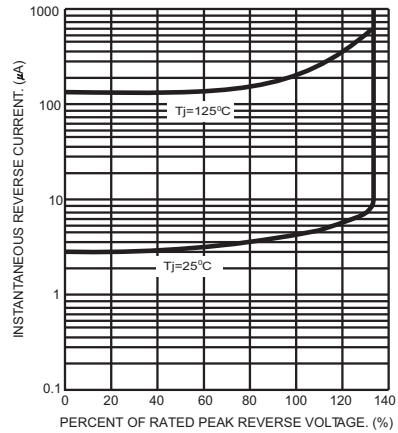

FIG.5- TYPICAL FORWARD CHARACTERISTICS

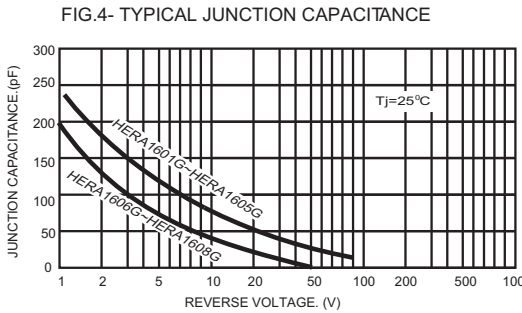
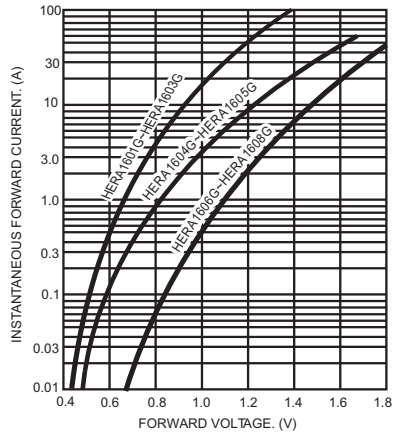

FIG.6- REVERSE RECOVERY TIME CHARACTERISTIC AND TEST CIRCUIT DIAGRAM

