



TEA2025

LINEAR INTEGRATED CIRCUIT

STEREO AUDIO AMPLIFIER

DESCRIPTION

The UTC TEA2025 is a monolithic integrated audio amplifier in a 16-pin plastic dual in line package. It is designed for portable cassette players and radios.

FEATURES

- *Working Voltage down to 3V
- *Few External components
- *High Channel isolation
- *Voltage gain up to 45dB(Adjustable with external resistor)
- *Soft clipping
- *Internal Thermal protection

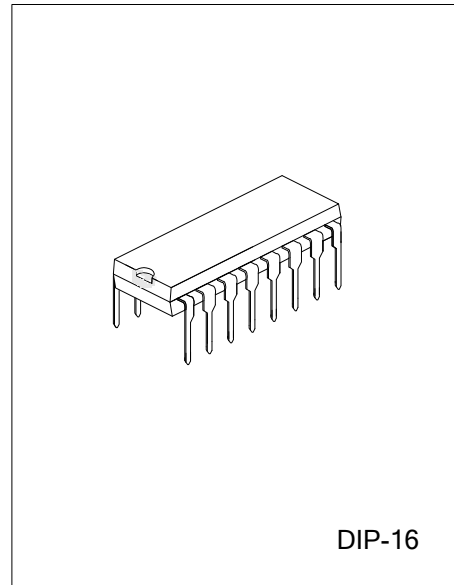

*Pb-free plating product number: TEA2025L

ORDERING INFORMATION

Order Number		Package	Packing
Normal	Lead Free Plating		
TEA2025-D16-T	TEA2025L-D16-T	DIP-16	Tube

PIN CONFIGURATION

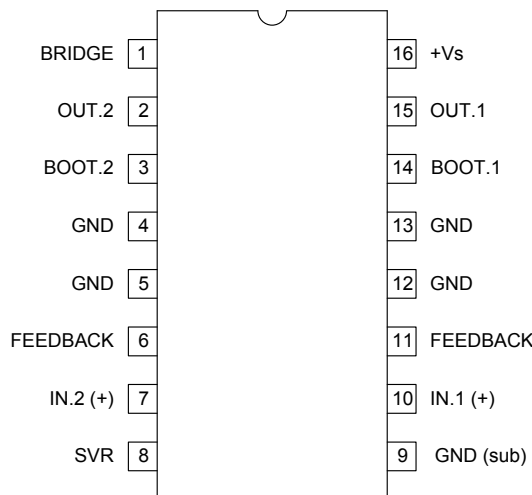

■ BLOCK DIAGRAM

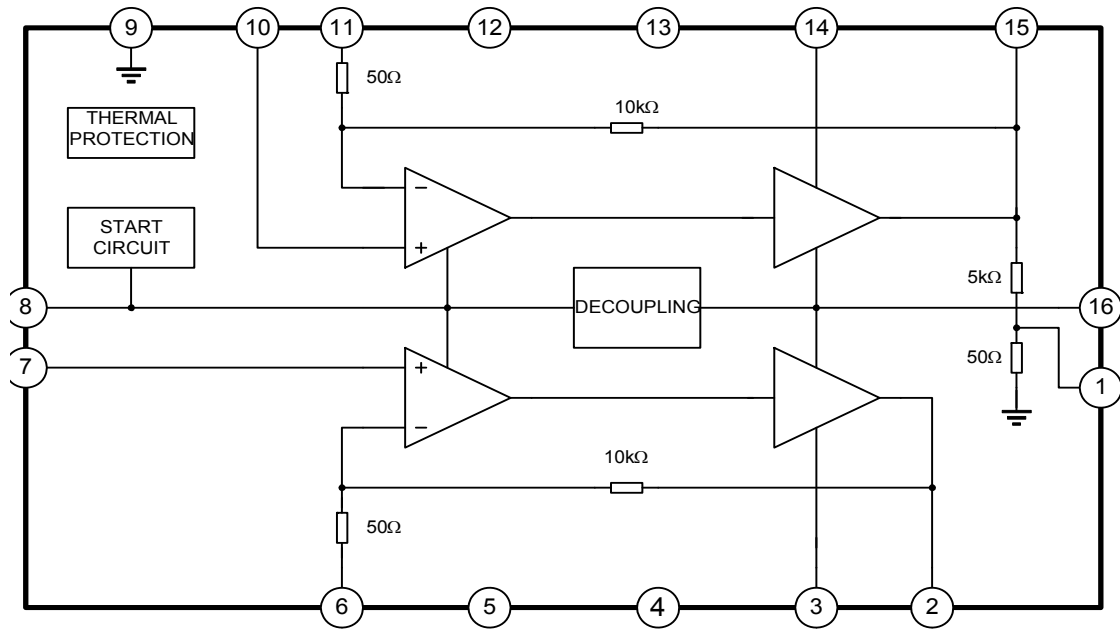

■ ABSOLUTE MAXIMUM RATINGS (Ta = 25°C)

PARAMETER	SYMBOL	RATINGS	UNIT
Supply Voltage	V _{SS}	15	V
Peak Output Current	I _{O (peak)}	1.5	A
Junction Temperature	T _J	150	°C
Operating Temperature	T _{OPR}	-20 ~ +85	°C
Storage Temperature	T _{STG}	-40 ~ +150	°C

Note 1. Absolute maximum ratings are those values beyond which the device could be permanently damaged.

Absolute maximum ratings are stress ratings only and functional device operation is not implied.

2. The device is guaranteed to meet performance specification within 0°C~70°C operating temperature range and assured by design from -20°C~85°C.

■ ELECTRICAL CHARACTERISTICS (Ta=25°C, V_{CC}=9V, Stereo, unless otherwise specified.)

PARAMETER	SYMBOL	TEST CONDITIONS	MIN	TYP	MAX	UNIT	
Supply Voltage	V _{SS}		3		12	V	
Quiescent Current	I _Q			40	50	mA	
Quiescent Output Voltage	V _{OUT}			4.5		V	
Voltage Gain	G _V	Stereo	43	45	47	dB	
		Bridge	49	51	53		
Voltage Gain Difference	ΔG _V				+1	dB	
Input Impedance	R _{IN}			30		kΩ	
Output Power	R _L =4Ω	P _{OUT}	f=1kHz, THD=10%, V _{CC} =9V Stereo per channel	1.7	2.3		W
	R _L =8Ω				1.3		
	R _L =4Ω		V _{CC} =6V	0.7	1		
	R _L =8Ω		V _{CC} =3V		0.6		
	R _L =4Ω		Bridge, V _{CC} =9V		4.7		
	R _L =8Ω		V _{CC} =6V		2.8		
	R _L =4Ω		V _{CC} =6V		2.8		
Total Harmonic Distortion	Stereo	THD	V _{CC} =9V, R _L =4Ω, f=1kHz, P _{OUT} =250mW	0.3	1.5	%	
	Bridge			0.5			
Supply Voltage Rejection	SVR	R _G =0, AV=45Db, V _{RIPPLE} =150mV F _{RIPPLE} =100Hz	40	46		dB	
Input Noise Voltage	R _G =0	V _n	A _V =200, Bandwidth:20Hz ~ 20kHz	1.5	3	μV	
	R _G =10kΩ			3	6		
Cross-Talk	C.T.	R _G =10kΩ, f=1kHz, R _L =4Ω, P _{OUT} =1W	40	55		dB	

■ THERMAL CHARACTERISTICS

PARAMETER	SYMBOL	RATINGS	UNIT
Thermal Resistance Junction to ambient	θ _{JA}	60	°C/W
Thermal Resistance Junction to case	θ _{JC}	15	

■ APPLICATION INFORMATION

Input Capacitor

Input capacitor is PNP type allowing source to be referenced to ground. In this way no input coupling capacitor is required. However, a series capacitor (0.22 uF) to the input side can be useful in case of noise due to variable resistor contact.

Bootstrap

The bootstrap connection allows to increase the output swing. The suggested value for the bootstrap capacitors (100uF) avoids a reduction of the output signal also at low frequencies and low supply voltages.

Voltage Gain Adjust

STEREO MODE (Figure 1)

The voltage gain is determined by on-chip resistors R1 and R2 together with the external RfC1 series connected between pin 6 (11) and ground. The frequency response is given approximated by:

$$\frac{V_{OUT}}{V_{IN}} = \frac{R_1}{R_f + R_2 + \frac{1}{j\omega C_1}}$$

With $R_f=0$, $C_1=100\mu\text{F}$, the gain results 46 dB with pole at $f=32$ Hz.

THE purpose of Rf is to reduce the gain. It is recommended to not reduce it under 36 dB.

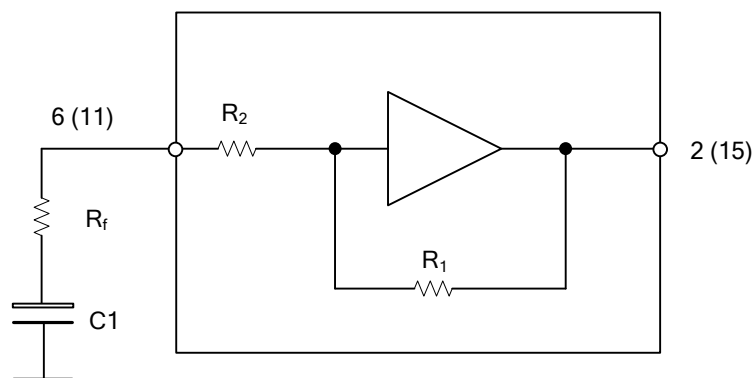

Figure 1

BRIDGE MODE (Figure 2)

The bridge configuration is realized very easily thanks to an internal voltage divider which provides (at pin 1) the CH 1 output signal after reduction. It is enough to connect pin 6 (inverting input of CH 2) with a capacitor to pin 1 and to connect to ground the pin 7.

The total gain of the bridge is given by:

$$\frac{V_{OUT}}{V_{IN}} = \frac{R_1}{R_f + R_2 + \frac{1}{j\omega C_1}} \left(1 + \frac{R_3}{R_4} \frac{R_1}{R_2 + R_4 + \frac{1}{j\omega C_1}} \right)$$

and with the suggested values ($C_1 = C_2 = 100$ uF, $R_f = 0$) means: $G_v = 52$ dB with first pole at $f = 32$ Hz

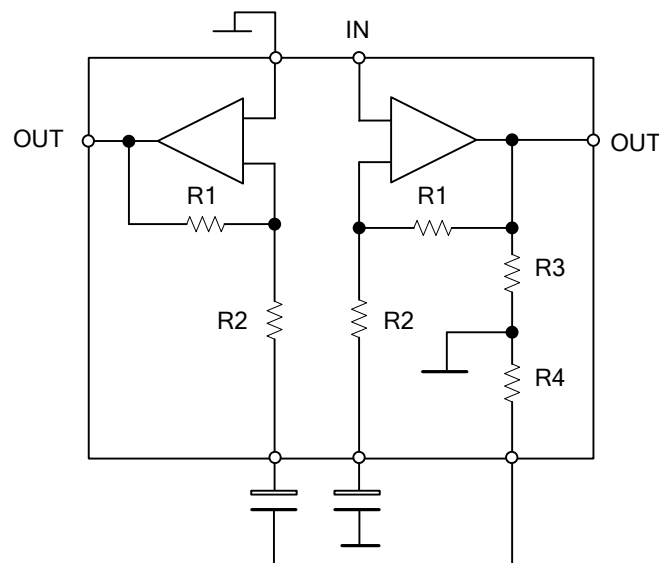

Figure 2

Output Capacitors

The low cut off frequency due to output capacitor depending on the load is given by:

$$F_L = \frac{1}{2\pi C_{OUT} \times R_L}$$

with $C_{OUT} = 470\mu\text{F}$ and $R_L = 4\ \Omega$ it means $F_L = 80\text{Hz}$.

Pop Noise (Figure 3)

Most amplifiers similar to UTC **TEA2025** need external resistors between DC outputs and ground in order to optimize the pop on/off performance and crossover distortion.

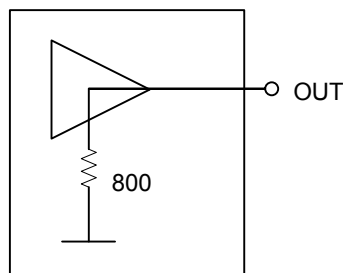

Figure 3

The UTC **TEA2025** solution allows to save components because of such resistors (800 ohm) are included into the chip.

Stability

A good layout is recommended in order to avoid oscillations. Generally the designer must pay attention on the following points:

- Short wires of components and short connections.
- No ground loops.
- Bypass of supply voltage with capacitors as nearest as possible to the supply I. C. pin. The low value (polyester) capacitors must have good temperature and frequency characteristics.
- No sockets.

The heatsink can have a smaller factor of safety compared with that of a conventional circuit. There is no device damage in the case of excessive junction temperature: all that happens is that P_O (and therefore P_{tot}) and I_d are reduced.

TYPICAL APPLICATION CIRCUIT

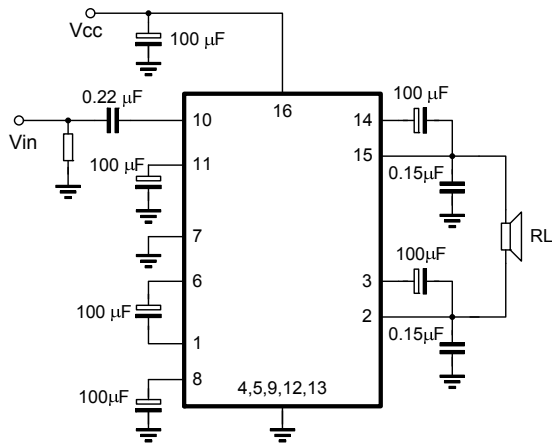

Fig. 4 Bridge Application

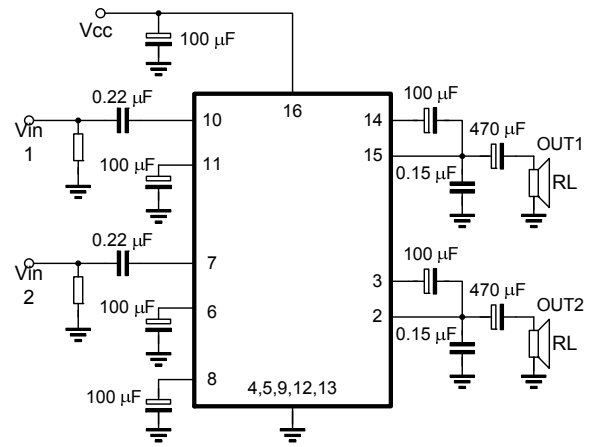
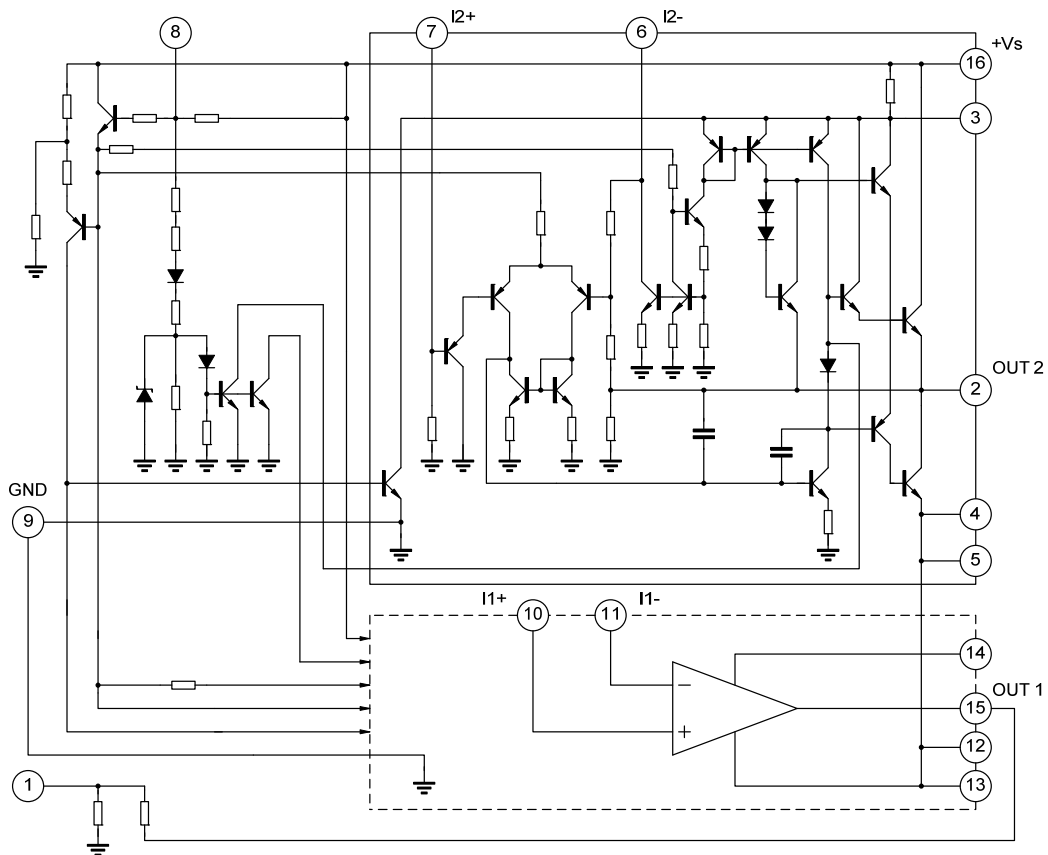
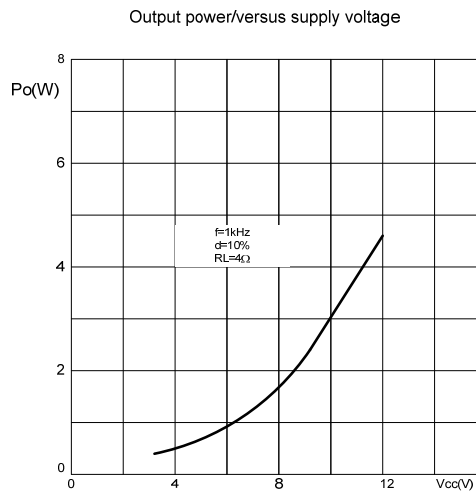
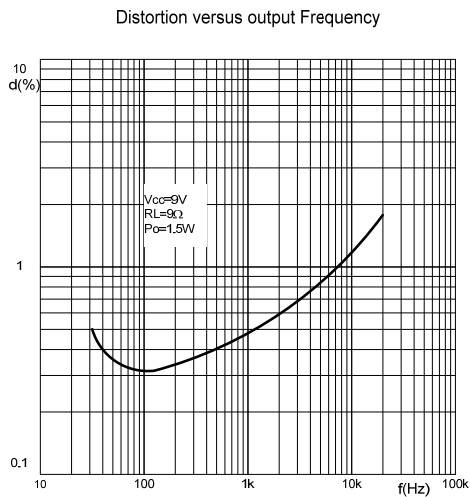
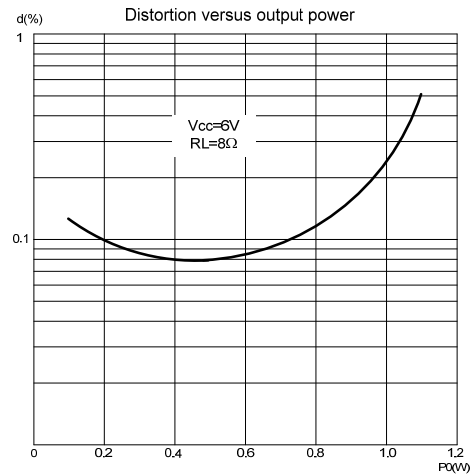
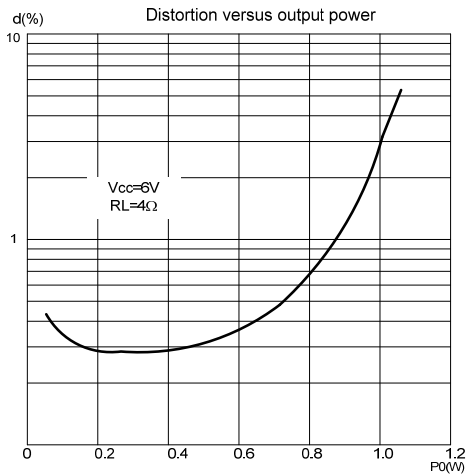

Fig. 5 Stereo Application

SCHEMATIC DIAGRAM



■ TYPICAL CHARACTERISTICS



UTC assumes no responsibility for equipment failures that result from using products at values that exceed, even momentarily, rated values (such as maximum ratings, operating condition ranges, or other parameters) listed in products specifications of any and all UTC products described or contained herein. UTC products are not designed for use in life support appliances, devices or systems where malfunction of these products can be reasonably expected to result in personal injury. Reproduction in whole or in part is prohibited without the prior written consent of the copyright owner. The information presented in this document does not form part of any quotation or contract, is believed to be accurate and reliable and may be changed without notice.