

# The Fujitsu MB86064 and MB86065 High-Performance Digital to Analog Converters

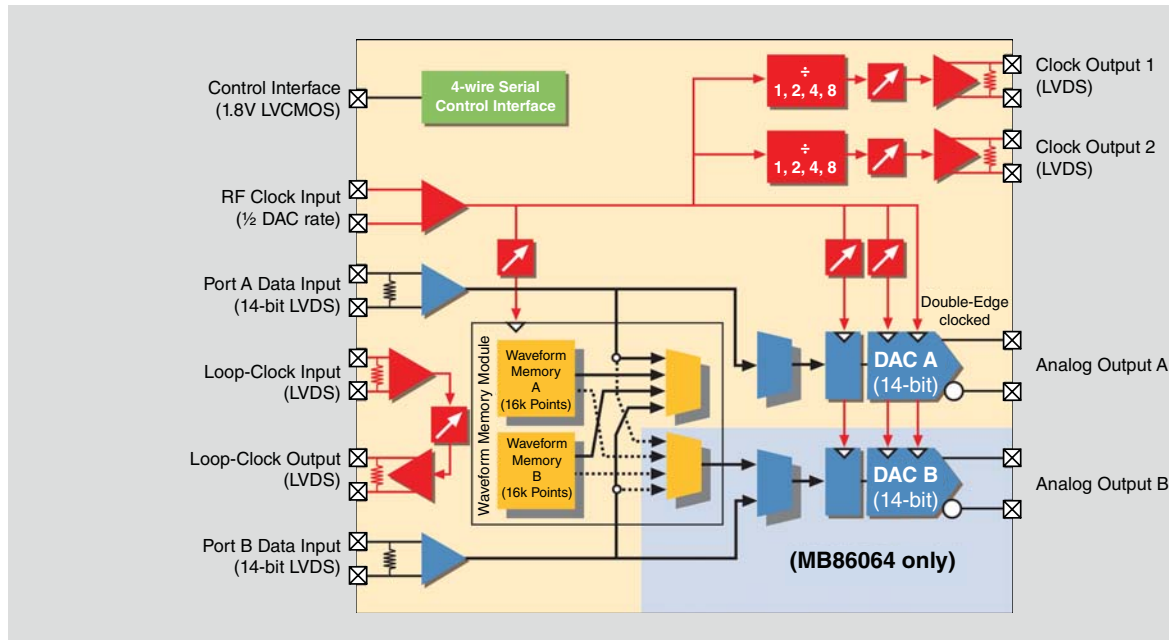

## Description

The MB86064 and MB86065 are part of the Fujitsu second generation of high-performance digital to analog converters (DACs).

- MB86064 Dual 14-bit 1.0GSa/s DAC
- MB86065 Single 14-bit 1.3GSa/s DAC

The MB86064 is ideally suited to radio applications, providing dual transmit or transmit with diversity. The MB86065 supports conversion rates up to 1.3GSa/s, which enables higher generating frequencies combined with wider spurious-free generating regions.

## Features

- Delivers higher frequency, direct-IF generation compared to competitors' alternatives
- Avoids the analog and digital overhead of IQ and direct conversion architectures
- Supports multiple, including non-contiguous, narrow and wide-band signal generation
- Integrated waveform memory for storing test and evaluation vectors on-chip

Both devices feature the market's shortest propagation delay combined with superior time-domain response for control-based applications that require low latency.

Robust data interfacing to compatible FPGAs and ASICs is assured by a proprietary Loop-Clock architecture. This unique solution automatically maintains critical clock-to-data timing across variations in process, voltage and temperature (PVT). No calibration is required during production or lifetime operation, reducing total system costs.

# The Fujitsu MB86064 and MB86065 DACs

## ► Applications

- Radio communications and test systems, e.g., UMTS, LTE and WiMAX 802.16, UWB wideband and multi-carrier systems
- Doherty amplifiers
- Remote Radio Heads (RRHs)
- Linear power amplifiers employing crest factor reduction and digital pre-distortion
- Cable modem multi-channel DRFI 16-ch DOCSIS or 12-ch EuroDOCSIS 64 and 256 QAM
- Medical and technology laser drive circuits
- Pulsed and arbitrary waveform generation
- Semiconductor scribing, dicing and drilling
- Low-latency digital control systems, e.g., particle accelerator electromagnets
- Medical and test instrumentation

## ► Development Kit

The development kit includes everything needed to minimize start-up time:

- Evaluation board
- PC-USB interface
- PC software utility



DK86064-2 / DK86065-2

## ► Part Numbers

- MB86064PB-GE1
- MB86065PB-GE1

Both devices are RoHS 6/6 compliant.

## FUJITSU MICROELECTRONICS AMERICA, INC.

Corporate Headquarters  
1250 E. Arques Avenue, M/S 333, Sunnyvale, CA 94085-5401  
Tel: (800) 866-8608 Fax: (408) 737-5999  
E-mail: [inquiry@fma.fujitsu.com](mailto:inquiry@fma.fujitsu.com) Web Site: <http://us.fujitsu.com/micro>



© 2009 Fujitsu Microelectronics America, Inc.  
All company and product names are trademarks or registered trademarks of their respective owners.  
Printed in the U.S.A. EPS-FS-21354-11/2009