

Linear Systems replaces discontinued Siliconix 2N5019

The LS5019 is a single P-Channel JFET switch

This p-channel analog switch is designed to provide low on-resistance and fast switching.

The TO-92 provides a low cost option and ease of manufacturing.

(See Packaging Information).

LS5019 Benefits:

- Low Insertion Loss
- No offset or error voltage generated by closed switch
- Purely resistive

LS5019 Applications:

- Analog Switches
- Commutators
- Choppers

FEATURES

DIRECT REPLACEMENT FOR SILICONIX 2N5019

ZERO OFFSET VOLTAGE

LOW ON RESISTANCE

$r_{DS(on)} \leq 150\Omega$

ABSOLUTE MAXIMUM RATINGS
@ 25°C (unless otherwise noted)

Maximum Temperatures

Storage Temperature

-55°C to +200°C

Operating Junction Temperature

-55°C to +200°C

Maximum Power Dissipation

Continuous Power Dissipation

500mW

MAXIMUM CURRENT

Gate Current (Note 1)

$I_G = -50\text{mA}$

MAXIMUM VOLTAGES

Gate to Drain Voltage

$V_{GDS} = 30\text{V}$

Gate to Source Voltage

$V_{GSS} = 30\text{V}$

LS5019 ELECTRICAL CHARACTERISTICS @ 25°C (unless otherwise noted)

SYMBOL	CHARACTERISTIC	MIN	TYP.	MAX	UNITS	CONDITIONS
BV_{GSS}	Gate to Source Breakdown Voltage	30	--	--	V	$I_G = 1\mu\text{A}, V_{DS} = 0\text{V}$
$V_{GS(off)}$	Gate to Source Cutoff Voltage	--	--	5		$V_{DS} = -15\text{V}, I_D = -1\mu\text{A}$
$V_{DS(on)}$	Drain to Source On Voltage	--	--	-0.5		$V_{GS} = 0\text{V}, I_D = -3\text{mA}$
I_{DSS}	Drain to Source Saturation Current (Note 2)	-5	--	--	mA	$V_{DS} = -20\text{V}, V_{GS} = 0\text{V}$
I_{GSS}	Gate Reverse Current	--	--	2	nA	$V_{GS} = 15\text{V}, V_{DS} = 0\text{V}$
$I_{D(off)}$	Drain Cutoff Current	--	--	-10	μA	$V_{DS} = -15\text{V}, V_{GS} = 12\text{V}$
I_{DGO}	Drain Reverse Current	--	--	-2		$V_{DS} = -15\text{V}, V_{GS} = 7\text{V}$
$r_{DS(on)}$	Drain to Source On Resistance	--	--	150	Ω	$I_D = -1\text{mA}, V_{GS} = 0\text{V}$

LS5019 DYNAMIC ELECTRICAL CHARACTERISTICS @ 25°C (unless otherwise noted)

SYMBOL	CHARACTERISTIC	MIN	TYP.	MAX	UNITS	CONDITIONS
$r_{DS(on)}$	Drain to Source On Resistance	--	--	150	Ω	$I_D = 0\text{A}, V_{GS} = 0\text{V}, f = 1\text{kHz}$
C_{iss}	Input Capacitance	--	--	45	pF	$V_{DS} = -15\text{V}, V_{GS} = 0\text{V}, f = 1\text{MHz}$
C_{rss}	Reverse Transfer Capacitance	--	--	10		$V_{DS} = 0\text{V}, V_{GS} = 7\text{V}, f = 1\text{MHz}$

LS5019 SWITCHING CHARACTERISTICS @ 25°C (unless otherwise noted)

SYMBOL	CHARACTERISTIC	UNITS	CONDITIONS
$t_{d(on)}$	Turn On Time	15	ns
t_r	Turn On Rise Time	75	
$t_{d(off)}$	Turn Off Time	25	
t_f	Turn Off Fall Time	100	

See Switching Circuit

Note 1 - Absolute maximum ratings are limiting values above which LS5019 serviceability may be impaired.

Note 2 - Pulse test: $PW \leq 300\mu\text{s}$, Duty Cycle $\leq 3\%$

LS5019 SWITCHING CIRCUIT PARAMETERS

V_{DD}	-6V
V_{GG}	8V
R_L	1.8k Ω
R_G	390 Ω
$I_{D(on)}$	-3mA

Available Packages:

LS5019 in TO-92
LS5019 in bare die.

Please contact Micross for full package and die dimensions

TO-92 (Bottom View)

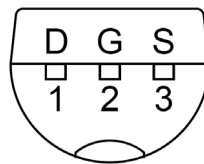

SWITCHING TEST CIRCUIT

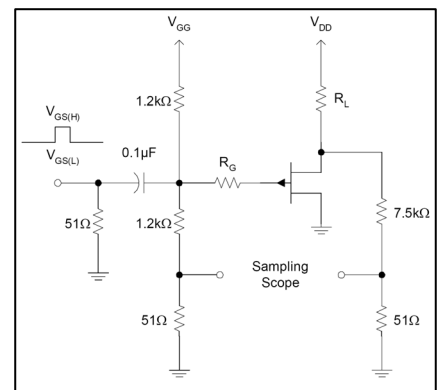

Micross Components Europe



Tel: +44 1603 788967

Email: chipcomponents@micross.com

Web: <http://www.micross.com/distribution>

Information furnished by Linear Integrated Systems and Micross Components is believed to be accurate and reliable. However, no responsibility is assumed for its use; nor for any infringement of patents or other rights of third parties which may result from its use. No license is granted by implication or otherwise under any patent or patent rights of Linear Integrated Systems.