

AM1N-N Series

1 watt dc-dc converters

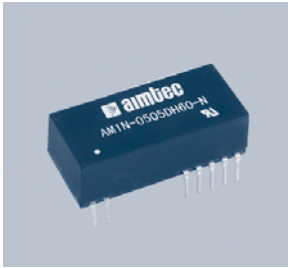

- 24-PIN DIP PACKAGE
- LOW PROFILE PLASTIC PACKAGE
- HIGH EFFICIENCY UP TO 81%
- UL94-VO PACKAGE
- INPUT/OUTPUT ISOLATION: 6000VDC
- OPERATING TEMPERATURE: -40°C ... +85°C
- PIN-COMPATIBLE WITH MULTIPLE MANUFACTURERS

GENERAL DESCRIPTION

Our AM1N-N series is a family of cost effective 1W single and dual output DC-DC converters. These converters combine plastic package in a 24-pin DIP compatible case with high performance feature such as 6000VDC input/output isolation voltage. Twenty four

models operate from input voltages of 5, 12 & 24VDC with output voltages of 5, 9, 12, 15, ± 5 , ± 9 , ± 12 , ± 15 VDC. Operation is specified over the full operating temperature range of -40°C to +85°C with no derating required. Cooling is by free-air convection.

ELECTRICAL SPECIFICATIONS

Specifications typical at +25°C, nominal input voltage, rated output current unless otherwise specified

Input Specifications:

Voltage range	$\pm 10\%$
Filter	Capacitor

Isolation Specifications:

Rated voltage (60 sec)	6000 VDC
Resistance	> 1000 MOhm

General Specifications:

Efficiency	72% to 81%
Switching Frequency	35 KHz, typ. 100% load

Physical Specifications

Dimensions	32.3x14.7x9.4 mm 1.27x0.58x0.37 inches
Weight	16 g
Case material	Plastic UL94-VO

Output Specifications:

Voltage accuracy	See tolerance envelope graph
Ripple & noise (at 20MHz BW)	75mVp-p, typ.
Short circuit protection	1 sec.
Line voltage regulation	$\pm 1.2\%/1\%$ of V_{in} max.
Load voltage regulation	10%, max.
Temperature Coefficient	$\pm 0.03\%/^{\circ}\text{C}$, max.

Environmental Specifications:

Operating temperature (ambient)	-40°C to +85°C
Storage temperature	-55°C to +125°C
Case temperature	+95°C, max.
Derating	None required
Humidity (non-condensing)	Up to 90%
Cooling	Free-air Convection

MTBF: > 1,211,000 hrs (MIL-HDBK-217F, Ground Benign, $t=+25^{\circ}\text{C}$)

Specifications are subject to change without notification

OUTLINE DIMENSIONS & PIN CONNECTIONS

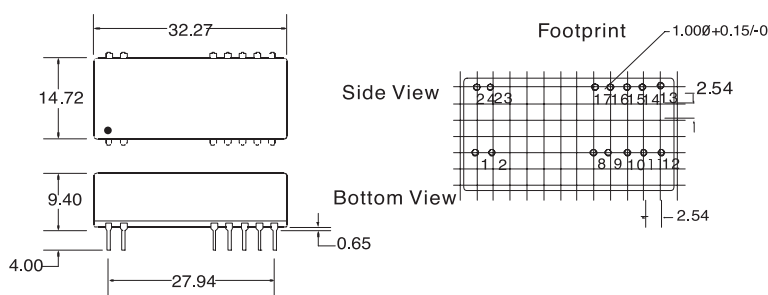

Note: All Pins on a 2.54mm pitch; all pin diameters are 0.50mm; all dimensions in mm.

Single output

Pin	Function
1	+V Input
2	-V Input
8,17	N.C.
10,15	OV
12,13	+V Output



Dual output

Pin	Function
1	+V Input
2	-V Input
8,17	-V Output
10,15	OV
12,13	+V Output



AM1N-N Series

MODELS Single output

Models	Input Voltage	Ouput Voltage	Ouput Current max.
AM1N-0505SH60-N	5V \pm 10%	5VDC	200mA
AM1N-0509SH60-N		9VDC	111mA
AM1N-0512SH60-N		12VDC	84mA
AM1N-0515SH60-N		15VDC	67mA
AM1N-1205SH60-N	12V \pm 10%	5VDC	200mA
AM1N-1209SH60-N		9VDC	111mA
AM1N-1212SH60-N		12VDC	84mA
AM1N-1215SH60-N		15VDC	67mA
AM1N-2405SH60-N	24V \pm 10%	5VDC	200mA
AM1N-2409SH60-N		9VDC	111mA
AM1N-2412SH60-N		12VDC	84mA
AM1N-2415SH60-N		15VDC	67mA

Dual output

Models	Input Voltage	Ouput Voltage	Ouput Current max.
AM1N-0505DH60-N	5V \pm 10%	5VDC	\pm 100mA
AM1N-0509DH60-N		9VDC	\pm 55mA
AM1N-0512DH60-N		12VDC	\pm 42mA
AM1N-0515DH60-N		15VDC	\pm 33mA
AM1N-1205DH60-N	12V \pm 10%	5VDC	\pm 100mA
AM1N-1209DH60-N		9VDC	\pm 55mA
AM1N-1212DH60-N		12VDC	\pm 42mA
AM1N-1215DH60-N		15VDC	\pm 33mA
AM1N-2405DH60-N	24V \pm 10%	5VDC	\pm 100mA
AM1N-2409DH60-N		9VDC	\pm 55mA
AM1N-2412DH60-N		12VDC	\pm 42mA
AM1N-2415DH60-N		15VDC	\pm 33mA

TYPICAL CHARACTERISTICS

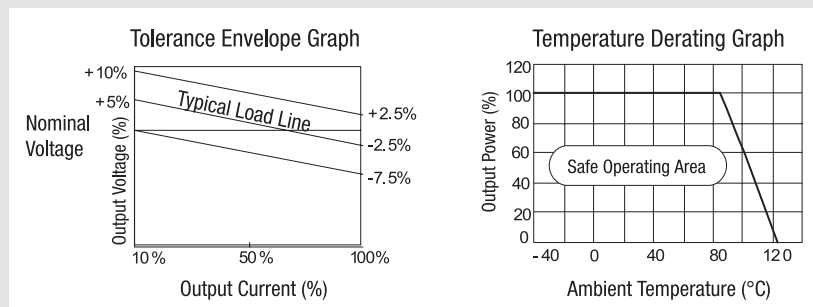

APPLICATION NOTE

Filtering

In some circuits which are sensitive to noise and ripple, a filtering capacitor may be added to the dc/dc output end and input end to reduce the noise and ripple. However, the capacitance of the output filter capacitor must be proper. If the capacitance is too big, a startup problem might arise. For every channel of output, provided the safe and reliable operation is ensured, the greatest capacitance of its filter capacitor sees the external capacitor table. To get an extremely low ripple, an "LC" filtering network may be connected to the input and output ends of the dc/dc converter, which may produce a more significant filtering effect. It should also be noted that the inductance and the frequency of the "LC" filtering network should be staggered with the dc/dc frequency to avoid mutual interference (see figure 1).

Requirement on output load

To ensure this module can operate efficiently and reliably, a minimum load is specified for this kind of dc/dc converter in addition to a maximum load (namely full load). During operation, make sure the specified range of input voltage is not exceeded, the minimum output load is not less than 10% of the full load, and that this product should never be operated under no load! If the actual output power is very small, please connect a resistor with proper resistance at the output end in parallel to increase the load.

For single output

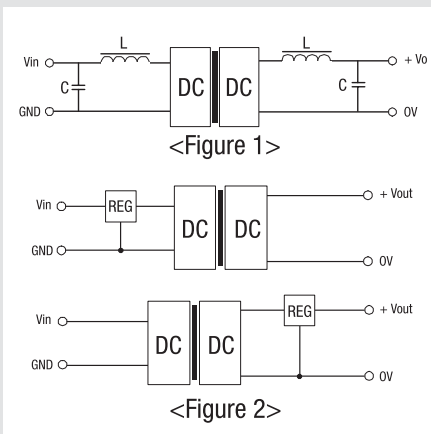

Overload Protection

Under normal operating conditions, the output circuit of these products has no protection against over-current and short-circuits. The simplest method is to connect a self-recovery fuse in series at the input end or add a circuit breaker to the circuit.

Output Voltage Regulation and Over-voltage Protection Circuit

The simplest device for output voltage regulation, over-voltage and over-current protection is a linear voltage stabilizer with overheat protection that is connected to the input or output end in series (see Figure 2).

For dual output

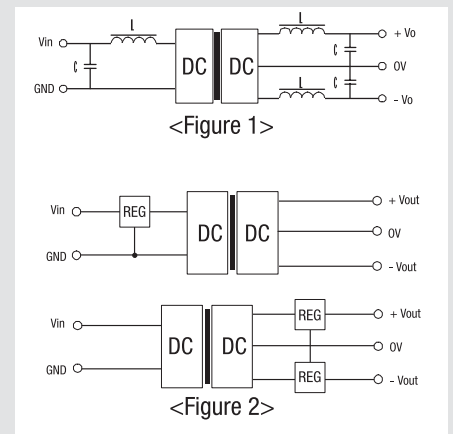

External Capacitor Table for Single Output

Vin	External Capacitor	Vout	External Capacitor
5VDC	4.7uF	5VDC	10uF
12VDC	2.2uF	9VDC	4.7uF
24VDC	1uF	12VDC	2.2uF
-	-	15VDC	1uF

External Capacitor Table for Dual Output

Vin	External Capacitor	Vout	External Capacitor
5VDC	4.7uF	5VDC	4.7uF
12VDC	2.2uF	9VDC	2.2uF
24VDC	1uF	12VDC	1uF
-	-	15VDC	0.47uF