



UC34163

LINEAR INTEGRATED CIRCUIT

DC TO DC CONVERTER CONTROLLER

DESCRIPTION

The UTC **UC34163** is a monolithic regulator subsystem, intended for use as DC-to-DC converter. This device contains a temperature compensated reference, 2 comparators, a duty-cycle control oscillator, driver and high current output switch.

FEATURES

- * Maximum input voltage is 35V.
- * Low standby current.
- * Output switch current to 1.5A.
- * Frequency of operation from 100Hz ~ 100kHz.
- * Step-down switch regulators.

ORDERING INFORMATION

Ordering Number		Package	Packing
Lead Free	Halogen Free		
UC34163L-D08-T	UC34163G-D08-T	DIP-8	Tube
UC34163L-S08-R	UC34163G-S08-R	SOP-8	Tape Reel
UC34163L-S08-T	UC34163G-S08-T	SOP-8	Tube

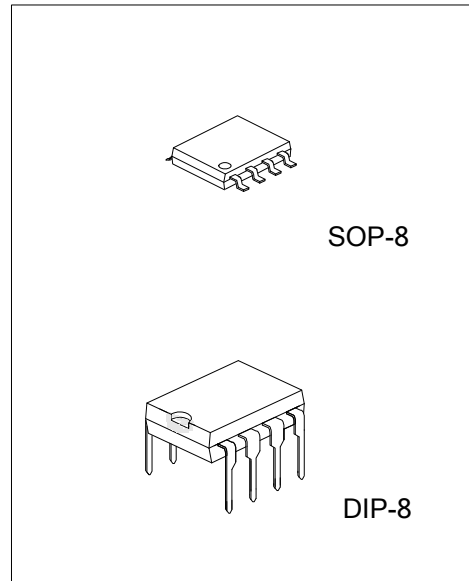

<p>UC34163L-D08-T</p> <p>(1)Packing Type (2)Package Type (3)Lead Free</p>	<p>(1) R: Tape Reel, T: Tube (2) D08: DIP-8, S08: SOP-8 (3) G: Halogen Free, L: Lead Free</p>
---	---

■ PIN CONFIGURATION

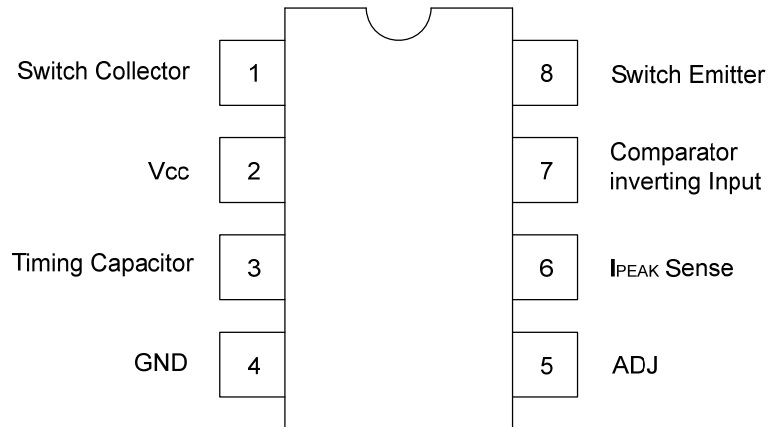

■ BLOCK DIAGRAM

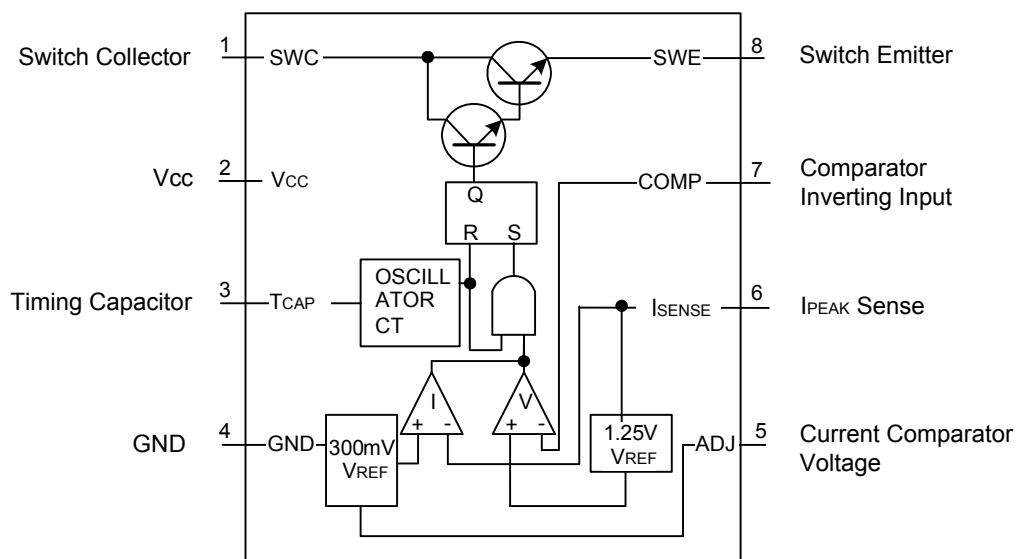

■ ABSOLUTE MAXIMUM RATINGS (Ta=25°C)

PARAMETER	SYMBOL	RATINGS	UNIT
Supply Voltage	V _{CC}	35	V
Comparator Input Voltage Range	V _{IN(COMP)}	-0.3 ~ +35	V
Switch Collector Voltage	V _{C(SW)}	35	V
Switch Emitter Voltage	V _{E(SW)}	35	V
Switch Collector To Emitter Voltage	V _{CE(SW)}	35	V
Output Switch Current	I _{OUT}	1.5	A
Power Dissipation (Ta=25°C)	DIP-8	1250	mW
	SOP-8	625	mW
Operating Junction Temperature	T _J	+125	°C
Operating Temperature	T _{OPR}	-20 ~ +85	°C
Storage Temperature	T _{STG}	-40 ~ +150	°C

Note: 1. Absolute maximum ratings are those values beyond which the device which the device could be permanently damaged. Absolute maximum ratings are stress ratings only and functional device operation is not implied.

2. The device is guaranteed to meet performance specification within 0°C~+70°C operating temperature range and assured by design from -20°C~+85°C, characteristic and correlation with static process control.

■ THERMAL DATA

PARAMETER	SYMBOL	RATINGS	UNIT
Junction to Case	DIP-8	100	°C/W
	SOP-8	160	

■ ELECTRICAL CHARACTERISTICS (Ta=25°C, V_{CC} = 5.0V, Ta=0 ~ 70°C, unless otherwise specified.)

PARAMETER	SYMBOL	TEST CONDITIONS	MIN	TYP	MAX	UNIT
Oscillator						
Frequency (C _T =470pF, Ta=25°C)	F _{OSC}		25	35	45	kHz
Charging Current	I _{CHG}	V _{CC} =5 ~ 35V, Ta=25°C	20	30	40	μA
Discharging Current	I _{DISCHG}	V _{CC} =5 ~ 35V, Ta=25°C	140	200	260	μA
Oscillator Amplitude	V _{OSC}	Ta=25°C		0.8		V
Discharge to Charge Current Ratio	K	Ta=25°C	5.2		8.0	
Output Switch						
Saturation Voltage 1(Note1)	V _{CE(SAT)}	I _{SW} =1.0A			1.4	V
Collector Off State Current (Note1)	I _{C(OFF)}	V _{CE} =35.0V, Ta=25°C		0.01	100	μA
ADJ						
Current limit Sense Voltage	V _{SENSE}		280	300	360	mV
Comparator						
Threshold Voltage 1	V _{THD1}		1.21	1.24	1.29	V
Threshold Voltage 2	V _{THD2}		280	300	360	mV
Threshold Voltage Line Regulation	ΔV _{THD1}	V _{CC} =5 ~ 35V		2.0	5.0	mV
Input Bias Current	I _{BIAS}	V _{IN} =0V		50	400	nA
Total Device						
Supply Current	I _{CC}	V _{CC} =5 ~ 35V, C _T =470pF V ₆ =GND, V ₇ >V _{THD1}		2.5	4.0	mA

Note1: Output switch tests are performed under pulsed conditions to minimize power dissipation.

■ TYPICAL APPLICATION CIRCUIT

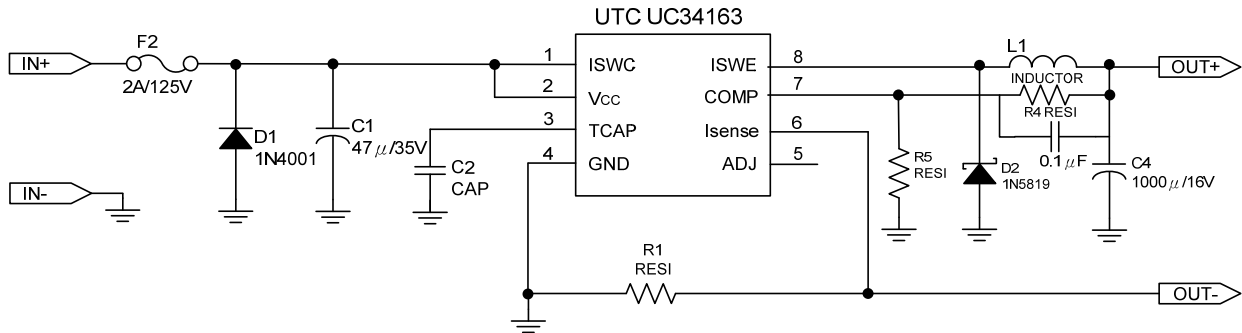

UTC assumes no responsibility for equipment failures that result from using products at values that exceed, even momentarily, rated values (such as maximum ratings, operating condition ranges, or other parameters) listed in products specifications of any and all UTC products described or contained herein. UTC products are not designed for use in life support appliances, devices or systems where malfunction of these products can be reasonably expected to result in personal injury. Reproduction in whole or in part is prohibited without the prior written consent of the copyright owner. The information presented in this document does not form part of any quotation or contract, is believed to be accurate and reliable and may be changed without notice.