

# Freescale Semiconductor

## Integrated Silicon Pressure Sensor On-Chip Signal Conditioned, Temperature Compensated and Calibrated

The MPXV7025 series piezoresistive transducer is a state-of-the-art monolithic silicon pressure sensor designed for a wide range of applications, but particularly those employing a microcontroller or microprocessor with A/D inputs. This patented, single element transducer combines advanced micromachining techniques, thin-film metallization, and bipolar processing to provide an accurate, high level analog output signal that is proportional to the applied pressure.

### Features

- 5.0% Maximum Error Over 0° to 85°C
- Ideally Suited for Microprocessor or Microcontroller-Based Systems
- Temperature Compensated Over -40° to +125°C
- Thermoplastic (PPS) Surface Mount Package
- Patented Silicon Shear Stress Strain Gauge
- Available in Differential and Gauge Configurations

## MPXV7025 Series

-25 to 25 kPa (-3.6 to 3.6 psi)  
0.2 to 4.7 V Output

### Application Examples

- Respiratory Systems
- Process Control
- Patient Monitoring
- Remote Monitoring Devices

ORDERING INFORMATION									
Device Name	Package Options	Case No.	# of Ports			Pressure Type			Device Marking
			None	Single	Dual	Gauge	Differential	Absolute	
<b>Small Outline Package (MPXV7025 Series)</b>									
MPXV7025GC6U	Rails	482A		•		•			MPXV7025G
MPXV7025GC6T1	Tape & Reel	482A		•		•			MPXV7025G
MPXV7025GP	Trays	1369		•		•			MPXV7025GP
MPXV7025DP	Trays	1351			•		•		MPXV7025DP
<b>Small Outline Package (Media Resistant Gel) (MPVZ7025 Series)</b>									
MPVZ7025GC6T1	Tape & Reel	482A		•		•			MPVZ7025G
MPVZ7025GC6U	Rails	482A		•		•			MPVZ7025G
MPVZ7025GP	Trays	1369		•		•			MPVZ7025GP
MPVZ7025G6T1	Tape & Reel	482	•				•		MPVZ7025G
MPVZ7025G6U	Rails	482	•				•		MPVZ7025G
MPVZ7025DP	Trays	1351			•		•		MPVZ7025DP

### SMALL OUTLINE PACKAGE

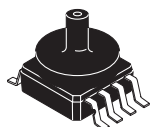

MPXV7025GC6U/T1  
MPVZ7025GC6U/T1  
CASE 482A-01

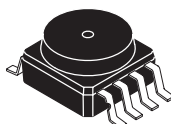

MPVZ7025G6U/T1  
CASE 482-01

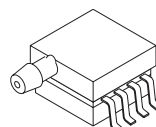

MPXV7025GP  
MPVZ7025GP  
CASE 1369-01

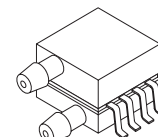

MPXV7025DP  
MPVZ7025DP  
CASE 1351-01

**Table 1. Operating Characteristics** ( $V_S = 5.0$  Vdc,  $T_A = 25^\circ\text{C}$  unless otherwise noted,  $P_1 > P_2$ . Decoupling circuit shown in Figure 3 required to meet electrical specifications.)

Characteristic	Symbol	Min	Typ	Max	Unit
Pressure Range <sup>(1)</sup>	$P_{OP}$	-25	—	25	kPa
Supply Voltage <sup>(2)</sup>	$V_S$	4.75	5.0	5.25	Vdc
Supply Current	$I_o$	—	7.0	10	mAdc
Minimum Pressure Offset <sup>(3)</sup> @ $V_S = 5.0$ Volts	$V_{off}$	0.116	0.25	0.384	Vdc
Full Scale Output <sup>(4)</sup> @ $V_S = 5.0$ Volts	$V_{FSO}$	4.610	4.75	4.890	Vdc
Full Scale Span <sup>(5)</sup> @ $V_S = 5.0$ Volts	$V_{FSS}$	—	4.5	—	Vdc
Accuracy	—	—	—	$\pm 5.0$	$\%V_{FSS}$
Sensitivity	V/P	—	90	—	mV/kPa
Response Time <sup>(6)</sup>	$t_R$	—	1.0	—	ms
Output Source Current at Full Scale Output	$I_{o+}$	—	0.1	—	mAdc
Warm-Up Time <sup>(7)</sup>	—	—	20	—	ms
Offset Stability <sup>(8)</sup>	—	—	$\pm 0.5$	—	$\%V_{FSS}$

1. 1.0 kPa (kiloPascal) equals 0.145 psi.

2. Device is ratiometric within this specified excitation range.

3. Offset ( $V_{off}$ ) is defined as the output voltage at the minimum rated pressure.

4. Full Scale Output ( $V_{FSO}$ ) is defined as the output voltage at the maximum or full rated pressure.

5. Full Scale Span ( $V_{FSS}$ ) is defined as the algebraic difference between the output voltage at full rated pressure and the output voltage at the minimum rated pressure.

6. Response Time is defined as the time for the incremental change in the output to go from 10% to 90% of its final value when subjected to a specified step change in pressure.

7. Warm-up Time is defined as the time required for the product to meet the specified output voltage after the Pressure has been stabilized.

8. Offset Stability is the product's output deviation when subjected to 1000 hours of Pulsed Pressure, Temperature Cycling with Bias Test.

## Maximum Ratings

**Table 2. Maximum Ratings<sup>(1)</sup>**

Rating	Symbol	Value	Unit
Maximum Pressure (P1 > P2)	$P_{max}$	200	kPa
Storage Temperature	$T_{stg}$	-40 to +125	°C
Operating Temperature	$T_A$	-40 to +125	°C

1. Exposure beyond the specified limits may cause permanent damage or degradation to the device.

Figure 1 shows a block diagram of the internal circuitry integrated on a pressure sensor chip.

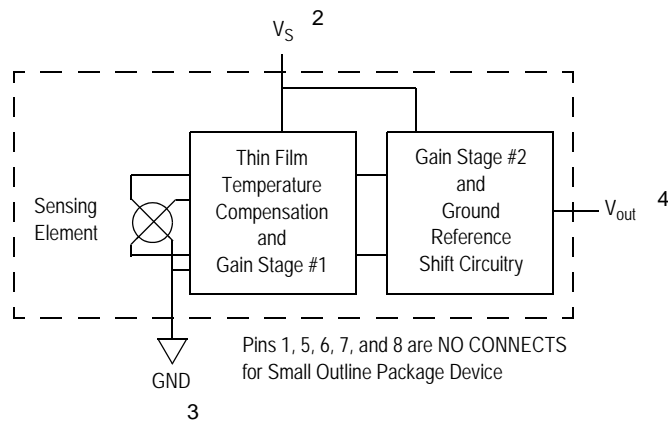

**Figure 1. Integrated Pressure Sensor Schematic**

The MPXV7025 series pressure sensor operating characteristics, and internal reliability and qualification tests are based on use of dry air as the pressure media. Media, other than dry air, may have adverse effects on sensor performance and long-term reliability. Contact the factory for information regarding media compatibility in your application.

Figure 2 shows the sensor output signal relative to pressure input. Typical, minimum, and maximum output

curves are shown for operation over a temperature range of 0° to 85°C using the decoupling circuit shown in Figure 3. The output will saturate outside of the specified pressure range.

Figure 3 shows the recommended decoupling circuit for interfacing the output of the integrated sensor to the A/D input of a microprocessor or microcontroller. Proper decoupling of the power supply is recommended.

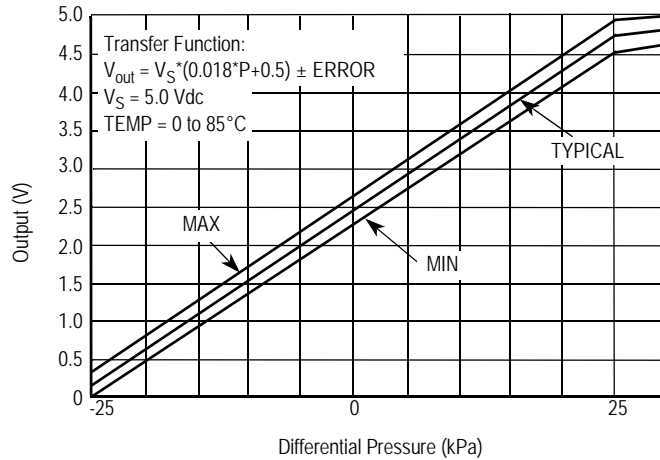

Figure 2. Output versus Pressure Differential

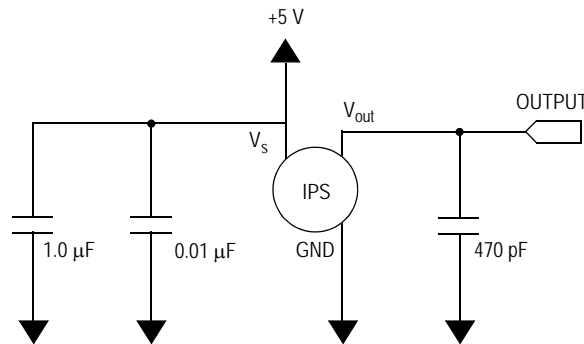

Figure 3. Recommended Power Supply Decoupling and Output Filtering  
 (For additional output filtering, please refer to Application Note AN1646.)

**Transfer Function**

**Nominal Transfer Value:**  $V_{out} = V_S (P \times 0.018 + 0.5)$   
 $\pm (\text{Pressure Error} \times \text{Temp. Factor} \times 0.018 \times V_S)$   
 $V_S = 5.0 \text{ V} \pm 0.25 \text{ Vdc}$

**Temperature Error Band**

**MPXV7025 SERIES**

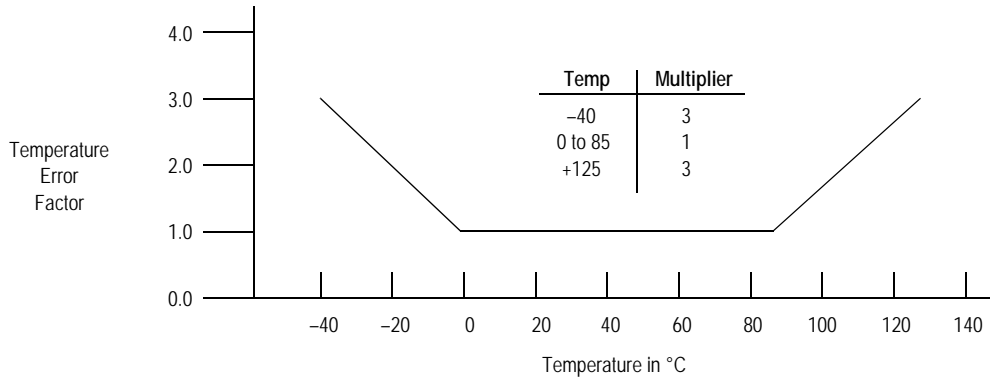

NOTE: The Temperature Multiplier is a linear response from 0° to -40°C and from 85° to 125°C.

**Pressure Error Band**

**Error Limits for Pressure**

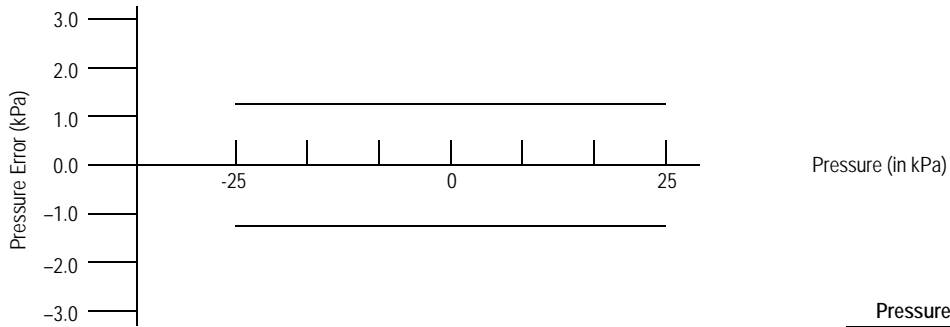

Pressure	Error (Max)
-25 to 25 (kPa)	±1.25 (kPa)

**PRESSURE (P1)/VACUUM (P2) SIDE IDENTIFICATION TABLE**

Freescale designates the two sides of the pressure sensor as the Pressure (P1) side and the Vacuum (P2) side. The Pressure (P1) side is the side containing fluorosilicone gel which protects the die from harsh media. The pressure

sensor is designed to operate with positive differential pressure applied, P1 > P2.

The Pressure (P1) side may be identified by using the following table:

Part Number	Case Type	Pressure (P1) Side Identifier
MPXV7025GC6U/C6T1, MPVZ7025GC6U/T1	482A	Side with Port Attached
MPXV7025GP, MPVZ7025GP	1369	Side with Port Attached
MPXV7025DP, MPVZ7025DP	1351	Side with Part Marking
MPVZ7025G6U/T1	482	Side with Part Marking

**MINIMUM RECOMMENDED FOOTPRINT FOR SURFACE MOUNTED APPLICATIONS**

Surface mount board layout is a critical portion of the total design. The footprint for the surface mount packages must be the correct size to ensure proper solder connection interface between the board and the package. With the correct

footprint, the packages will self align when subjected to a solder reflow process. It is always recommended to design boards with a solder mask layer to avoid bridging and shorting between solder pads.

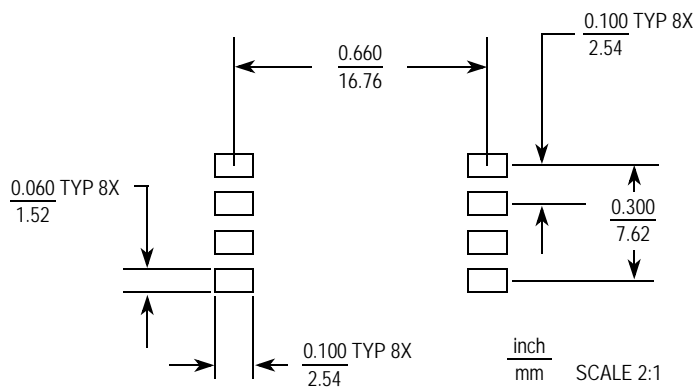
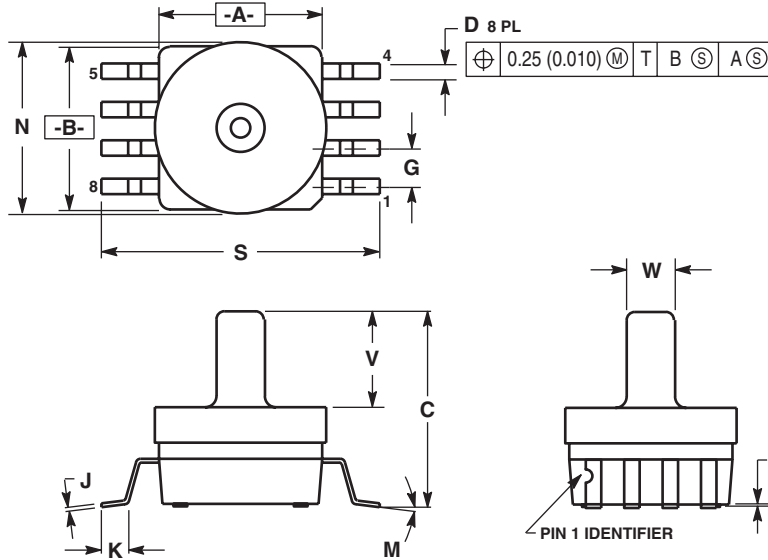

Figure 4. Small Outline Package Footprint

PACKAGE DIMENSIONS



- NOTES:
1. DIMENSIONING AND TOLERANCING PER ANSI Y14.5M, 1982.
  2. CONTROLLING DIMENSION: INCH.
  3. DIMENSION A AND B DO NOT INCLUDE MOLD PROTRUSION.
  4. MAXIMUM MOLD PROTRUSION 0.15 (0.006).
  5. ALL VERTICAL SURFACES 5° TYPICAL DRAFT.

DIM	INCHES		MILLIMETERS	
	MIN	MAX	MIN	MAX
A	0.415	0.425	10.54	10.79
B	0.415	0.425	10.54	10.79
C	0.500	0.520	12.70	13.21
D	0.038	0.042	0.96	1.07
G	0.100 BSC		2.54 BSC	
H	0.002	0.010	0.05	0.25
J	0.009	0.011	0.23	0.28
K	0.061	0.071	1.55	1.80
M	0°	7°	0°	7°
N	0.444	0.448	11.28	11.38
S	0.709	0.725	18.01	18.41
V	0.245	0.255	6.22	6.48
W	0.115	0.125	2.92	3.17

CASE 482A-01  
ISSUE A  
SMALL OUTLINE PACKAGE

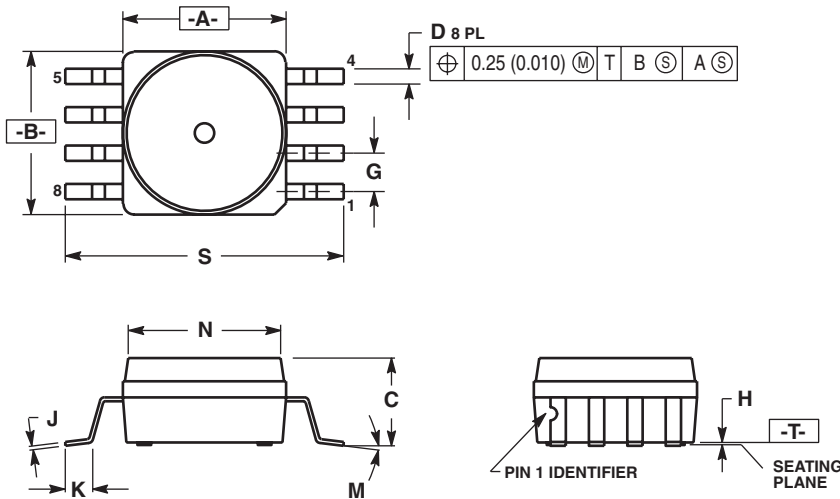

- NOTES:
1. DIMENSIONING AND TOLERANCING PER ANSI Y14.5M, 1982.
  2. CONTROLLING DIMENSION: INCH.
  3. DIMENSION A AND B DO NOT INCLUDE MOLD PROTRUSION.
  4. MAXIMUM MOLD PROTRUSION 0.15 (0.006).
  5. ALL VERTICAL SURFACES 5° TYPICAL DRAFT.

DIM	INCHES		MILLIMETERS	
	MIN	MAX	MIN	MAX
A	0.415	0.425	10.54	10.79
B	0.415	0.425	10.54	10.79
C	0.212	0.230	5.38	5.84
D	0.038	0.042	0.96	1.07
G	0.100 BSC		2.54 BSC	
H	0.002	0.010	0.05	0.25
J	0.009	0.011	0.23	0.28
K	0.061	0.071	1.55	1.80
M	0°	7°	0°	7°
N	0.405	0.415	10.29	10.54
S	0.709	0.725	18.01	18.41

CASE 482-01  
ISSUE O  
SMALL OUTLINE PACKAGE

PACKAGE DIMENSIONS

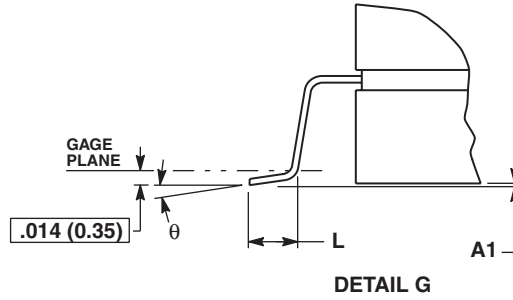
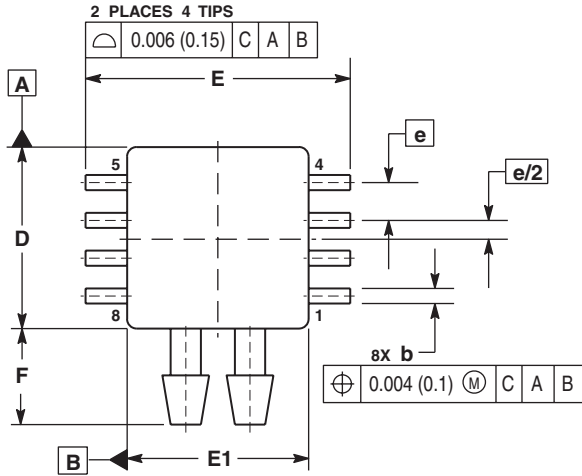

NOTES:

1. CONTROLLING DIMENSION: INCH.
2. INTERPRET DIMENSIONS AND TOLERANCES PER ASME Y14.5M, 1994.
3. DIMENSIONS "D" AND "E1" DO NOT INCLUDE MOLD FLASH OR PROTRUSIONS. MOLD FLASH OR PROTRUSIONS SHALL NOT EXCEED 0.006 (0.152) PER SIDE.
4. DIMENSION "b" DOES NOT INCLUDE DAMBAR PROTRUSION. ALLOWABLE DAMBAR PROTRUSION SHALL BE 0.008 (0.203) MAXIMUM.

- STYLE 1:  
 PIN 1. GND  
 2. +Vout  
 3. Vs  
 4. -Vout  
 5. N/C  
 6. N/C  
 7. N/C  
 8. N/C
- STYLE 2:  
 PIN 1. N/C  
 2. Vs  
 3. GND  
 4. Vout  
 5. N/C  
 6. N/C  
 7. N/C  
 8. N/C

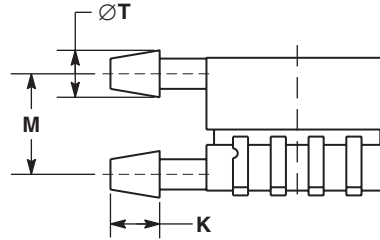
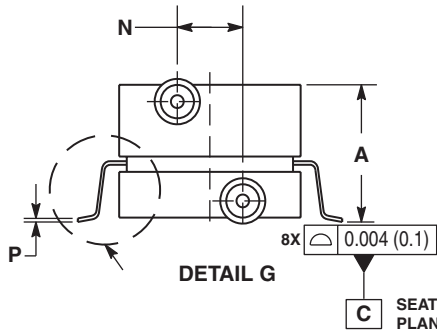

DIM	INCHES		MILLIMETERS	
	MIN	MAX	MIN	MAX
A	0.370	0.390	9.39	9.91
A1	0.002	0.010	0.05	0.25
b	0.038	0.042	0.96	1.07
D	0.465	0.485	11.81	12.32
E	0.680	0.700	17.27	17.78
E1	0.465	0.485	11.81	12.32
e	0.100 BSC		2.54 BSC	
F	0.240	0.260	6.10	6.60
K	0.115	0.135	2.92	3.43
L	0.040	0.060	1.02	1.52
M	0.270	0.290	6.86	7.37
N	0.160	0.180	4.06	4.57
P	0.009	0.011	0.23	0.28
T	0.110	0.130	2.79	3.30
$\theta$	0°	7°	0°	7°

CASE 1351-01  
 ISSUE O  
 SMALL OUTLINE PACKAGE



PACKAGE DIMENSIONS

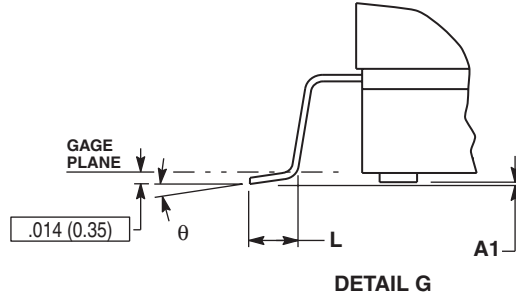
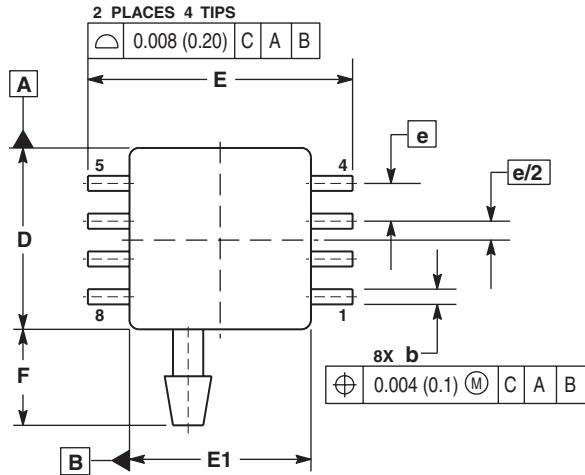

- NOTES:
1. CONTROLLING DIMENSION: INCH.
  2. INTERPRET DIMENSIONS AND TOLERANCES PER ASME Y14.5M, 1994.
  3. DIMENSIONS "D" AND "E1" DO NOT INCLUDE MOLD FLASH OR PROTRUSIONS. MOLD FLASH OR PROTRUSIONS SHALL NOT EXCEED 0.006 (0.152) PER SIDE.
  4. DIMENSION "b" DOES NOT INCLUDE DAMBAR PROTRUSION. ALLOWABLE DAMBAR PROTRUSION SHALL BE 0.008 (0.203) MAXIMUM.

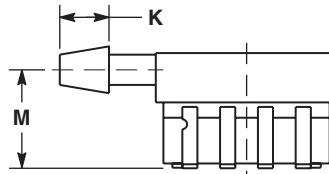
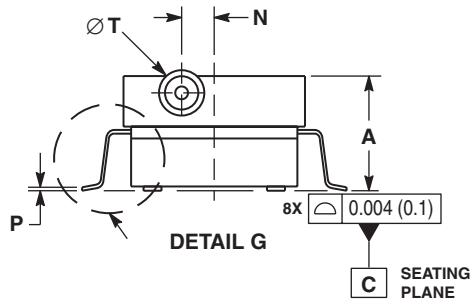

DIM	INCHES		MILLIMETERS	
	MIN	MAX	MIN	MAX
A	0.300	0.330	7.11	7.62
A1	0.002	0.010	0.05	0.25
b	0.038	0.042	0.96	1.07
D	0.465	0.485	11.81	12.32
E	0.717 BSC		18.21 BSC	
E1	0.465	0.485	11.81	12.32
e	0.100 BSC		2.54 BSC	
F	0.245	0.255	6.22	6.47
K	0.120	0.130	3.05	3.30
L	0.061	0.071	1.55	1.80
M	0.270	0.290	6.86	7.36
N	0.080	0.090	2.03	2.28
P	0.009	0.011	0.23	0.28
T	0.115	0.125	2.92	3.17
$\theta$	0°	7°	0°	7°

CASE 1369-01  
 ISSUE O  
 SMALL OUTLINE PACKAGE

## **How to Reach Us:**

### **Home Page:**

[www.freescale.com](http://www.freescale.com)

### **Web Support:**

<http://www.freescale.com/support>

### **USA/Europe or Locations Not Listed:**

Freescale Semiconductor, Inc.  
Technical Information Center, EL516  
2100 East Elliot Road  
Tempe, Arizona 85284  
1-800-521-6274 or +1-480-768-2130  
[www.freescale.com/support](http://www.freescale.com/support)

### **Europe, Middle East, and Africa:**

Freescale Halbleiter Deutschland GmbH  
Technical Information Center  
Schatzbogen 7  
81829 Muenchen, Germany  
+44 1296 380 456 (English)  
+46 8 52200080 (English)  
+49 89 92103 559 (German)  
+33 1 69 35 48 48 (French)  
[www.freescale.com/support](http://www.freescale.com/support)

### **Japan:**

Freescale Semiconductor Japan Ltd.  
Headquarters  
ARCO Tower 15F  
1-8-1, Shimo-Meguro, Meguro-ku,  
Tokyo 153-0064  
Japan  
0120 191014 or +81 3 5437 9125  
[support.japan@freescale.com](mailto:support.japan@freescale.com)

### **Asia/Pacific:**

Freescale Semiconductor China Ltd.  
Exchange Building 23F  
No. 118 Jianguo Road  
Chaoyang District  
Beijing 100022  
China  
+86 010 5879 8000  
[support.asia@freescale.com](mailto:support.asia@freescale.com)

### **For Literature Requests Only:**

Freescale Semiconductor Literature Distribution Center  
P.O. Box 5405  
Denver, Colorado 80217  
1-800-441-2447 or +1-303-675-2140  
Fax: +1-303-675-2150  
[LDCForFreescaleSemiconductor@hibbertgroup.com](mailto:LDCForFreescaleSemiconductor@hibbertgroup.com)

Information in this document is provided solely to enable system and software implementers to use Freescale Semiconductor products. There are no express or implied copyright licenses granted hereunder to design or fabricate any integrated circuits or integrated circuits based on the information in this document.

Freescale Semiconductor reserves the right to make changes without further notice to any products herein. Freescale Semiconductor makes no warranty, representation or guarantee regarding the suitability of its products for any particular purpose, nor does Freescale Semiconductor assume any liability arising out of the application or use of any product or circuit, and specifically disclaims any and all liability, including without limitation consequential or incidental damages. "Typical" parameters that may be provided in Freescale Semiconductor data sheets and/or specifications can and do vary in different applications and actual performance may vary over time. All operating parameters, including "Typicals", must be validated for each customer application by customer's technical experts. Freescale Semiconductor does not convey any license under its patent rights nor the rights of others. Freescale Semiconductor products are not designed, intended, or authorized for use as components in systems intended for surgical implant into the body, or other applications intended to support or sustain life, or for any other application in which the failure of the Freescale Semiconductor product could create a situation where personal injury or death may occur. Should Buyer purchase or use Freescale Semiconductor products for any such unintended or unauthorized application, Buyer shall indemnify and hold Freescale Semiconductor and its officers, employees, subsidiaries, affiliates, and distributors harmless against all claims, costs, damages, and expenses, and reasonable attorney fees arising out of, directly or indirectly, any claim of personal injury or death associated with such unintended or unauthorized use, even if such claim alleges that Freescale Semiconductor was negligent regarding the design or manufacture of the part.

Freescale™ and the Freescale logo are trademarks of Freescale Semiconductor, Inc. All other product or service names are the property of their respective owners.

© Freescale Semiconductor, Inc. 2009. All rights reserved.