

TLE42664

Low Dropout Fixed Voltage Regulator

Automotive Power



Never stop thinking



1 Overview

Features

- Output Voltage 5 V \pm 2 % up to Output Currents of 50 mA
- Output Voltage 5 V \pm 3 % up to Output Currents 100 mA
- Very Low Dropout Voltage
- Very Low Current Consumption: typ. 40 μ A
- Enable Input
- Output Current Limitation
- Reverse Polarity Protection
- Overtemperature Shutdown
- Wide Temperature Range From -40 °C up to 150 °C
- Suitable for Use in Automotive Electronics
- Green Product (RoHS compliant)
- AEC Qualified

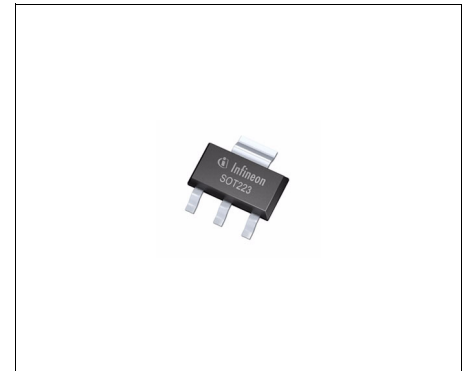

PG-SOT223-4

Description

The TLE42664 is a monolithic integrated low dropout fixed voltage regulator for load currents up to 100 mA. It is the 1-to-1 replacement product for the TLE4266-2. It is functional compatible to the TLE4266, but has a reduced quiescent current of typ. 40 μ A. The TLE42664 is especially designed for applications requiring very low standby currents, e.g. with a permanent connection to the car's battery. It can be disabled/enabled by the integrated EN pin. The device is available in the small surface mounted PG-SOT223-4 package and is pin compatible to the TLE4266-2 and the TLE4266. The device is designed for the harsh environment of automotive applications. Therefore it is protected against overload, short circuit and overtemperature conditions by the implemented output current limitation and the overtemperature shutdown circuit. The TLE42664 can be also used in all other applications requiring a stabilized 5 V voltage.

An input voltage up to 45 V is regulated to $V_{Q,nom} = 5$ V with a precision of \pm 3 %. An accuracy of \pm 2 % is kept for load currents up to 50 mA. A logical "HIGH" at the ENABLE pin enables the device.

Type	Package	Marking
TLE42664G	PG-SOT223-4	42664

2 Block Diagram

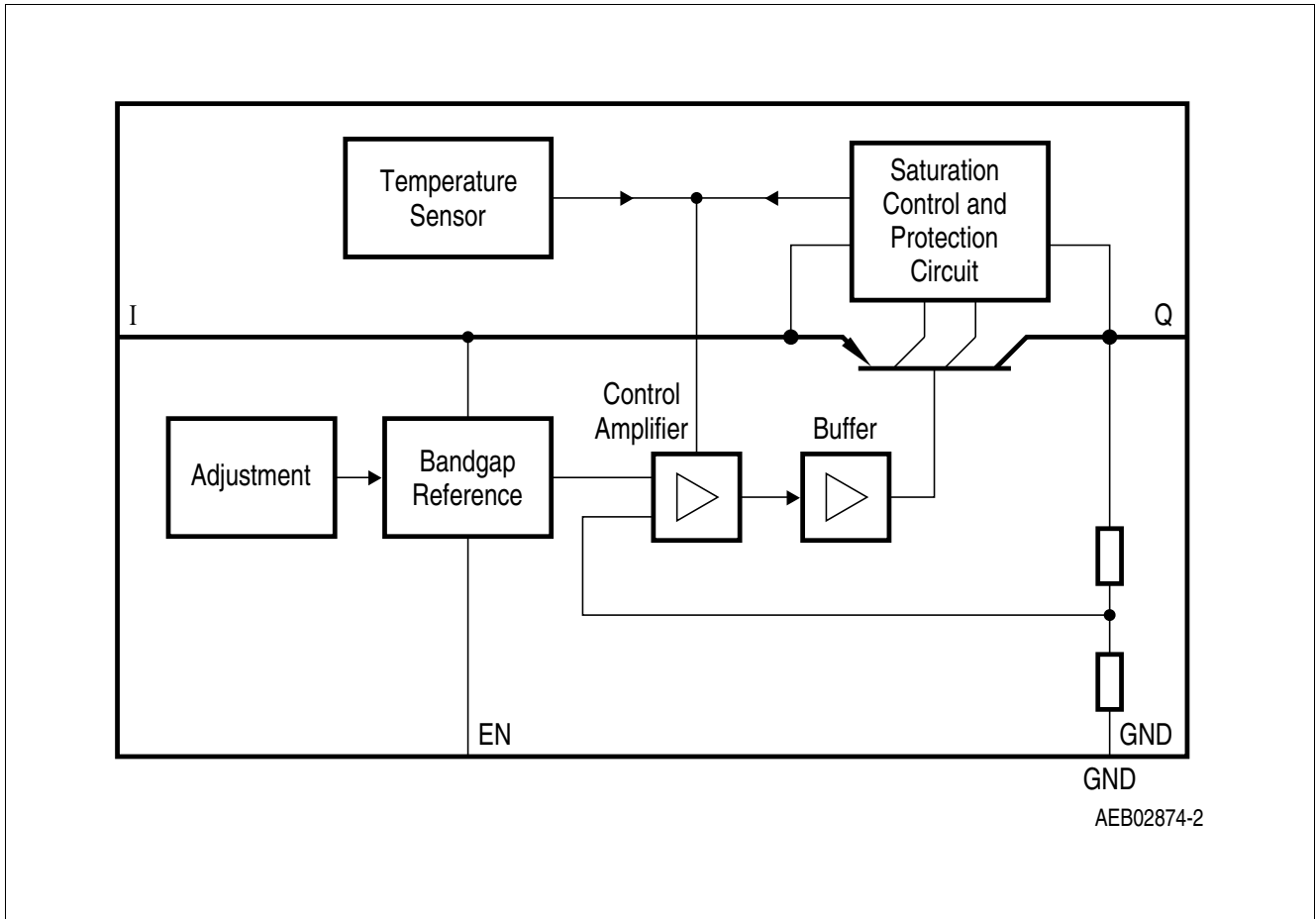

Figure 1 Block Diagram

3 Pin Configuration

3.1 Pin Assignment PG-SOT223-4

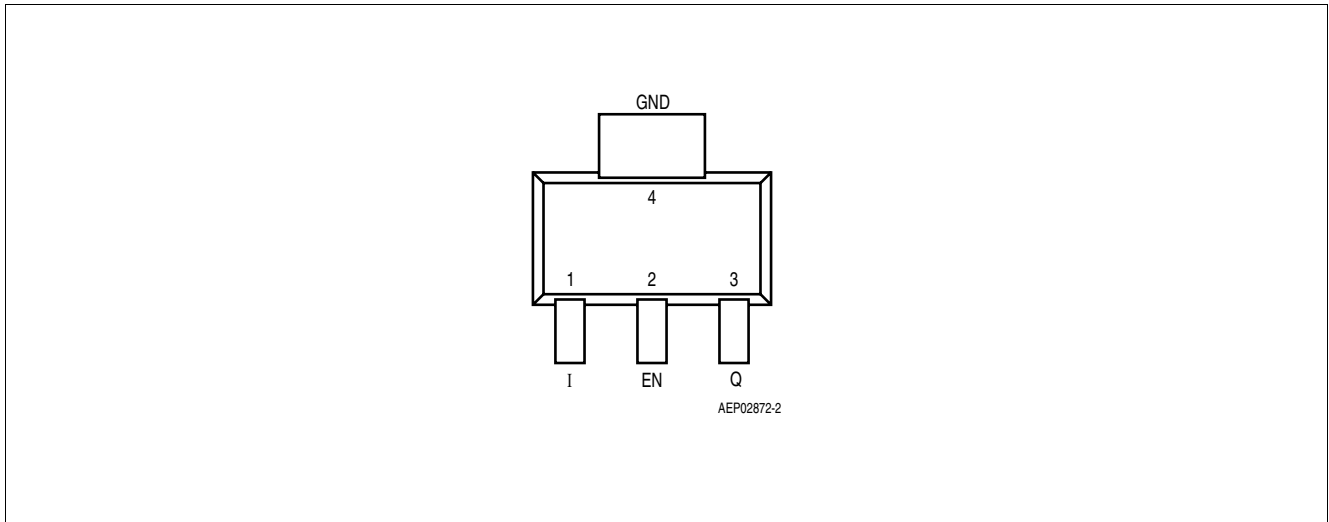

Figure 2 Pin Configuration (top view)

3.2 Pin Definitions and Functions PG-SOT223-4

Pin No.	Symbol	Function
1	I	Input block to ground directly at the IC with a ceramic capacitor
2	EN	Enable Input high level enables the device; low level disables the device; integrated pull-down resistor
3	Q	Output block to ground with a capacitor close to the IC terminals, respecting the values given for its capacitance and ESR in “Functional Range” on Page 5
4 / Heat Slug	GND	Ground / Heat Slug internally connected to leadframe and GND; connect to GND and heatsink area

4 General Product Characteristics

4.1 Absolute Maximum Ratings

Absolute Maximum Ratings¹⁾

$T_j = -40\text{ °C}$ to 150 °C ; all voltages with respect to ground, (unless otherwise specified)

Pos.	Parameter	Symbol	Limit Values		Unit	Test Condition
			Min.	Max.		
Input I, Enable EN						
4.1.1	Voltage	V_I, V_{EN}	-30	45	V	–
Output Q						
4.1.2	Voltage	V_Q	-0.3	32	V	–
Temperature						
4.1.3	Junction temperature	T_j	-40	150	°C	–
4.1.4	Storage temperature	T_{stg}	-50	150	°C	–
ESD Susceptibility						
4.1.5	ESD Absorption	$V_{ESD,HBM}$	-3	3	kV	Human Body Model (HBM) ²⁾
4.1.6		$V_{ESD,CDM}$	-1500	1500	V	Charge Device Model (CDM) ³⁾ at all pins

1) not subject to production test, specified by design

2) ESD susceptibility Human Body Model "HBM" according to AEC-Q100-002 - JESD22-A114

3) ESD susceptibility Charged Device Model "CDM" according to ESDA STM5.3.1

Note: Stresses above the ones listed here may cause permanent damage to the device. Exposure to absolute maximum rating conditions for extended periods may affect device reliability.

Note: Integrated protection functions are designed to prevent IC destruction under fault conditions described in the data sheet. Fault conditions are considered as "outside" normal operating range. Protection functions are not designed for continuous repetitive operation.

4.2 Functional Range

Pos.	Parameter	Symbol	Limit Values		Unit	Remarks
			Min.	Max.		
4.2.1	Input voltage	V_I	5.5	40	V	
4.2.2	Output Capacitor's	C_Q	10	–	µF	–
4.2.3	Requirements for Stability	$ESR(C_Q)$	–	2	Ω	¹⁾
4.2.4	Junction temperature	T_j	-40	150	°C	–

1) relevant ESR value at $f = 10\text{ kHz}$

Note: Within the functional or operating range, the IC operates as described in the circuit description. The electrical characteristics are specified within the conditions given in the Electrical Characteristics table.

4.3 Thermal Resistance

Note: This thermal data was generated in accordance with JEDEC JESD51 standards. For more information, go to www.jedec.org.

Pos.	Parameter	Symbol	Limit Values			Unit	Conditions
			Min.	Typ.	Max.		
TLE42664G (PG-SOT223-4)							
4.3.1	Junction to Case ¹⁾	R_{thJC}	–	17	–	K/W	measured to heat slug
4.3.2	Junction to Ambient ¹⁾	R_{thJA}	–	54	–	K/W	²⁾
4.3.3			–	139	–	K/W	footprint only ³⁾
4.3.4			–	73	–	K/W	300 mm ² heatsink area ³⁾
4.3.5			–	64	–	K/W	600 mm ² heatsink area ³⁾

- 1) Not subject to production test, specified by design.
- 2) Specified R_{thJA} value is according to Jedec JESD51-2,-5,-7 at natural convection on FR4 2s2p board; The Product (Chip+Package) was simulated on a 76.2 x 114.3 x 1.5 mm³ board with 2 inner copper layers (2 x 70µm Cu, 2 x 35µm Cu). Where applicable a thermal via array under the exposed pad contacted the first inner copper layer.
- 3) Specified R_{thJA} value is according to Jedec JESD 51-3 at natural convection on FR4 1s0p board; The Product (Chip+Package) was simulated on a 76.2 x 114.3 x 1.5 mm³ board with 1 copper layer (1 x 70µm Cu).

5 Electrical Characteristics

5.1 Electrical Characteristics Voltage Regulator

Electrical Characteristics

 $V_I = 13.5 \text{ V}$; $T_j = -40 \text{ }^\circ\text{C}$ to $150 \text{ }^\circ\text{C}$; all voltages with respect to ground (unless otherwise specified)

Pos.	Parameter	Symbol	Limit Values			Unit	Measuring Condition
			Min.	Typ.	Max.		
Output Q							
5.1.1	Output Voltage	V_Q	4.9	5.0	5.1	V	$5 \text{ mA} < I_Q < 50 \text{ mA}$ $6 \text{ V} < V_I < 16 \text{ V}$
5.1.2			4.85	5.0	5.15	V	$5 \text{ mA} < I_Q < 100 \text{ mA}$ $6 \text{ V} < V_I < 21 \text{ V}$
5.1.3	Output Voltage At Low Output Currents	V_Q	4.80	5.0	5.20	V	$100 \text{ } \mu\text{A} < I_Q < 5 \text{ mA}$ $6 \text{ V} < V_I < 21 \text{ V}$
5.1.4	Dropout Voltage	V_{dr}	–	250	500	mV	$I_Q = 100 \text{ mA}$ $V_{dr} = V_I - V_Q$ ¹⁾
5.1.5	Load Regulation	$\Delta V_{Q, lo}$	–	50	90	mV	$I_Q = 1 \text{ mA}$ to 100 mA $V_I = 13.5 \text{ V}$
5.1.6	Line Regulation	$\Delta V_{Q, li}$	–	5	30	mV	$V_I = 6 \text{ V}$ to 28 V $I_Q = 1 \text{ mA}$
5.1.7	Output Current Limitation	I_Q	150	200	500	mA	¹⁾
5.1.8	Power Supply Ripple Rejection ²⁾	$PSRR$	–	68	–	dB	$f_r = 100 \text{ Hz}$; $V_r = 0.5 \text{ Vpp}$
5.1.9	Overtemperature Shutdown Threshold ²⁾	$T_{j, sd}$	151	–	200	$^\circ\text{C}$	T_j increasing
5.1.10	Overtemperature Shutdown Threshold Hysteresis ²⁾	$T_{j, sdh}$	–	25	–	$^\circ\text{C}$	T_j decreasing
Current Consumption							
5.1.11	Current Consumption Device Disabled	$I_{q, OFF}$	–	0	1	μA	$V_{EN} = 0 \text{ V}$; $T_j < 100 \text{ }^\circ\text{C}$
5.1.12	Quiescent Current $I_q = I_I - I_Q$	I_q	–	40	60	μA	$I_Q = 100 \text{ } \mu\text{A}$, $T_j < 85 \text{ }^\circ\text{C}$
5.1.13			–	40	70	μA	$I_Q = 100 \text{ } \mu\text{A}$
5.1.14	Current Consumption $I_q = I_I - I_Q$	I_q	–	1.7	4	mA	$I_Q = 50 \text{ mA}$
Enable Input							
5.1.15	High Level Input Voltage	$V_{EN, ON}$	3.5	–	–	V	–
5.1.16	Low Level Input Voltage	$V_{EN, OFF}$	–	–	0.8	V	–
5.1.17	Enable Input Current	$I_{EN, ON}$	–	4	8	μA	$V_{EN} = 5 \text{ V}$
5.1.18	Pull-down Resistor	R_{EN}	–	1.0	–	M Ω	–

1) Measured when the output voltage V_Q has dropped 100 mV from the nominal value obtained at $V_I = 13.5 \text{ V}$.

2) not subject to production test, specified by design

5.2 Typical Performance Characteristics Voltage Regulator

Current Consumption I_q versus Output Current I_Q

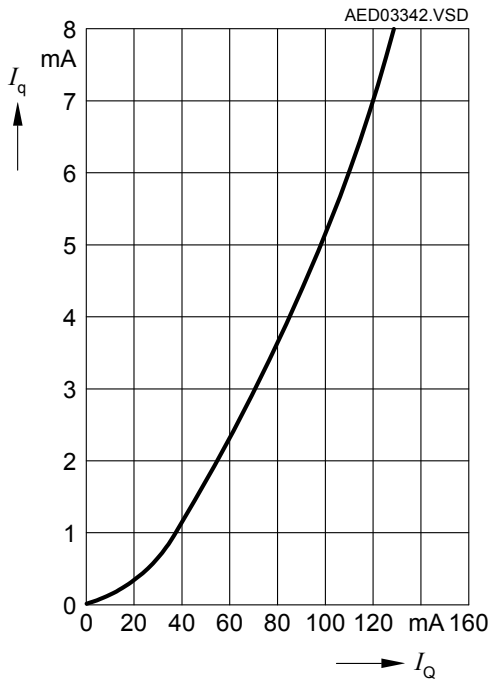

Current Consumption I_q versus Low Output Current I_Q

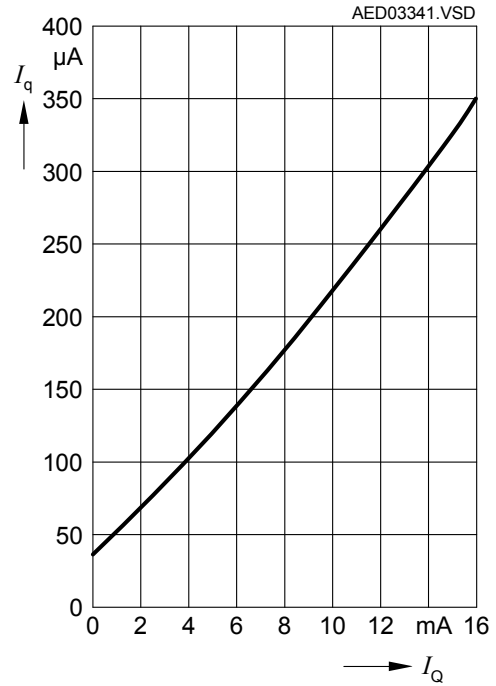

Output Voltage Variation ΔV_Q versus Junction Temperature T_j

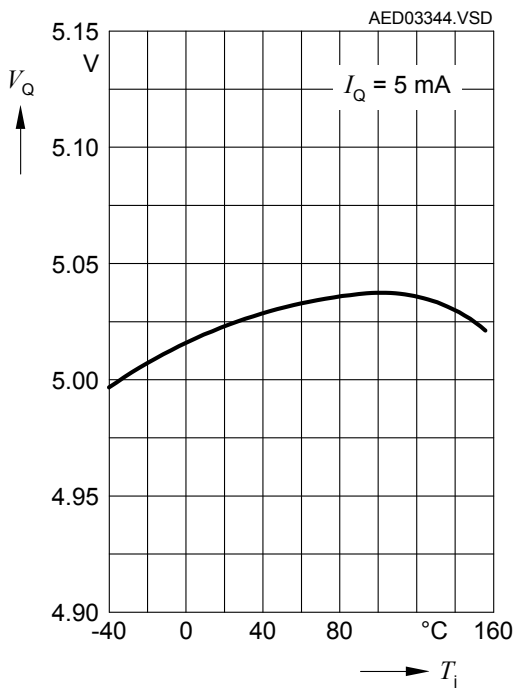

Dropout Voltage V_{dr} versus Output Current I_Q

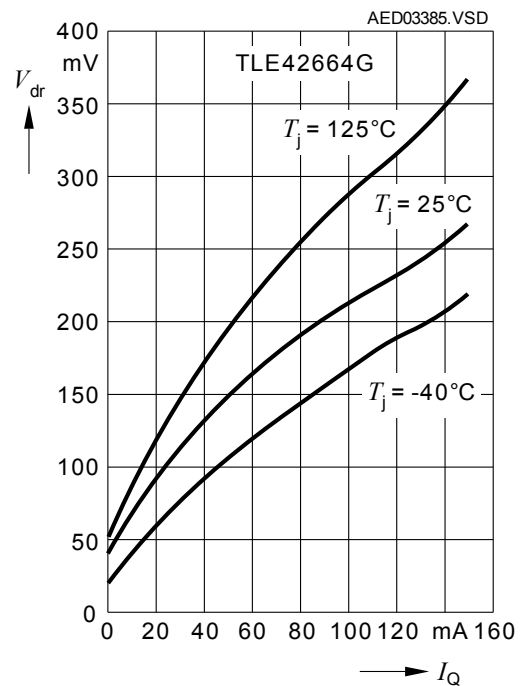

Output Voltage V_Q versus Input Voltage V_I

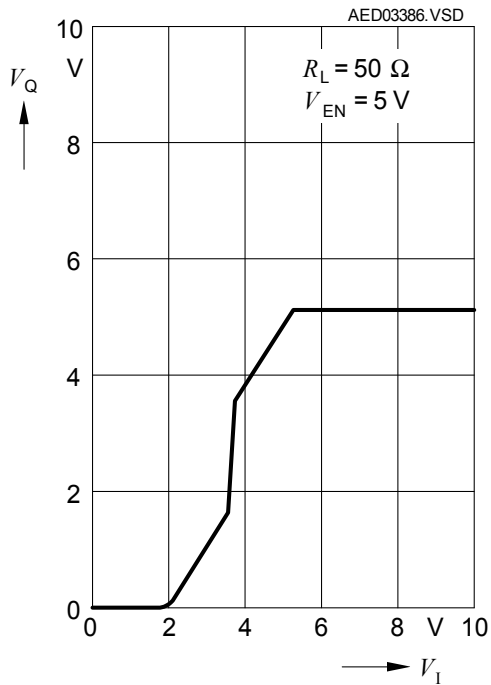

Maximum Output Current $I_{Q,max}$ versus Input Voltage V_I

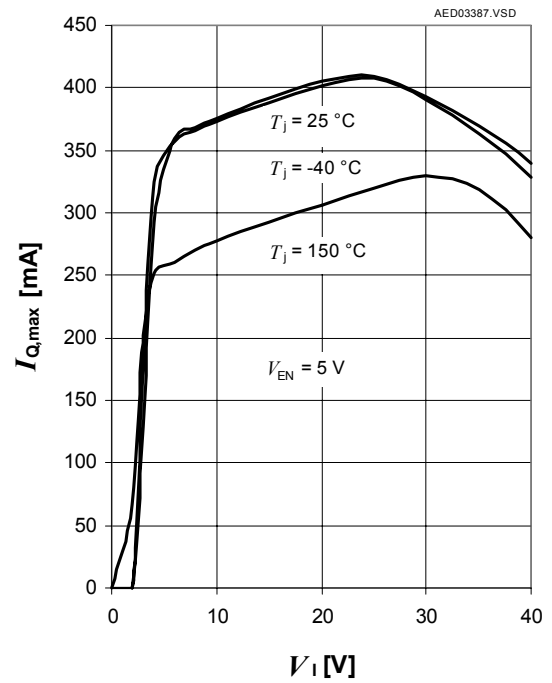

Region Of Stability: Output Capacitor's ESR $ESR(C_Q)$ versus Output Current I_Q

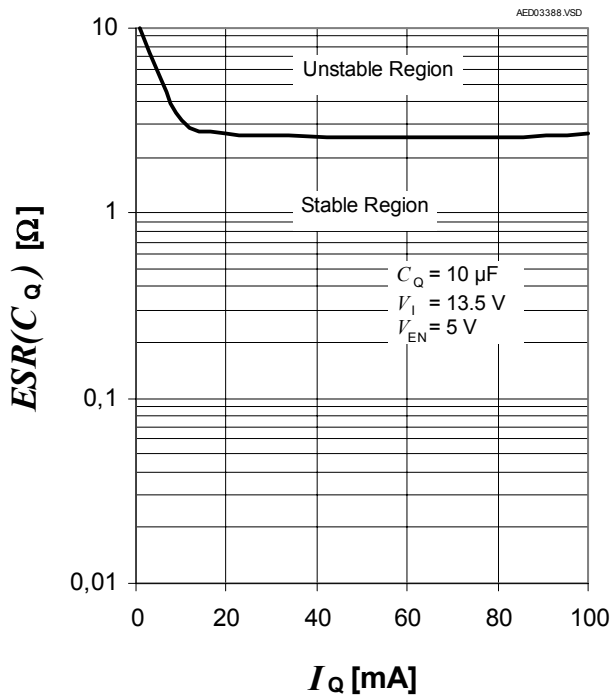

Enable Input Current I_{EN} versus Enable Input Voltage V_{EN}

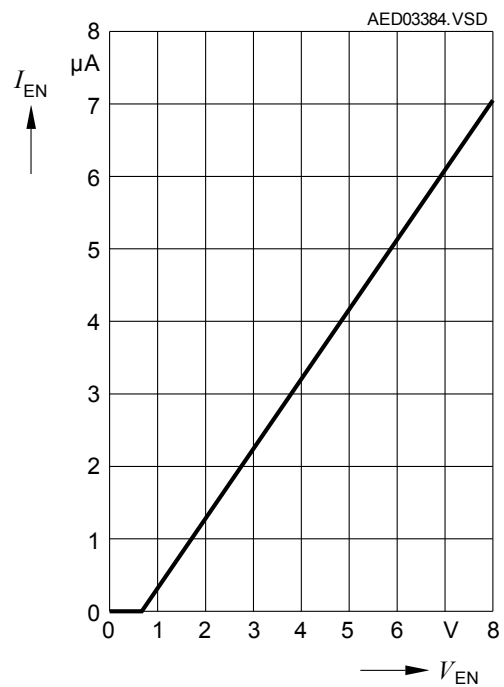

6 Package Outlines

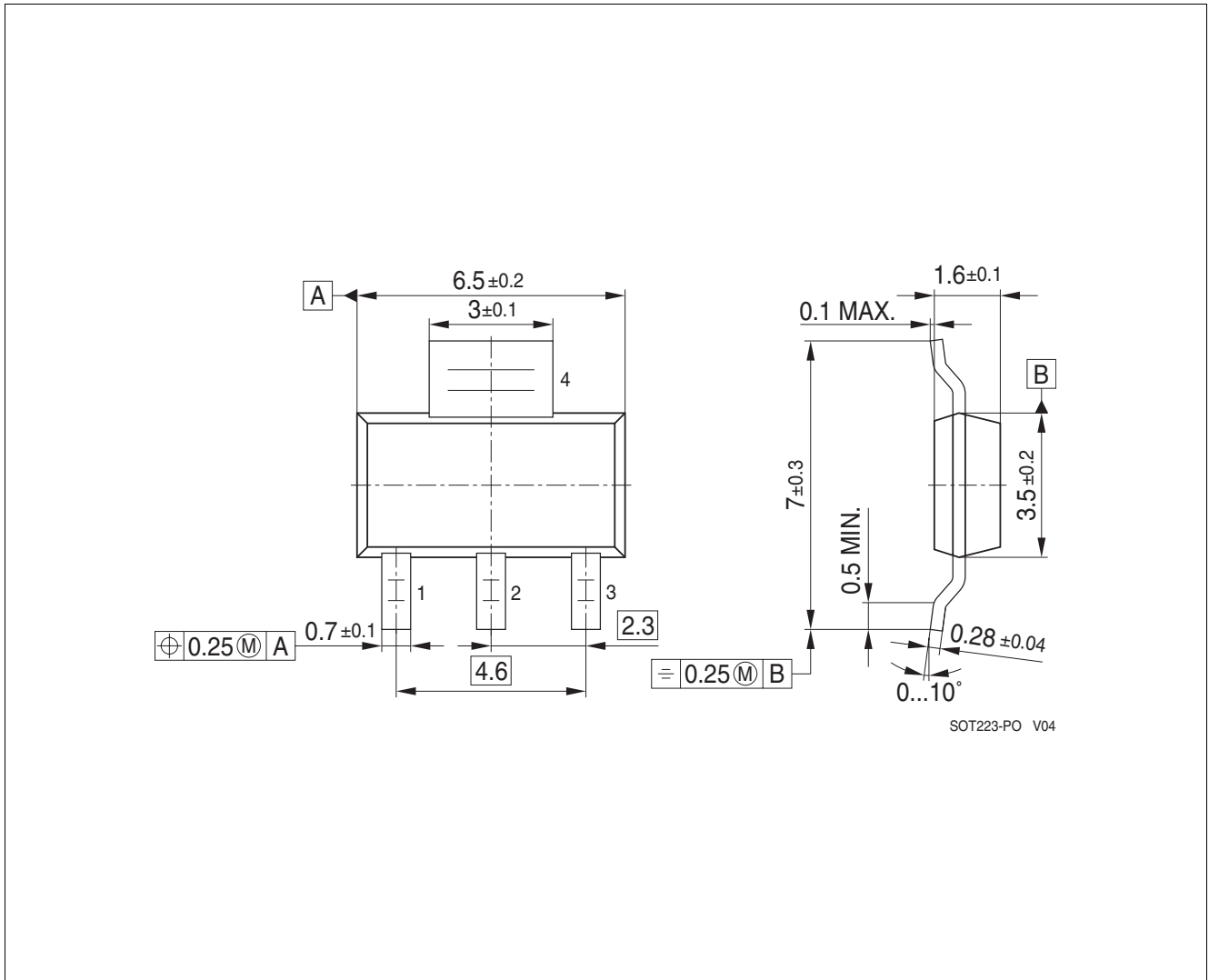

Figure 3 PG-SOT223-4

Green Product (RoHS compliant)

To meet the world-wide customer requirements for environmentally friendly products and to be compliant with government regulations the device is available as a green product. Green products are RoHS-Compliant (i.e Pb-free finish on leads and suitable for Pb-free soldering according to IPC/JEDEC J-STD-020).

For further information on alternative packages, please visit our website:
<http://www.infineon.com/packages>.

Dimensions in mm

7 Revision History

Revision	Date	Changes
1.0	2009-06-26	initial version data sheet
1.01	2009-09-30	updated version data sheet; typing error corrected in Table 4.1 “Absolute Maximum Ratings” on Page 5 : In Item 4.1.1 min. value corrected from “-42V” to “-30V”

Edition 2009-09-30

**Published by
Infineon Technologies AG
81726 Munich, Germany**

**© 2009 Infineon Technologies AG
All Rights Reserved.**

Legal Disclaimer

The information given in this document shall in no event be regarded as a guarantee of conditions or characteristics. With respect to any examples or hints given herein, any typical values stated herein and/or any information regarding the application of the device, Infineon Technologies hereby disclaims any and all warranties and liabilities of any kind, including without limitation, warranties of non-infringement of intellectual property rights of any third party.

Information

For further information on technology, delivery terms and conditions and prices, please contact the nearest Infineon Technologies Office (www.infineon.com).

Warnings

Due to technical requirements, components may contain dangerous substances. For information on the types in question, please contact the nearest Infineon Technologies Office.

Infineon Technologies components may be used in life-support devices or systems only with the express written approval of Infineon Technologies, if a failure of such components can reasonably be expected to cause the failure of that life-support device or system or to affect the safety or effectiveness of that device or system. Life support devices or systems are intended to be implanted in the human body or to support and/or maintain and sustain and/or protect human life. If they fail, it is reasonable to assume that the health of the user or other persons may be endangered.