

## TFT LCD Approval Specification

# MODEL NO.: N133I6 – L02

Customer:

Approved by:

Note:

- CONTENTS -

REVISION HISTORY	-----	3
1. GENERAL DESCRIPTION	-----	4
1.1 OVERVIEW		
1.2 FEATURES		
1.3 APPLICATION		
1.4 GENERAL SPECIFICATIONS		
1.5 MECHANICAL SPECIFICATIONS		
2. ABSOLUTE MAXIMUM RATINGS	-----	5
2.1 ABSOLUTE RATINGS OF ENVIRONMENT		
2.2 ELECTRICAL ABSOLUTE RATINGS		
2.2.1 TFT LCD MODULE		
2.2.2 BACKLIGHT UNIT		
3. ELECTRICAL CHARACTERISTICS	-----	7
3.1 TFT LCD MODULE		
3.2 BACKLIGHT UNIT		
4. BLOCK DIAGRAM	-----	11
4.1 TFT LCD MODULE		
4.2 BACKLIGHT UNIT		
5. INPUT TERMINAL PIN ASSIGNMENT	-----	12
5.1 TFT LCD MODULE		
5.2 BACKLIGHT UNIT		
5.3 TIMING DIAGRAM OF LVDS INPUT SIGNAL		
5.4 COLOR DATA INPUT ASSIGNMENT		
6. INTERFACE TIMING	-----	16
6.1 INPUT SIGNAL TIMING SPECIFICATIONS		
6.2 POWER ON/OFF SEQUENCE		
7. OPTICAL CHARACTERISTICS	-----	18
7.1 TEST CONDITIONS		
7.2 OPTICAL SPECIFICATIONS		
8. PRECAUTIONS	-----	22
8.1 HANDLING PRECAUTIONS		
8.2 STORAGE PRECAUTIONS		
8.3 OPERATION PRECAUTIONS		
9. PACKING	-----	23
9.1 CARTON		
9.2 PALLET		
10. DEFINITION OF LABELS	-----	25
10.1 CMO MODULE LABEL		
10.2 CMO CARTON LABE		
10.3 CUSTOMER CARTON LABEL		
10.4 CUSTOMER PALLET LABEL		

**REVISION HISTORY**

<b>Version</b>	<b>Date</b>	<b>Page (New)</b>	<b>Section</b>	<b>Description</b>
0.0	Mar, 26,'08	All	All	Tentative specification was first issued.
1.0	Jun, 18,'08	All	All	Preliminary specification was first issued
3.0	Sep.19.'08	All	All	Approval specification was first issued

## 1. GENERAL DESCRIPTION

### 1.1 OVERVIEW

N13316 – L02 is a 13.3” TFT Liquid Crystal Display module with LED Backlight unit and 30 pins LVDS interface. This module supports 1280 x 800 WXGA mode and can display 262,144 colors. The optimum viewing angle is at 6 o'clock direction. The converter module for Backlight is not built in.

### 1.2 FEATURES

- Thin and Light Weight
- WXGA (1280 x 800 pixels) resolution
- DE only mode
- 3.3V LVDS (Low Voltage Differential Signaling) interface with 1 pixel/clock

### 1.3 APPLICATION

- TFT LCD Notebook

### 1.4 GENERAL SPECIFICATIONS

Item	Specification	Unit	Note
Active Area	286.08 (H) x 178.8 (V)	mm	(1)
CF Polarizer	289.38 (H) x 182.3 (V)	mm	
Driver Element	a-si TFT active matrix	-	-
Pixel Number	1280 x R.G.B. x 800	pixel	-
Pixel Pitch	0.2235 (H) x 0.2235 (V)	mm	-
Pixel Arrangement	RGB vertical stripe	-	-
Display Colors	262,144	color	-
Transmissive Mode	Normally white	-	-
Surface Treatment	Glare, LT4 , 3H	-	-

### 1.5 MECHANICAL SPECIFICATIONS

Item	Min.	Typ.	Max.	Unit	Note	
Module Size	Horizontal(H)	296.85	297.15	297.45	mm	(1)
	Vertical(V)	202.8	203.2	203.6	mm	
	Depth(D)	3.0	3.3	3.6	mm	
Weight	--	--	310	g	-	
I/F connector mounting position	The mounting inclination of the connector makes the screen center within $\pm 0.5\text{mm}$ as the horizontal.				(2)	

Note (1) Please refer to the attached drawings for more information of front and back outline dimensions.

Note (2) Connector mounting position

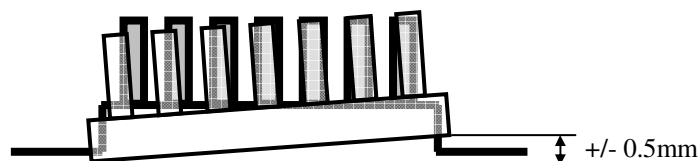

## 2. ABSOLUTE MAXIMUM RATINGS

### 2.1 ABSOLUTE RATINGS OF ENVIRONMENT

Item	Symbol	Value		Unit	Note
		Min.	Max.		
Storage Temperature	T <sub>ST</sub>	-20	+60	°C	(1)
Operating Ambient Temperature	T <sub>OP</sub>	0	+50	°C	(1), (2)
Shock (Non-Operating)	S <sub>NOP</sub>	-	200/2	G	(3), (5)
Vibration (Non-Operating)	V <sub>NOP</sub>	-	1.5	G	(4), (5)

Note (1) Temperature and relative humidity range is shown in the figure below.

- (a) 90 %RH Max. ( $T_a \leq 40$  °C).
- (b) Wet-bulb temperature should be 39 °C Max. ( $T_a > 40$  °C).
- (c) No condensation.

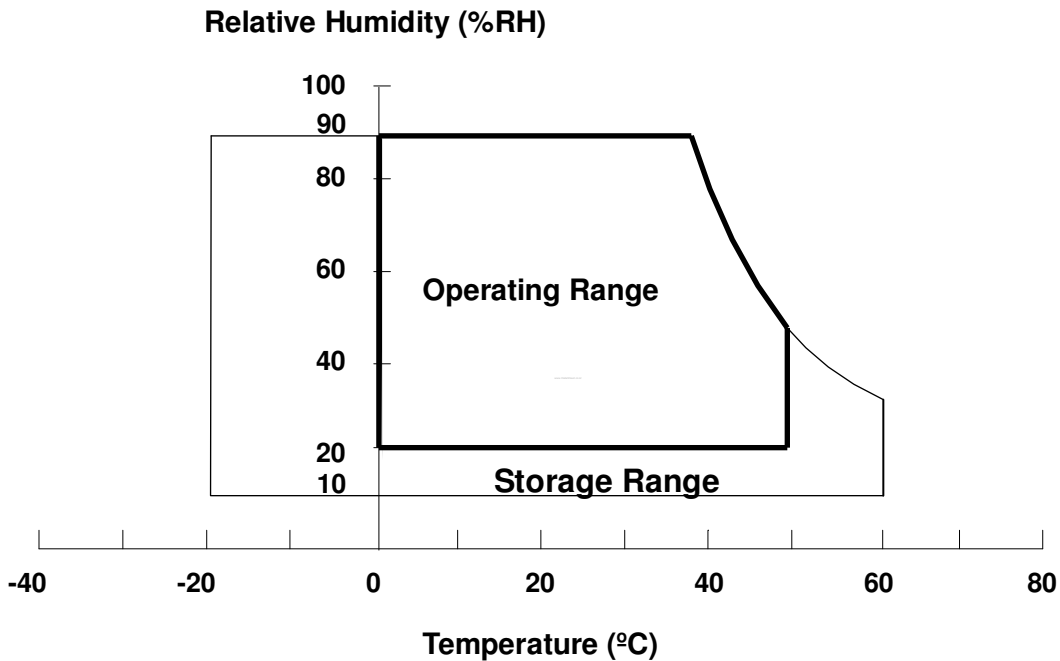

Note (2) The temperature of panel surface should be 0 °C Min. and 50 °C Max.

Note (3) 1 time for  $\pm X, \pm Y, \pm Z$ . for Condition (200G / 2ms) is half Sine Wave,.

Note (4) 10 ~ 500 Hz, 0.5 Hr / Cycle, 1 cycles for each X, Y, Z.

Note (5) At testing Vibration and Shock, the fixture in holding the module has to be hard and rigid enough so that the module would not be twisted or bent by the fixture.

The fixing condition is shown as below:

#### At Room Temperature

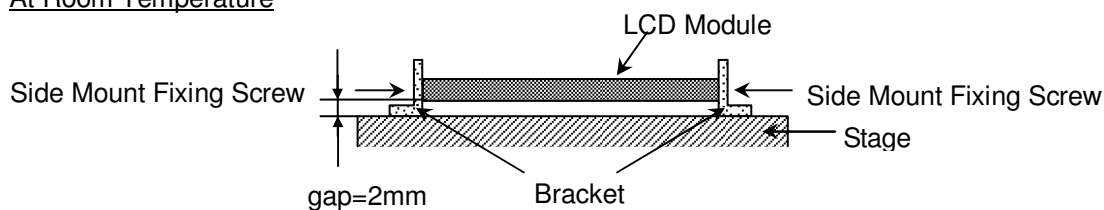

## 2.2 ELECTRICAL ABSOLUTE RATINGS

### 2.2.1 TFT LCD MODULE

Item	Symbol	Value		Unit	Note
		Min.	Max.		
Power Supply Voltage	$V_{CC}$	-0.3	+4.0	V	(1)
Logic Input Voltage	$V_{IN}$	-0.3	$V_{CC}+0.3$	V	

### 2.2.2 BACKLIGHT UNIT

Item	Value		Unit	Note
	Min	Max.		
LED Light Bar Power Supply Voltage	0	34	V	(1)
LED Light Bar Power Supply Current	0	150	mA	

Note (1) Permanent damage to the device may occur if maximum or minimum values are exceeded.

Function operation should be restricted to the conditions described under Normal Operating Conditions.

### 3. ELECTRICAL CHARACTERISTICS

#### 3.1 TFT LCD MODULE

Parameter	Symbol	Value			Unit	Note	
		Min.	Typ.	Max.			
Power Supply Voltage	V <sub>CC</sub>	3.0	3.3	3.6	V	-	
Permissible Ripple Voltage	V <sub>RP</sub>	-	50	-	mV	-	
Rush Current	I <sub>RUSH</sub>	-	-	1.5	A	(2)	
Initial Stage Current	I <sub>IS</sub>	-	-	1.0	A	(2)	
Power Supply Current	White	I <sub>CC</sub>	-	190	220	mA	(3)a
	Black		-	250	280	mA	(3)b
LVDS Differential Input High Threshold	V <sub>TH(LVDS)</sub>	-	-	+100	mV	(5), V <sub>CM</sub> =1.2V	
LVDS Differential Input Low Threshold	V <sub>TL(LVDS)</sub>	-100	-	-	mV	(5) V <sub>CM</sub> =1.2V	
LVDS Common Mode Voltage	V <sub>CM</sub>	1.125	-	1.375	V	(5)	
LVDS Differential Input Voltage	V <sub>ID</sub>	100	-	600	mV	(5)	
Terminating Resistor	R <sub>T</sub>	-	100	-	Ohm		
Power per EBL WG	P <sub>EBL</sub>	-	1.40	-	W	(4)	

Note (1) The ambient temperature is Ta = 25 ± 2 °C.

Note (2) I<sub>RUSH</sub>: the maximum current when VCC is rising

I<sub>IS</sub>: the maximum current of the first 100ms after power-on

Measurement Conditions: Shown as the following figure. Test pattern: black.

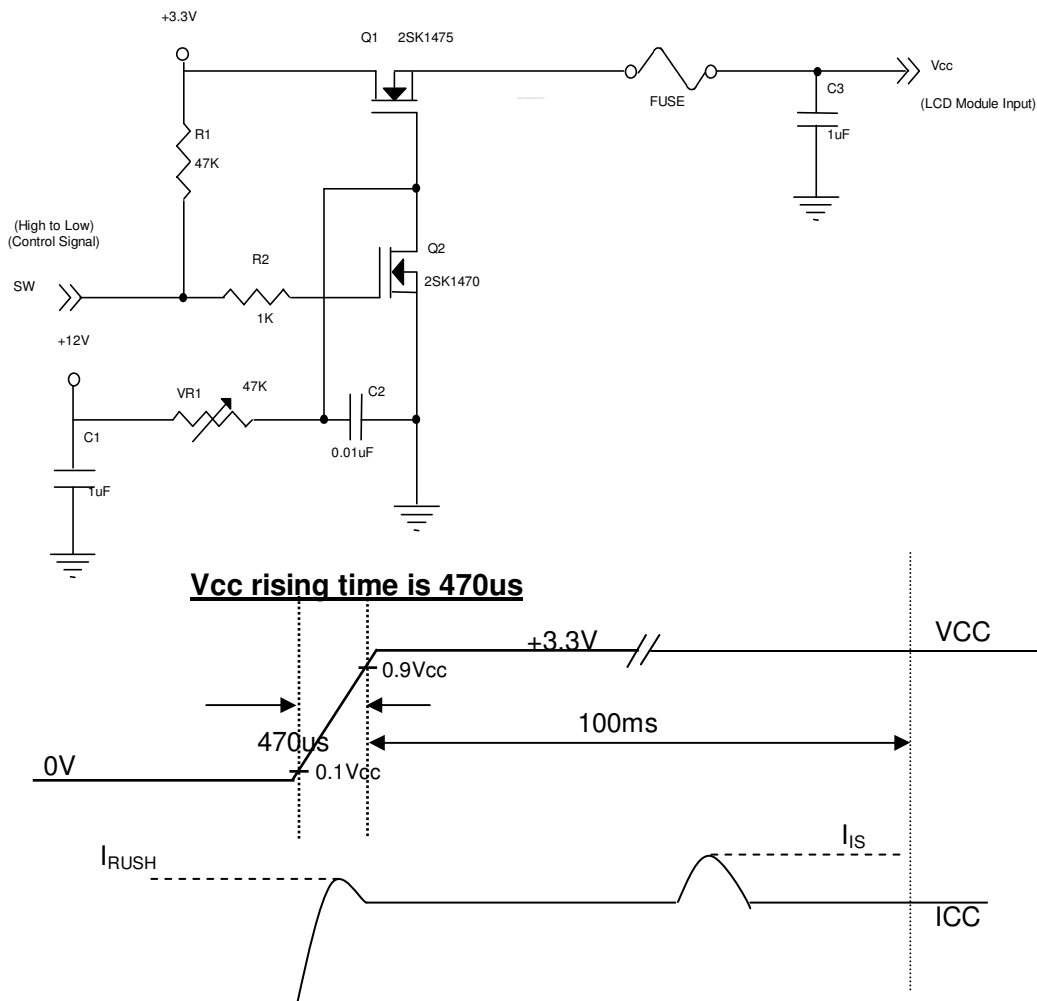

Note (3) The specified power supply current is under the conditions at  $V_{CC} = 3.3\text{ V}$ ,  $T_a = 25 \pm 2\text{ }^\circ\text{C}$ ,  $f_v = 60\text{ Hz}$ , whereas a power dissipation check pattern below is displayed.

a. White Pattern

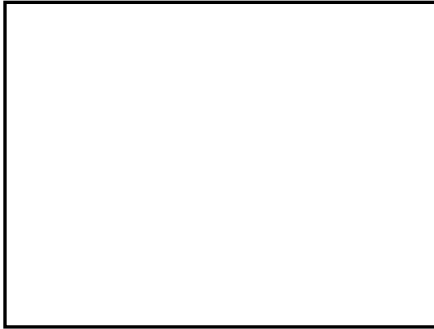

Active Area

b. Black Pattern



Active Area

Note (4) The specified power are the sum of LCD panel electronics input power and the converter input power. Test conditions are as follows.

- (a)  $V_{CC} = 3.3\text{ V}$ ,  $T_a = 25 \pm 2\text{ }^\circ\text{C}$ ,  $f_v = 60\text{ Hz}$ ,
- (b) The pattern used is a black and white 32 x 36 checkerboard, slide #100 from the VESA file "Flat Panel Display Monitor Setup Patterns", FPDMSU.ppt.
- (c) Luminance: 60 nits.
- (d) The converter used is provided from \_\_\_\_\_. Please contact them for detail information.  
 CMO doesn't provide the converter in this product.

Note (5) The parameters of LVDS signals are defined as the following figures.

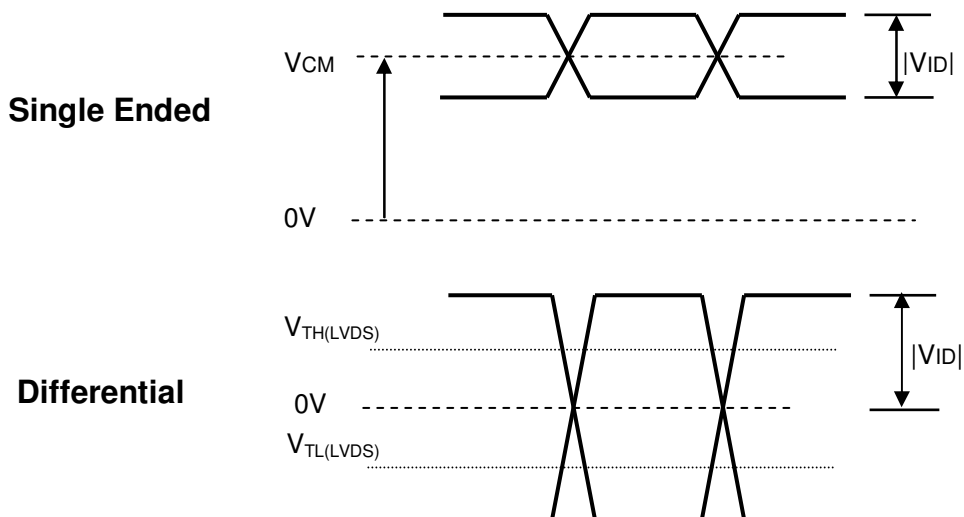



3.2 BACKLIGHT UNIT

Ta = 25 ± 2 °C

Parameter	Symbol	Value			Unit	Note
		Min.	Typ.	Max.		
LED Quantity		54			PCs	(1)
LED Light Bar Power Supply Voltage	V <sub>L</sub>	27	28.8	30.6	V	(1),(2) (Duty 100%)
LED Light Bar Power Supply Current	I <sub>L</sub>	--	120	--	mA	
Power Consumption	P <sub>L</sub>	--	3.46	--	W	(3), (Duty 100%)
LED Life Time	L <sub>BL</sub>	10000	--	--	Hrs	(4)

Note (1) LED light bar configuration is shown as below.

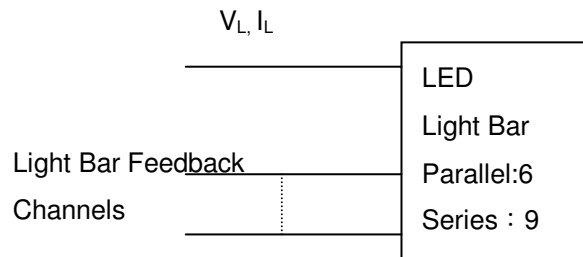

Note (2) For better LED light bar driving quality, it is recommended to utilize the adaptive boost converter with current balancing function to drive LED light-bar.

Note (3)  $P_L = I_L \times V_L$

Note (4) The lifetime of LED is defined as the time when it continues to operate under the conditions at Ta = 25 ± 2 °C and I<sub>L</sub> = 20 mA(Per EA) until the brightness becomes ≤ 50% of its original value.

4. BLOCK DIAGRAM

4.1 TFT LCD MODULE

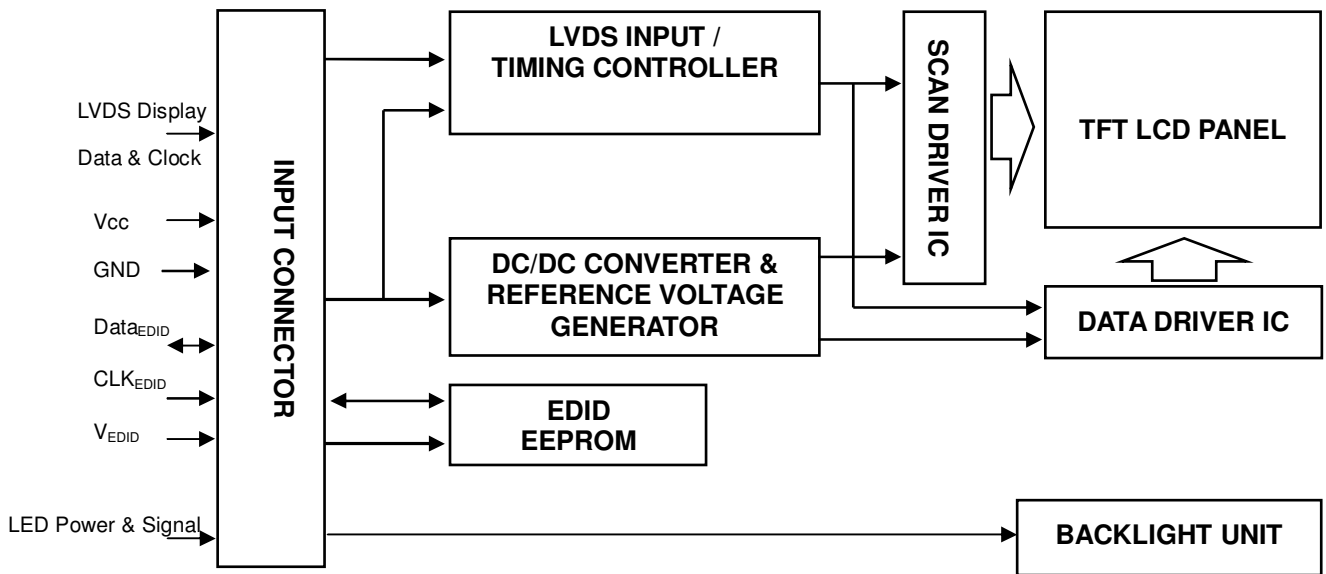

## 5. INPUT TERMINAL PIN ASSIGNMENT

### 5.1 TFT LCD MODULE

Pin	Symbol	Description	Polarity	Remark
1	Vss	Ground		
2	Vcc	Power Supply +3.3 V (typical)		
3	Vcc	Power Supply +3.3 V (typical)		
4	V <sub>EDID</sub>	DDC 3.3V Power		DDC 3.3V Power
5	NC	No connect		
6	CLK <sub>EDID</sub>	DDC Clock		DDC Clock
7	DATA <sub>EDID</sub>	DDC Data		DDC Data
8	Rxin0-	LVDS Differential Data Input	Negative	R0~R5,G0
9	Rxin0+	LVDS Differential Data Input	Positive	
10	Vss	Ground		
11	Rxin1-	LVDS Differential Data Input	Negative	G1~G5, B0, B1
12	Rxin1+	LVDS Differential Data Input	Positive	
13	Vss	Ground		
14	Rxin2-	LVDS Differential Data Input	Negative	B2~B5, DE, Hsync, Vsync
15	Rxin2+	LVDS Differential Data Input	Positive	
16	Vss	Ground		
17	CLK-	LVDS Clock Data Input	Negative	LVDS Level Clock
18	CLK+	LVDS Clock Data Input	Positive	
19	Vss	Ground		
20	Vss	Ground		
21	Vdc(1&2&3)	LED Annode (Positive)		
22	Vdc(4&5&6)	LED Annode (Positive)		
23	NC	No connect		
24	Vdc1	LED Cathode (Negative)		
25	Vdc2	LED Cathode (Negative)		
26	Vdc3	LED Cathode (Negative)		
27	Vdc4	LED Cathode (Negative)		
28	Vdc5	LED Cathode (Negative)		
29	Vdc6	LED Cathode (Negative)		
30	Vss	Ground		

Note (1) Connector Part No.: 20474-030E-12(I-PEX) or equivalent

Note (2) User's connector Part No.: 20472-030T-10(I-PEX) or equivalent

5.3 TIMING DIAGRAM OF LVDS INPUT SIGNAL

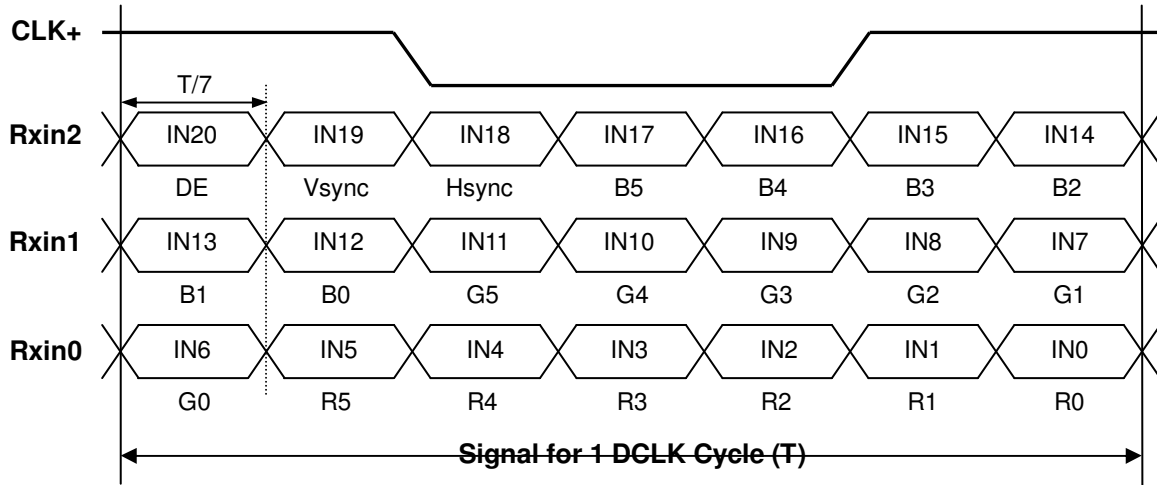

### 5.4 COLOR DATA INPUT ASSIGNMENT

The brightness of each primary color (red, green and blue) is based on the 6-bit gray scale data input for the color. The higher the binary input, the brighter the color. The table below provides the assignment of color versus data input.

Color		Data Signal																	
		Red						Green						Blue					
		R5	R4	R3	R2	R1	R0	G5	G4	G3	G2	G1	G0	B5	B4	B3	B2	B1	B0
Basic Colors	Black	0	0	0	0	0	0	0	0	0	0	0	0	0	0	0	0	0	0
	Red	1	1	1	1	1	1	0	0	0	0	0	0	0	0	0	0	0	0
	Green	0	0	0	0	0	0	1	1	1	1	1	1	0	0	0	0	0	0
	Blue	0	0	0	0	0	0	0	0	0	0	0	0	1	1	1	1	1	1
	Cyan	0	0	0	0	0	0	1	1	1	1	1	1	1	1	1	1	1	1
	Magenta	1	1	1	1	1	1	0	0	0	0	0	0	1	1	1	1	1	1
	Yellow	1	1	1	1	1	1	1	1	1	1	1	1	0	0	0	0	0	0
	White	1	1	1	1	1	1	1	1	1	1	1	1	1	1	1	1	1	1
Gray Scale Of Red	Red(0)/Dark	0	0	0	0	0	0	0	0	0	0	0	0	0	0	0	0	0	0
	Red(1)	0	0	0	0	0	1	0	0	0	0	0	0	0	0	0	0	0	0
	Red(2)	0	0	0	0	1	0	0	0	0	0	0	0	0	0	0	0	0	0
	:	:	:	:	:	:	:	:	:	:	:	:	:	:	:	:	:	:	:
	:	:	:	:	:	:	:	:	:	:	:	:	:	:	:	:	:	:	:
	:	:	:	:	:	:	:	:	:	:	:	:	:	:	:	:	:	:	:
	Red(61)	1	1	1	1	0	1	0	0	0	0	0	0	0	0	0	0	0	0
	Red(62)	1	1	1	1	1	0	0	0	0	0	0	0	0	0	0	0	0	0
Red(63)	1	1	1	1	1	1	0	0	0	0	0	0	0	0	0	0	0	0	
Gray Scale Of Green	Green(0)/Dark	0	0	0	0	0	0	0	0	0	0	0	0	0	0	0	0	0	0
	Green(1)	0	0	0	0	0	0	0	0	0	0	0	1	0	0	0	0	0	0
	Green(2)	0	0	0	0	0	0	0	0	0	0	1	0	0	0	0	0	0	0
	:	:	:	:	:	:	:	:	:	:	:	:	:	:	:	:	:	:	:
	:	:	:	:	:	:	:	:	:	:	:	:	:	:	:	:	:	:	:
	:	:	:	:	:	:	:	:	:	:	:	:	:	:	:	:	:	:	:
	Green(61)	0	0	0	0	0	0	1	1	1	1	0	1	0	0	0	0	0	0
	Green(62)	0	0	0	0	0	0	1	1	1	1	1	0	0	0	0	0	0	0
Green(63)	0	0	0	0	0	0	1	1	1	1	1	1	0	0	0	0	0	0	
Gray Scale Of Blue	Blue(0)/Dark	0	0	0	0	0	0	0	0	0	0	0	0	0	0	0	0	0	0
	Blue(1)	0	0	0	0	0	0	0	0	0	0	0	0	0	0	0	0	0	1
	Blue(2)	0	0	0	0	0	0	0	0	0	0	0	0	0	0	0	0	1	0
	:	:	:	:	:	:	:	:	:	:	:	:	:	:	:	:	:	:	:
	:	:	:	:	:	:	:	:	:	:	:	:	:	:	:	:	:	:	:
	:	:	:	:	:	:	:	:	:	:	:	:	:	:	:	:	:	:	:
	Blue(61)	0	0	0	0	0	0	0	0	0	0	0	0	1	1	1	1	0	1
	Blue(62)	0	0	0	0	0	0	0	0	0	0	0	0	1	1	1	1	1	0
Blue(63)	0	0	0	0	0	0	0	0	0	0	0	0	1	1	1	1	1	1	

Note (1) 0: Low Level Voltage, 1: High Level Voltage

## 5.5 EDID DATA STRUCTURE

The EDID (Extended Display Identification Data) data formats are to support displays as defined in the VESA Plug & Display and FPD/ standards.

Byte # (decimal)	Byte # (hex)	Field Name and Comments	Value (hex)	Value (binary)
0	0	Header	00	00000000
1	1	Header	FF	11111111
2	2	Header	FF	11111111
3	3	Header	FF	11111111
4	4	Header	FF	11111111
5	5	Header	FF	11111111
6	6	Header	FF	11111111
7	7	Header	00	00000000
8	8	EISA ID manufacturer name ("APP")	06	00000110
9	9	EISA ID manufacturer name (Compressed ASCII)	10	00010000
10	0A	ID product code (N13316-L02)	8b	10001011
11	0B	ID product code (hex LSB first; N13316-L02)	9C	10011100
12	0C	ID S/N (fixed "0")	00	00000000
13	0D	ID S/N (fixed "0")	00	00000000
14	0E	ID S/N (fixed "0")	00	00000000
15	0F	ID S/N (fixed "0")	00	00000000
16	10	Week of manufacture (fixed "27")	1B	00011011
17	11	Year of manufacture (fixed "2008")	12	00010010
18	12	EDID structure version # ("1")	01	00000001
19	13	EDID revision # ("3")	03	00000011
20	14	Video I/P definition ("digital")	80	10000000
21	15	Max H image size ("29.7cm")	1D	00011101
22	16	Max V image size ("19.2cm")	13	00010011
23	17	Display Gamma (Gamma = "2.2")	78	01111000
24	18	Feature support ("Active off, RGB Color")	0A	00001010
25	19	Red/Green (Rx1, Rx0, Ry1, Ry0, Gx1, Gx0, Gy1, Gy0)	5C	01011100
26	1A	Blue/White (Bx1, Bx0, By1, By0, Wx1, Wx0, Wy1, Wy0)	80	10000000
27	1B	Red-x (Rx = "0.595")	98	10011000
28	1C	Red-y (Ry = "0.345")	58	01011000
29	1D	Green-x (Gx = "0.320")	51	01010001
30	1E	Green-y (Gy = "0.555")	8E	10001110
31	1F	Blue-x (Bx = "0.155")	27	00100111
32	20	Blue-y (By = "0.145")	25	00100101
33	21	White-x (Wx = "0.313")	50	01010000
34	22	White-y (Wy = "0.329")	54	01010100
35	23	Established timings 1	00	00000000
36	24	Established timings 2 (1280x800@60Hz)	00	00000000
37	25	Manufacturer's reserved timings	00	00000000
38	26	Standard timing ID # 1	01	00000001
39	27	Standard timing ID # 1	01	00000001
40	28	Standard timing ID # 2	01	00000001
41	29	Standard timing ID # 2	01	00000001

42	2A	Standard timing ID # 3	01	00000001
43	2B	Standard timing ID # 3	01	00000001
44	2C	Standard timing ID # 4	01	00000001
45	2D	Standard timing ID # 4	01	00000001
46	2E	Standard timing ID # 5	01	00000001
47	2F	Standard timing ID # 5	01	00000001
48	30	Standard timing ID # 6	01	00000001
49	31	Standard timing ID # 6	01	00000001
50	32	Standard timing ID # 7	01	00000001
51	33	Standard timing ID # 7	01	00000001
52	34	Standard timing ID # 8	01	00000001
53	35	Standard timing ID # 8	01	00000001
54	36	Detailed timing description # 1 Pixel clock ("72.5MHz", According to VESA CVT Rev1.1)	52	01010010
55	37	# 1 Pixel clock (hex LSB first)	1C	00011100
56	38	# 1 H active ("1280")	00	00000000
57	39	# 1 H blank ("160")	A0	10100000
58	3A	# 1 H active : H blank ("1280 : 160")	50	01010000
59	3B	# 1 V active ("800")	20	00100000
60	3C	# 1 V blank ("23")	17	00010111
61	3D	# 1 V active : V blank ("800 :23")	30	00110000
62	3E	# 1 H sync offset ("48")	30	00110000
63	3F	# 1 H sync pulse width ("32")	20	00100000
64	40	# 1 V sync offset : V sync pulse width ("3 : 6")	36	00110110
65	41	# 1 H sync offset : H sync pulse width : V sync offset : V sync width ("48: 32 : 3 : 6")	00	00000000
66	42	# 1 H image size ("286.08 mm")	1E	00011110
67	43	# 1 V image size ("178.8 mm")	B2	10110010
68	44	# 1 H image size : V image size ("286 : 178")	10	00010000
69	45	# 1 H boarder ("0")	00	00000000
70	46	# 1 V boarder ("0")	00	00000000
71	47	# 1 Non-interlaced, Normal, no stereo, Separate sync, H/V pol Negatives	18	00011000
72	48	Detailed timing/monitor	00	00000000
73	49	descriptor #2	00	00000000
74	4A		00	00000000
75	4B		01	00000001
76	4C	Version	00	00000000
77	4D	Apple edid signature	06	00000110
78	4E	Apple edid signature	10	00010000
79	4F	Link Type (LVDS Link,MSB justified)	20	00100000
80	50	Pixel and link component format (6-bit panel interface)	00	00000000
81	51	Panel features (No inverter)	00	00000000
82	52		00	00000000
83	53		00	00000000
84	54		00	00000000
85	55		00	00000000
86	56		00	00000000

87	57		00	00000000
88	58		0A	00001010
89	59		20	00100000
90	5A	Detailed timing description # 3	00	00000000
91	5B	# 3 Flag	00	00000000
92	5C	# 3 Reserved	00	00000000
93	5D	# 3 FE (hex) defines ASCII string (Model Name "N13313-L01", ASCII)	FE	11111110
94	5E	# 3 Flag	00	00000000
95	5F	# 3 1st character of name ("N")	4E	01001110
96	60	# 3 2nd character of name ("1")	31	00110001
97	61	# 3 3rd character of name ("3")	33	00110011
98	62	# 3 4th character of name ("3")	33	00110011
99	63	# 3 5th character of name ("l")	49	01001001
100	64	# 3 6th character of name ("6")	36	00110110
101	65	# 3 7th character of name ("-")	2D	00101101
102	66	# 3 8th character of name ("L")	4C	01001100
103	67	# 3 9th character of name ("0")	30	00110000
104	68	# 3 9th character of name ("2")	32	00110010
105	69	# 3 New line character indicates end of ASCII string	0A	00001010
106	6A	# 3 Padding with "Blank" character	20	00100000
107	6B	# 3 Padding with "Blank" character	20	00100000
108	6C	Detailed timing description # 4	00	00000000
109	6D	# 4 Flag	00	00000000
110	6E	# 4 Reserved	00	00000000
111	6F	# 4 FC (hex) defines Monitor name ("Color LCD", ASCII)	FC	11111100
112	70	# 4 Flag	00	00000000
113	71	# 4 1st character of name ("C")	43	01000011
114	72	# 4 2nd character of name ("o")	6F	01101111
115	73	# 4 3rd character of name ("l")	6C	01101100
116	74	# 4 4th character of name ("o")	6F	01101111
117	75	# 4 5th character of name ("r")	72	01110010
118	76	# 4 6th character of name (<space>)	20	00100000
119	77	# 4 7th character of name ("L")	4C	01001100
120	78	# 4 8th character of name ("C")	43	01000011
121	79	# 4 9th character of name ("D")	44	01000100
122	7A	# 4 New line character # 4 indicates end of Monitor name	0A	00001010
123	7B	# 4 Padding with "Blank" character	20	00100000
124	7C	# 4 Padding with "Blank" character	20	00100000
125	7D	# 4 Padding with "Blank" character	20	00100000
126	7E	Extension flag	00	00000000
127	7F	Checksum	38	00111000



## 6. INTERFACE TIMING

### 6.1 INPUT SIGNAL TIMING SPECIFICATIONS

The specifications of input signal timing are as the following table and timing diagram.

Signal	Item	Symbol	Min.	Typ.	Max.	Unit	Note
DCLK	Frequency	1/Tc	50	71	80	MHz	-
DE	Vertical Total Time	TV	803	823	1028	TH	-
	Vertical Addressing Time	TVD	800	800	800	TH	-
	Vertical Active Blanking Period	TVB	TV-TVD	23	TV-TVD	TH	-
	Horizontal Total Time	TH	1362	1440	1800	Tc	-
	Horizontal Addressing Time	THD	1280	1280	1280	Tc	-
	Horizontal Active Blanking Period	THB	TH-THD	160	TH-THD	Tc	-

Note (1) Because this module is operated by DE only mode, Hsync and Vsync are ignored.

#### INPUT SIGNAL TIMING DIAGRAM

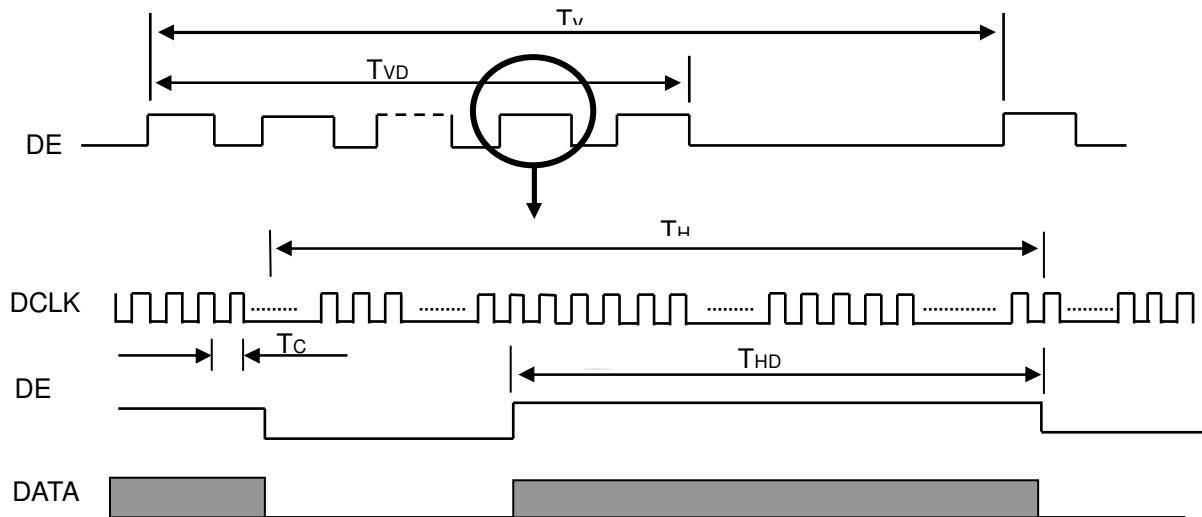

## 6.2 POWER ON/OFF SEQUENCE

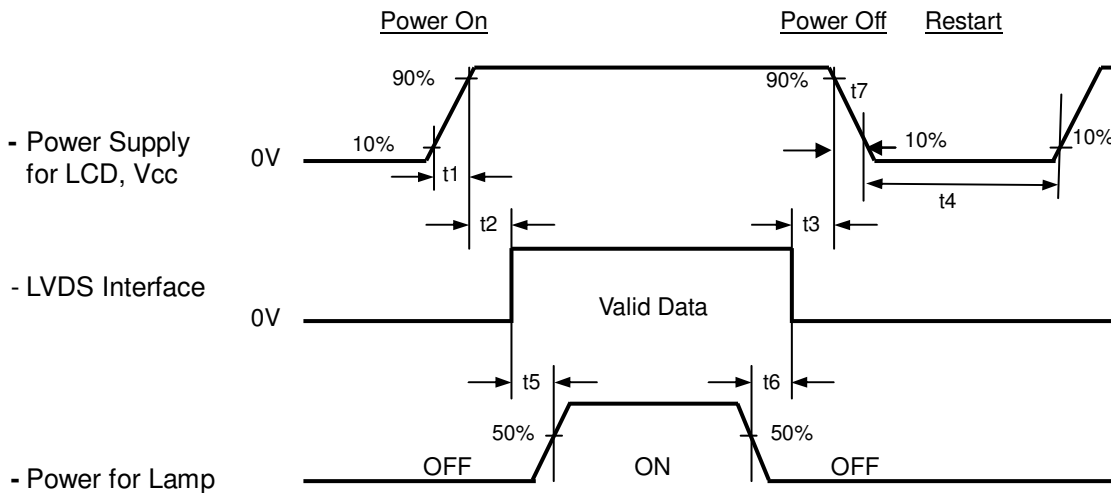

### Timing Specifications:

- $0.5 \leq t1 \leq 10 \text{ ms}$
- $0 \leq t2 \leq 50 \text{ ms}$
- $0 \leq t3 \leq 50 \text{ ms}$
- $t4 \geq 500 \text{ ms}$
- $t5 \geq 200 \text{ ms}$
- $t6 \geq 200 \text{ ms}$

Note (1) Please follow the power on/off sequence described above. Otherwise, the LCD module might be damaged.

Note (2) Please avoid floating state of interface signal at invalid period. When the interface signal is invalid, be sure to pull down the power supply of LCD Vcc to 0 V.

Note (3) The Backlight converter power must be turned on after the power supply for the logic and the interface signal is valid. The Backlight converter power must be turned off before the power supply for the logic and the interface signal is invalid.

Note (4) Sometimes some slight noise shows when LCD is turned off (even backlight is already off). To avoid this phenomenon, we suggest that the Vcc falling time is better to follow  $5 \leq t7 \leq 300 \text{ ms}$ .

## 7 OPTICAL CHARACTERISTICS

### 7.1 TEST CONDITIONS

Item	Symbol	Value	Unit
Ambient Temperature	T <sub>a</sub>	25±2	°C
Ambient Humidity	H <sub>a</sub>	50±10	%RH
Supply Voltage	V <sub>CC</sub>	3.3	V
Input Signal	According to typical value in "3. ELECTRICAL CHARACTERISTICS"		
LED Light Bar Input Current	I <sub>L</sub>	120	mA

The measurement methods of optical characteristics are shown in Section 7.2. The following items should be measured under the test conditions described in Section 7.1 and stable environment shown in Note (5).

### 7.2 OPTICAL SPECIFICATIONS

Item		Symbol	Condition	Min.	Typ.	Max.	Unit	Note
Contrast Ratio		CR	$\theta_x=0^\circ, \theta_y=0^\circ$ Viewing Normal Angle	400	500		-	(2), (5)
Response Time		T <sub>R</sub>		-	3	8	ms	(3)
		T <sub>F</sub>		-	7	12	ms	
Center Luminance of White		L <sub>ct</sub>		261	290		cd/m <sup>2</sup>	(4), (5)
Luminance Uniformity		U		50			%	(5), (8)
Color Chromaticity	Red	R <sub>x</sub>		0.575	0.595	0.615	-	(5)
		R <sub>y</sub>		0.325	0.345	0.365	-	
	Green	G <sub>x</sub>		0.300	0.320	0.340	-	
		G <sub>y</sub>		0.535	0.555	0.575	-	
	Blue	B <sub>x</sub>		0.135	0.155	0.175	-	
		B <sub>y</sub>		0.125	0.145	0.165	-	
	White	W <sub>x</sub>		0.297	0.313	0.329	-	
		W <sub>y</sub>		0.313	0.329	0.345	-	
Cross-talk		D <sub>SHA</sub>		-	-	2	%	(5), (6)
Color Difference w.r.t. center			-	-	0.003	-	(5), (9)	
Color Difference over panel			-	-	0.005	-	(5), (10)	
Color Difference worst neighbor			-	-	0.0025	-	(5), (11)	
Viewing Angle	Horizontal	$\theta_{x+}$	CR <sub>≥</sub> 10	40	45		Deg.	(1)
		$\theta_{x-}$		40	45			
	Vertical	$\theta_{y+}$		15	20			
		$\theta_{y-}$		40	45			

Note (1) Definition of Viewing Angle ( $\theta_x, \theta_y$ ):

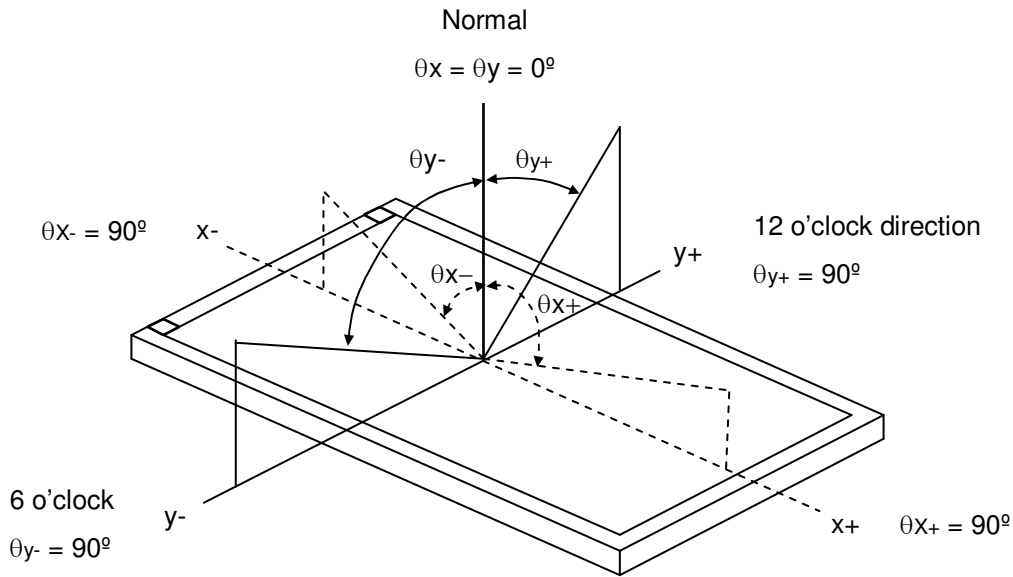

Note (2) Definition of Contrast Ratio (CR):

The contrast ratio can be calculated by the following expression.

$$\text{Contrast Ratio (CR)} = L_{63} / L_0$$

$L_{63}$ : Luminance of gray level 63

$L_0$ : Luminance of gray level 0

$$\text{CR} = \text{CR} (5)$$

CR (X) is corresponding to the Contrast Ratio of the point X at Figure in Note (7).

Note (3) Definition of Response Time ( $T_R, T_F$ ):

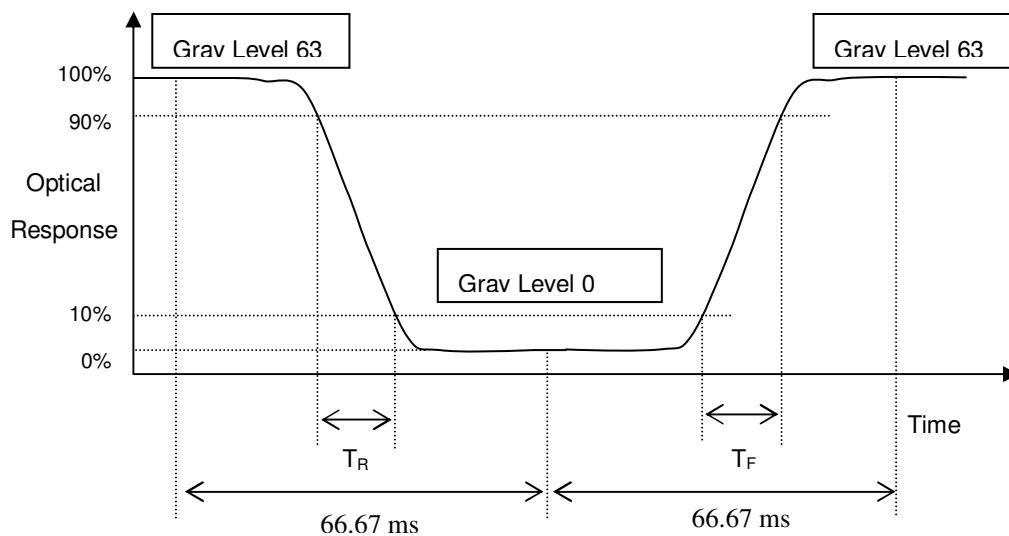

Note (4) Definition of Center Luminance of White ( $L_{ct}$ ):

Measure the luminance of gray level 63 at center points

$$L_{ct} = L(5)$$

$L(x)$  is corresponding to the luminance of the point X at Figure in Note (7).

Note (5) Measurement Setup:

The LCD module should be stabilized at given temperature for 15 minutes to avoid abrupt temperature change during measuring. In order to stabilize the luminance, the measurement should be executed after lighting Backlight for 15 minutes in a windless room.

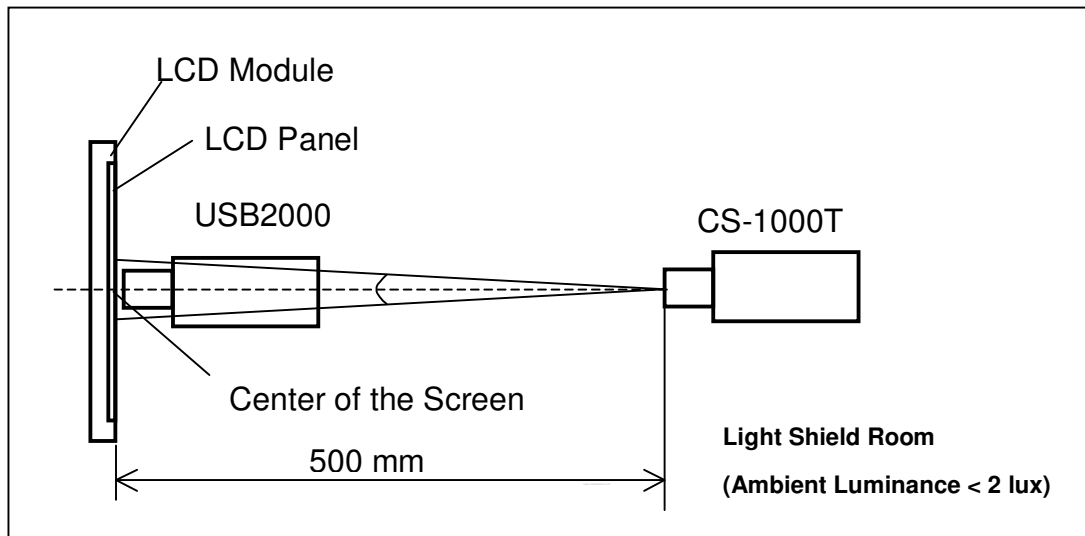

Note (6) Definition of Cross-talk ( $D_{SHA}$ )

$$D_{SHA} = |Y_B - Y_A| / Y_A \times 100 (\%)$$

Where:

$Y_A$  = Luminance of measured location without gray level 0 pattern ( $cd/m^2$ )

$Y_B$  = Luminance of measured location with gray level 0 pattern ( $cd/m^2$ )

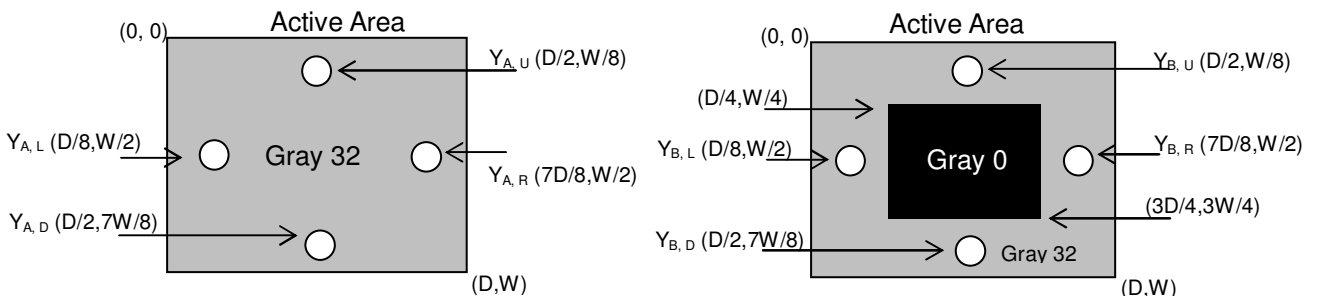

Note (7) Definition of measure point

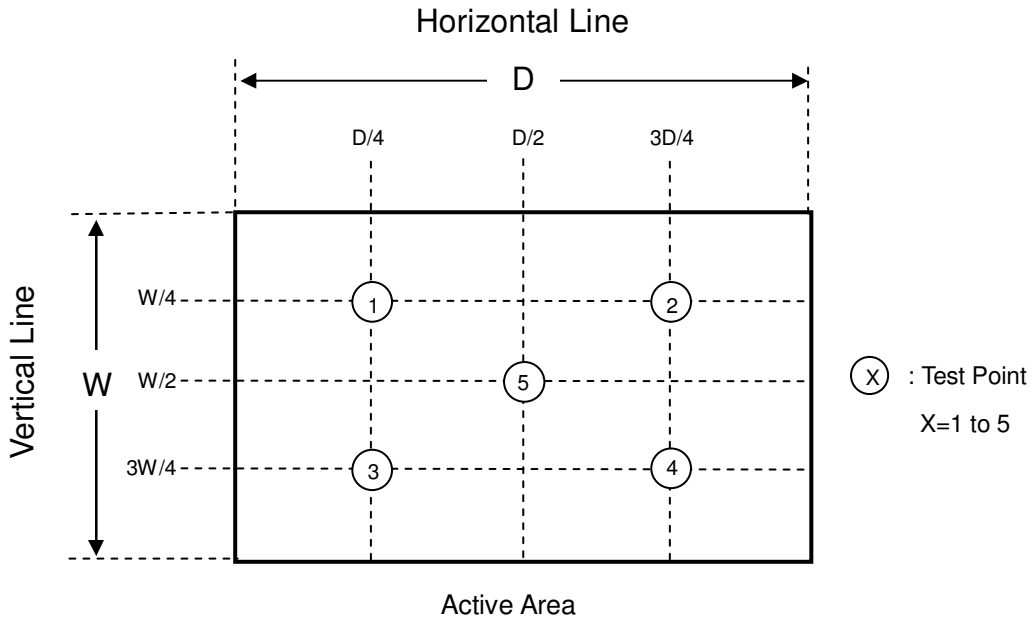

Note (8) Definition of Luminance Uniformity(U)

$$U = L_{min}/L_{max}$$

Where:

$L_{max} = \max \{ \text{Luminance values at 160 points} \}$ ,

$L_{min} = \min \{ \text{Luminance values at 160 points} \}$

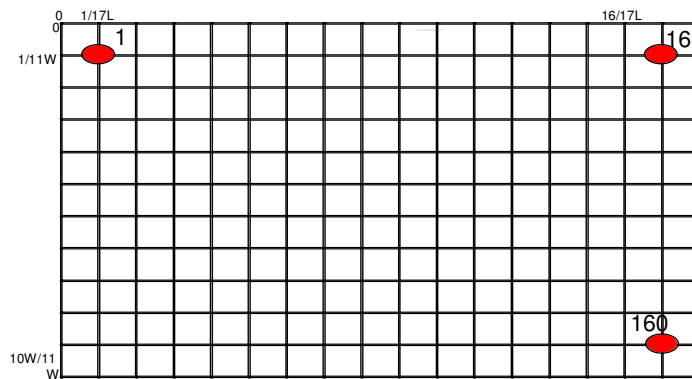

Note (9) Definition of Color Difference with respect to the center

Center color coordinate is defined as the Average of points of 72, 73, 88, 89. where is corresponding to the measured point in Note (8)

$$\text{Color Difference} = [(u'_x - u'_c)^2 + (v'_x - v'_c)^2]^{1/2}$$

Where x is any point in Note (8), c is the center point.

Note (10) Definition of Color Difference over the panel

Color Difference between any two measured points over the 160 points

$$=[(u'_x - u'_y)^2 + (v'_x - v'_y)^2]^{1/2}$$

Where x, y is any two points in Note (8)

Note (11) Definition of Color Difference between two neighbor

Color Difference between any two neighboring points on the panel

$$=[(u'_x - u'_y)^2 + (v'_x - v'_y)^2]^{1/2}$$

Where x, y is any two neighbor points in Note (8)

## 8. PRECAUTIONS

### 8.1 ASSEMBLY AND HANDLING PRECAUTIONS

- (1) Do not apply rough force such as bending or twisting to the module during assembly.
- (2) To assemble or install module into user's system can be only in clean working areas. The dust and oil may cause electrical short or worsen the polarizer.
- (3) It's not permitted to have pressure or impulse on the module because the LCD panel and Backlight will be damaged.
- (4) Always follow the correct power sequence when LCD module is connecting and operating. This can prevent damage to the CMOS LSI chips during latch-up.
- (5) Do not pull the I/F connector in or out while the module is operating.
- (6) Do not disassemble the module.
- (7) Use a soft dry cloth without chemicals for cleaning, because the surface of polarizer is very soft and easily scratched.
- (8) It is dangerous that moisture come into or contacted the LCD module, because moisture may damage LCD module when it is operating.
- (9) High temperature or humidity may reduce the performance of module. Please store LCD module within the specified storage conditions.
- (10) When ambient temperature is lower than 10°C may reduce the display quality. For example, the response time will become slowly, and the starting voltage of CCFL will be higher than room temperature.

### 8.2 SAFETY PRECAUTIONS

- (1) The startup voltage of Backlight is approximately 1000 Volts. It may cause electrical shock while assembling with converter. Do not disassemble the module or insert anything into the Backlight unit.
- (2) If the liquid crystal material leaks from the panel, it should be kept away from the eyes or mouth. In case of contact with hands, skin or clothes, it has to be washed away thoroughly with soap.
- (3) After the module's end of life, it is not harmful in case of normal operation and storage.

### 8.3 OPERATION PRECAUTIONS

- (1) Do not pull the I/F connector in or out while the module is operating.
- (2) Always follow the correct power on/off sequence when LCD module is connecting and operating. This can prevent the CMOS LSI chips from damage during latch-up.
- (3) The startup voltage of Backlight is approximately 1000 Volts. It may cause electrical shock while assembling with converter. Do not disassemble the module or insert anything into the Backlight unit.

## 9. PACKAGING

### 9.1 CARTON

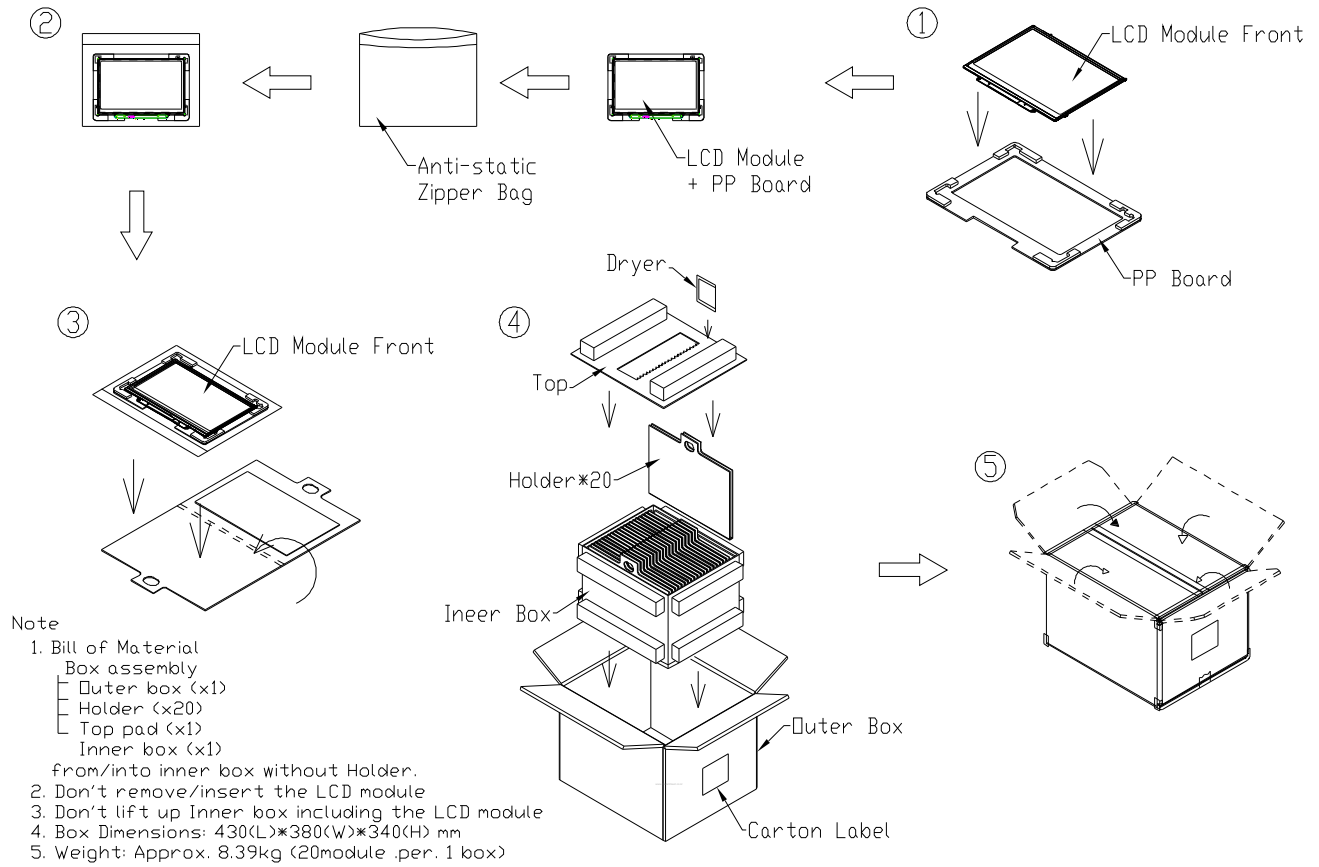

**Figure. 9-1 Packing method**



9.2 PALLET

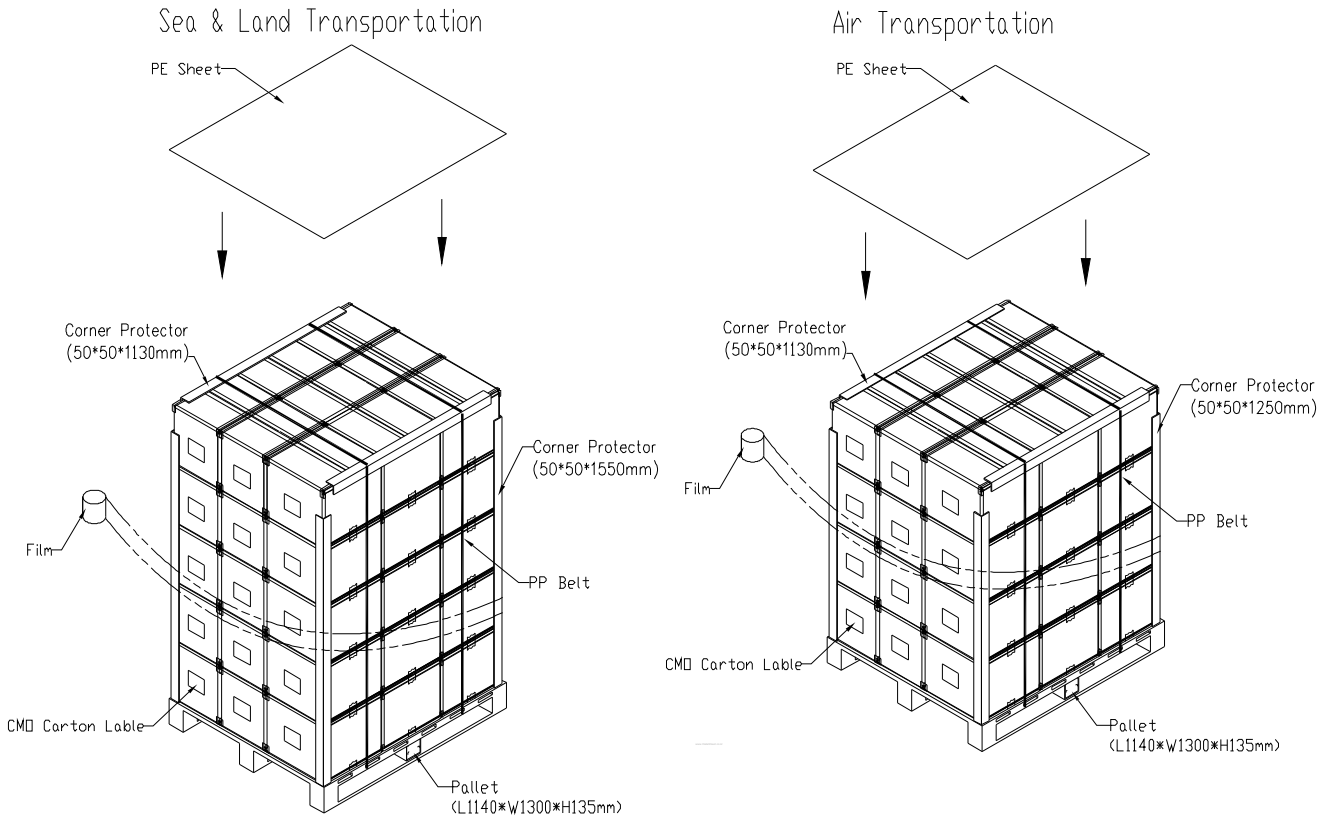

**Figure. 9-2 Packing method**

## 10. DEFINITION OF LABELS

### 10.1 CMO MODULE LABEL

The barcode nameplate is pasted on each module as illustration, and its definitions are as following explanation.



- (a) Model Name: N133I6 - L02
- (b) Revision: Rev. XX, for example: A1, ..., C1, C2 ...etc.
- (c) Serial ID: XXXXXXYMDXNNNN

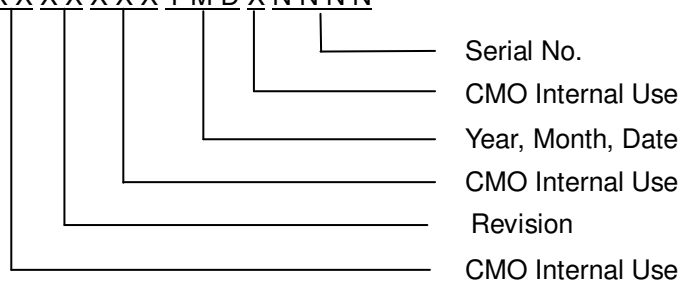

- (d) Production Location: MADE IN XXXX. XXXX stands for production location.

Serial ID includes the information as below:

- (a) Manufactured Date: Year: 1~9, for 2001~2009  
 Month: 1~9, A~C, for Jan. ~ Dec.  
 Day: 1~9, A~Y, for 1<sup>st</sup> to 31<sup>st</sup>, exclude I , O and U
- (b) Revision Code: cover all the change
- (c) Serial No.: Manufacturing sequence of product

10.2 CMO CARTON LABEL

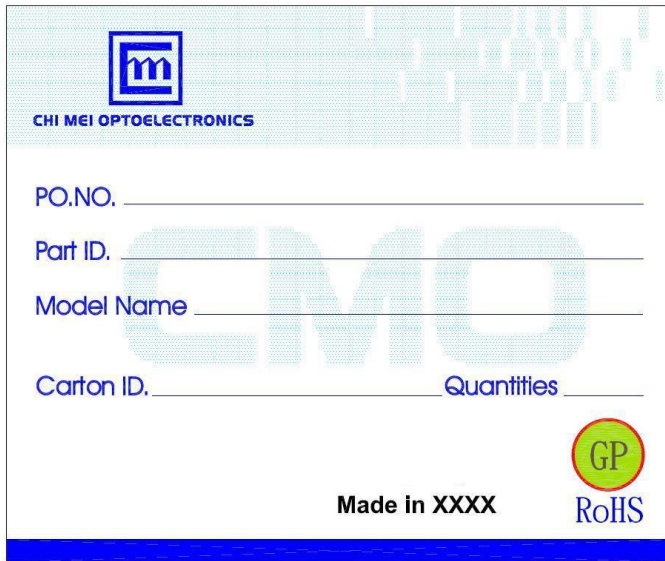

The image shows a template for a CMO carton label. It features a header with the CHI MEI logo and company name. Below this, there are four lines for inputting information: PO.NO., Part ID., Model Name, and Carton ID. The word 'CMO' is printed in large, light blue letters across the middle. At the bottom, there is a 'Made in XXXX' field and a RoHS compliance logo (a green circle with 'GP' inside) and the text 'RoHS'.

CHI MEI OPTOELECTRONICS

PO.NO. \_\_\_\_\_

Part ID. \_\_\_\_\_

Model Name \_\_\_\_\_

Carton ID. \_\_\_\_\_ Quantities \_\_\_\_\_

Made in XXXX

 RoHS