



M.S.KENNEDY CORP.

HIGH EFFICIENCY, HIGH VOLTAGE 4 AMP SURFACE MOUNT SWITCHING REGULATORS

5045 SERIES

4707 Dey Road Liverpool, N.Y. 13088

(315) 701-6751

FEATURES:

- Up To 88% Efficiency For 5V Version
- 4 Amp Output Current
- 1.2 x Vout to 80V Input Range with Separate Bias
- 12V to 80V Input Range with UVLO (VBias = VIN)
- Preset 2.5V, 3.3V or 5.0V Output Versions
- 300KHz Switching Frequency @ 1 Amp
- User Programmable Soft-Start
- User Programmable Current Limit
- Hermetic Package
- -55° C to + 125° C Operating Temperature Range
- Available with Gull Wing Leads
- Contact MSK for MIL-PRF-38534 Qualification Status

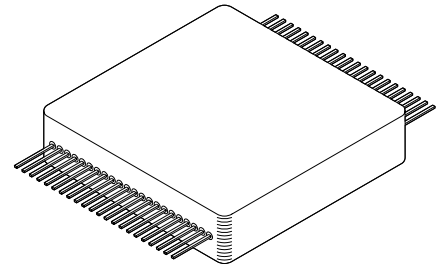

DESCRIPTION:

The MSK 5045 series are high efficiency, 4 amp, surface mount switching regulators. The output voltage is configured for 2.5V, 3.3V or 5.0V internally with a tolerance of 1% at 1.5 amps. The operating frequency of the MSK 5045 is 300KHz. An external "soft start" capacitor allows the user to control how quickly the output comes up to regulation voltage after the application of an input. A low quiescent current and greater than 85% operating efficiency keep the total internal power dissipation of the MSK 5045 down to an absolute minimum. The input circuitry has been designed to withstand a very wide range of voltages from less than 12V to as high as 80V. The device is packaged in a hermetic kovar flatpack for high reliability applications, and is available screened to MIL-PRF-38534 Class H.

EQUIVALENT SCHEMATIC

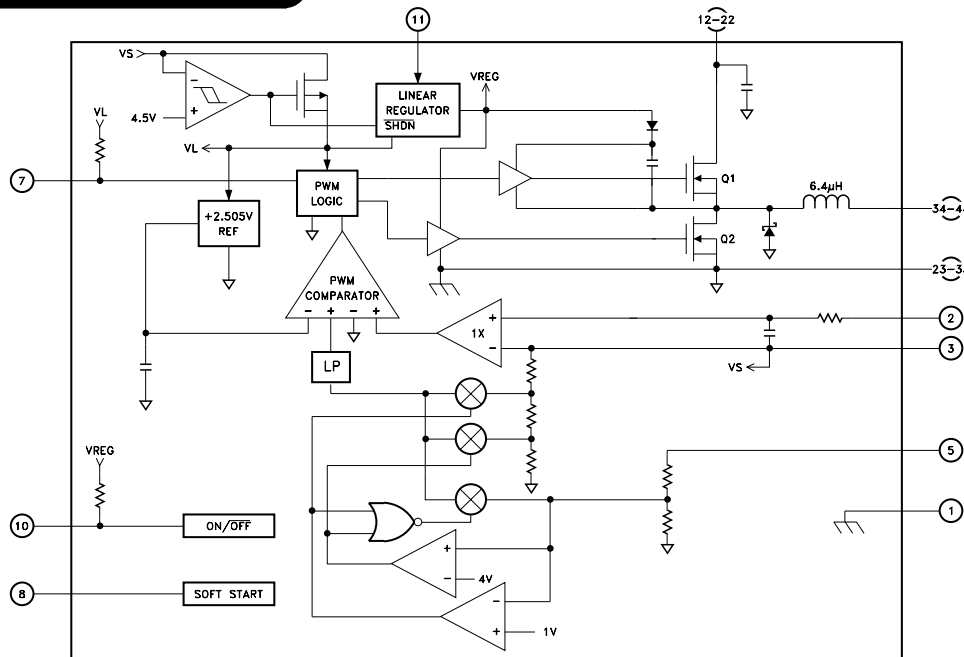

TYPICAL APPLICATIONS

- Step-down Switching Regulator
- Microprocessor Power Source
- High Efficiency Low Voltage Subsystem Power Supply

PIN-OUT INFORMATION

1	Case	34-44	VOUT
2	Sense High	23-33	Ground
3	Sense Low	12-22	VIN
4	NC	11	VBias
5	RFB	10	Enable
6	NC	9	NC
7	PWR SAVE	8	CTON

ABSOLUTE MAXIMUM RATINGS ^⑪

Input Voltage -0.3V, +80V
 Enable -0.3V, 10.5V
 PWR SAVE -0.3V, 5.5V
 Output Current 4.0 Amps
 Sense Pin Voltage -0.3V, +7V
 Thermal Resistance (@ 125°C)
 (Each MOSFET) 15°C/W

T_{ST} Storage Temperature Range -65°C to +150°C
 T_{LD} Lead Temperature Range 300°C
 (10 Seconds)
 T_C Case Operating Temperature
 MSK5045 Series -40°C to +85°C
 MSK5045H/E Series -55°C to +125°C
 T_J Junction Temperature +150°C

ELECTRICAL SPECIFICATIONS

Parameter	Test Conditions ^①	Group A Subgroup	MSK 5045 H/E SERIES			MSK 5045 SERIES			Units
			Min.	Typ.	Max.	Min.	Typ.	Max.	
V _{IN} Input Supply Range ^⑩		1,2,3	Note 10	28	80	Note 10	28	80	V
V _{Bias} Input Supply Range ^② ^⑨		1,2,3	12	28	80	12	28	80	V
V _{Bias} Current	V _{IN} =1.5x(V _{OUT}) V _{BIAS} =15V I _{OUT} =2A	1	12	19	35	12	19	35	mA
Under Voltage Lockout	Input Rising	1	7.4	10.0	12.0	7.3	10.0	12.0	V
	Input Falling	1	7.0	9.7	11.7	6.9	9.7	11.7	V
Output Voltage 5045-2.5 ^⑧	I _{OUT} = 1.5A	1	2.47	2.5	2.55	2.45	2.5	2.55	V
		2,3	2.38	2.5	2.63	-	-	-	V
Output Voltage 5045-3.3 ^⑧	I _{OUT} = 1.5A	1	3.27	3.3	3.33	3.23	3.3	3.37	V
		2,3	3.14	3.3	3.47	-	-	-	V
Output Voltage 5045-5.0 ^⑧	I _{OUT} = 1.5A	1	4.95	5.0	5.05	4.9	5.0	5.1	V
		2,3	4.75	5.0	5.25	-	-	-	V
Output Current ^②	Within SOA	1	4.0	4.2	-	4.0	4.2	-	A
Load Regulation	0.75A ≤ I _{OUT} ≤ 2.5A	1	-	0.5	1.5	-	0.5	2.0	%
		2,3	-	0.5	2.5	-	-	-	%
Line Regulation	I _{OUT} = 1.5A 12V ≤ V _{IN} ≤ 40V	1	-	0.5	1.5	-	0.5	2.0	%
		2,3	-	0.5	2.5	-	-	-	%
Oscillator Frequency ^② ^⑦	I _{OUT} ≥ 1.5A	4	270	300	330	270	300	330	KHz
Enable Input Voltage ^②	Open Circuit Voltage	1,2,3	9.6	12.8	15.5	9.6	12.8	15.5	V
	Low	1,2,3	-	-	0.5	-	-	0.5	V
Enable Input Current ^②	V _{EN} = 0V	1	-	120	200	-	120	200	µA
PWR SAVE Input Voltage ^②	Open Circuit Voltage	1,2,3	3.0	3.4	5.5	3.0	3.4	5.5	V
	Low	1,2,3	-	-	0.5	-	-	0.5	V
PWR SAVE Input Current ^②	V _{PWR SAVE} = 0V	1	-	100	200	-	100	200	µA
Disabled Quiescent Current	V _{EN} = 0V	1	-	1	2.5	-	1	2.5	mA
Current Limit Threshold ^②	Positive	1	80	100	120	75	100	125	mV
	Negative	1	-50	-100	-160	-45	-100	-165	mV
C _{ton} Current ^②	Source	1	2.5	4.0	6.5	2.5	4.0	6.5	µA
	Fault Sink	1	2.0	-	-	2.0	-	-	mA
Efficiency	5045-2.5	V _{IN} = 16V I _{OUT} = 1.5A	-	-	83	-	83	-	%
	5045-3.3	V _{IN} = 16V I _{OUT} = 1.5A	-	-	85	-	85	-	%
	5045-5.0	V _{IN} = 16V I _{OUT} = 1.5A	-	-	87	-	87	-	%

NOTES:

- ① V_{IN} = V_{Bias} = 28V, 5mV ≤ (sense high-sense low) ≤ 75mV, I_L = 0A, Enable = NC, PWR SAVE = NC C_{OUT} = 6x220µF, C_{IN} = 1x250µF + 4x10µF, C_{TON} = 0.01µF unless otherwise specified.
- ② Guaranteed by design but not tested. Typical parameters are representative of actual device performance but are for reference only.
- ③ All output parameters are tested using a low duty cycle pulse to maintain T_J = T_C.
- ④ Industrial grade and 'E' suffix devices shall be tested to subgroup 1 unless otherwise specified.
- ⑤ Military grade devices ('H' suffix) shall be 100% tested to subgroups 1,2 and 3.
- ⑥ Subgroup 1 T_A = T_C = +25°C
 Subgroup 2 T_A = T_C = +125°C
 Subgroup 3 T_A = T_C = -55°C
- ⑦ Actual switching frequency is load dependent if output current is low and sense resistor is large or zero. Refer to typical performance curves.
- ⑧ Alternate output voltages are available. Please contact the factory.
- ⑨ The device can withstand input voltages as high as 80V, but efficiency is best at lower inputs.
- ⑩ With V_{Bias} (pin 11) connected to a separate source, V_{IN} Min. is V_{OUT} + V_{DROPOUT}; see dropout curves.
- ⑪ Continuous operation at or above absolute maximum ratings may adversely effect the device performance and/or life cycle.

APPLICATION NOTES

INPUT BIAS AND UVLO:

Pin 11 of the MSK 5045 provides bias to an internal linear regulator that powers the control circuitry. The Vbias pin can be connected directly to the input bus for 12V to 80V operation or it can be biased separately with a 12V to 15V source to extend the input range of the device and improve efficiency at high line; refer to the paragraph titled "INPUT VOLTAGE RANGE". Vbias must be applied simultaneous with or prior to the input voltage. The MSK 5045's built in under voltage lock-out feature prevents damage to downstream devices in the event of a drop in bias voltage. Under voltage lockout occurs at bias voltages of approximately 10V rising and 9.7V falling. When separating the bias voltage from Vin to extend the input range below the Vbias UVLO set point, a simple open collector circuit can disable the device at any desired set point for Vin if UVLO is required. The internal bias draws approximately 30mA under normal operation and less than 10mA in Power Save mode with a light load on the output.

INPUT VOLTAGE RANGE

The MSK 5045's wide input range of 12V to 80V can be further extended down to VOUT + VDROPOUT by using a separate bias supply; refer to the paragraph titled "LOW VOLTAGE OPERATION". In this configuration very efficient low V to low V conversion can be achieved. At high line voltages the internal linear regulator dissipates more power than at low line. This loss in efficiency can be eliminated with a separate bias supply pushing the high line efficiency up close to the low line performance. Output ripple changes with line voltage; refer to the paragraph titled "OUTPUT INDUCTOR (OPTIONAL)" for more information.

SELECTING RS:

The MSK 5045 monitors the inductor current and the average load current by sensing the voltage across RS. Cycle-by-cycle current limiting is controlled with an upper threshold of 100mV ± 20mV; the high side MOSFET switch is gated off whenever the upper threshold is exceeded. Pulse skipping occurs in power save mode when the signal falls below the 30% current threshold of 30mV. The synchronous rectifier is disabled when the signal falls below 0V indicating discontinuous inductor current. Selection of RS must take all of these features into consideration.

When operated in the continuous conduction mode peak to peak inductor current is approximated by the equation

$$\left[\frac{(V_{IN}-V_{OUT}) \cdot V_{OUT}}{f \cdot L \cdot V_{IN}} \right]$$

where $f = 300\text{KHz}$ and $L = 6.4\mu\text{H}$. (If optional output inductance is used $L = 6.4\mu\text{H} + \text{optional } L$). The device will operate in continuous conduction as long as $I_{OUT} \geq \frac{1}{2} I_{p-p}$. The maximum and minimum current peaks are equal to $I_{OUT} \pm \frac{1}{2} I_{p-p}$. RS translates the current levels into the control signal. Once the current levels are established the designer can size RS for specific applications. Care must be taken when selecting RS because under a short circuit condition the output current will approach the cycle-by-cycle current limit.

For most applications, it may be useful to wire the sense inputs with a twisted pair instead of PCB traces. Low inductance current sense resistors, such as metal film surface mount styles are best.

SOFT START/Cton:

The internal soft-start circuitry allows a gradual increase of the internal current-limit level at start-up for the purpose of reducing input surge currents, and possibly for power-supply sequencing. In Disable mode, the soft-start circuit holds the Cton capacitor discharged to ground. When Enable goes high, a 4μA current source charges the Cton capacitor up to 3.2V. The resulting linear ramp causes the internal current-limit threshold to increase proportionally from 20mV to 100mV. The output capacitors charge up relatively slowly, depending on the Cton capacitor value. The exact time of the output rise depends on output capacitance and load current and is typically 1mS per nanofarad of soft-start capacitance. With no capacitor connected, maximum current limit is reached typically within 10μS.

POWER DISSIPATION:

In high current applications, it is very important to ensure that both MOSFETS are within their maximum junction temperature at high ambient temperatures. Temperature rise can be calculated based on package thermal resistance and worst case dissipation for each MOSFET. These worst case dissipations occur at minimum voltage for the high side MOSFET and at maximum voltage for the low side MOSFET.

Calculate power dissipation using the following formulas:

$$P_d (\text{upper FET}) = I_{LOAD}^2 \times 0.090\Omega \times \text{DUTY} + V_{IN} \times I_{LOAD} \times f \times \left[\frac{V_{IN} \times C_{RSS} + 25\text{ns}}{I_{GATE}} \right]$$

$$P_d (\text{lower FET}) = I_{LOAD}^2 \times 0.090\Omega \times (1-\text{DUTY})$$
$$\text{DUTY} = \left[\frac{(V_{OUT} + V_{Q2})}{(V_{IN} - V_{Q1})} \right]$$

$$\text{Where: } V_{Q1} \text{ or } V_{Q2} (\text{on state voltage drop}) = I_{LOAD} \times 0.090\Omega$$
$$C_{RSS} = 65\text{pF}$$
$$I_{GATE} = 2\text{A}$$

During output short circuit, Q2, the synchronous-rectifier MOSFET, will have an increased duty factor and will see additional stress. This can be calculated by:

$$Q2 \text{ DUTY} = 1 - \left[\frac{V_{Q2}}{V_{IN(\text{MAX})} - V_{Q1}} \right]$$

$$\text{Where: } V_{Q1} \text{ or } V_{Q2} = (120\text{mV}/R_{SENSE}) \times 0.090$$

INPUT CAPACITOR SELECTION:

The MSK 5045 should have an external high frequency ceramic capacitor (0.1μF) between VIN and GND. Connect a low-ESR bulk capacitor directly to the input pin of the MSK 5045. Select the bulk input filter capacitor according to input ripple-current requirements and voltage rating, rather than capacitor value. Electrolytic capacitors that have low enough ESR to meet the ripple-current requirement invariably have more than adequate capacitance values. Aluminum-electrolytic capacitors are preferred over tantalum types, which could cause power-up surge-current failure when connecting to robust AC adapters or low-impedance batteries. RMS input ripple current is determined by the input voltage and load current, with the worst possible case occurring at $V_{IN} = 2 \times V_{OUT}$:

$$I_{RMS} = I_{LOAD} \times \frac{\sqrt{V_{OUT}(V_{IN}-V_{OUT})}}{V_{IN}}$$

OUTPUT CAPACITOR SELECTION:

The output capacitor values are generally determined by the ESR and voltage rating requirements rather than capacitance requirements for stability. Low ESR capacitors that meet the ESR requirement usually have more output capacitance than required for stability. Only specialized low-ESR capacitors intended for switching-regulator applications, such as AVX TPS, Sprague 595D, Sanyo OS-CON, Nichicon PL series or Kemet T510 series should be used. The capacitor must meet minimum capacitance and maximum ESR values as given in the following equations:

$$C_f > \frac{2.5V(1 + V_{OUT}/V_{IN(MIN)})}{V_{OUT} \times R_{SENSE} \times f}$$

$$RESR < \frac{R_{SENSE} \times V_{OUT}}{2.5V}$$

These equations provide 45 degrees of phase margin to ensure jitter-free fixed-frequency operation and provide a damped output response for zero to full-load step changes. Lower quality capacitors can be used if the load lacks large step changes. Bench testing over temperature is recommended to verify acceptable noise and transient response. As phase margin is reduced, the first symptom is timing jitter, which shows up in the switching waveforms. Technically speaking, this typically harmless jitter is unstable operation, since the switching frequency is non-constant. As the capacitor ESR is increased, the jitter becomes worse. Eventually, the load-transient waveform has enough ringing on it that the peak noise levels exceed the output voltage tolerance. With zero phase margin and instability present, the output voltage noise never gets much worse than $I_{PEAK} \times RESR$ (under constant loads). Designers of industrial temperature range digital systems can usually multiply the calculated ESR value by a factor of 1.5 without hurting stability or transient response.

The output ripple is usually dominated by the ESR of the filter capacitors and can be approximated as $I_{RIPPLE} \times RESR$. Including the capacitive term, the full equation for ripple in the continuous mode is $V_{NOISE(p-p)} = I_{RIPPLE} \times (RESR + 1/(2\pi fC))$. In pulse skipping mode, the inductor current becomes discontinuous with high peaks and widely spaced pulses, so the noise can actually be higher at light load compared to full load. In pulse skipping mode, the output ripple can be calculated as follows:

$$V_{NOISE(p-p)} = \frac{0.02 \times RESR}{R_{SENSE}} + \frac{0.0003 \times 6.4\mu H \times [1/V_{OUT} + 1/(V_{IN} - V_{OUT})]}{(R_{SENSE})^2 \times C}$$

ENABLE FUNCTION:

The MSK 5045 is enabled by applying a logic level high to the Enable pin or leaving it open. A logic level low will disable the device and quiescent input current will reduce to approximately 1mA. The Enable threshold voltage is 1V. If automatic start up is required, simply make no connection. Maximum Enable voltage is + 10.5V. The Enable pin has an internal pull up resistor to 10.5V.

CURRENT LIMITING:

Current limiting the MSK5045 is achieved by setting the cycle-by-cycle current limit as described in the section titled SELECTING RS. The designer must set the peak current limit such that the average output current will not exceed the application limits. In a short circuit condition the average output current will approach the peak current limit. RS should be selected such that the average output current will not exceed 4.0 Amps. RS must be small enough to allow for the required load current plus the peak ripple current; $80mV/RS = I_{OUT} + \frac{1}{2}I_{p-p}$. Load components should be sized to withstand a maximum current of $120mV/RS$

OUTPUT INDUCTOR (OPTIONAL):

Placing an output inductor between the package and the sense resistor will reduce output ripple and noise. Output ripple and noise increase as the input to output voltage differential increases. Output ripple is also higher when the MSK 5045 is operated in power save mode. Optional inductance will directly add to the internal inductance of the device and should be included in peak to peak current calculations (see SELECTING RS). Since additional inductance will affect the output response of the regulator, the inductance value must be carefully selected for each application.

RFB:

It is very important that the DC voltage returned to the RFB pin from the output be as noise and oscillation free as possible. This voltage helps to determine the final output and therefore must be a clean voltage. Excessive noise or oscillation can cause the device to have an incorrect output voltage. Proper PC board layout techniques can help to achieve a noise free voltage at the RFB pin.

POWER SAVE MODE:

Power save mode is enabled by applying a logic low to the PWR SAVE pin and disabled by applying a logic high or leaving it open. The MSK5045 will skip switching pulses to save gate drive current in Q1 and Q2 when operated under light load with power save enabled. MSK5045 senses the voltage across RS and skips most switching pulses when the voltage falls below 30mV indicating a light load condition. The oscillator is gated off because the minimum current comparator resets the high side latch at the start of each cycle until the voltage feedback signal falls below the output voltage set point. Under heavy loads the voltage across RS does not fall below 30mV and the MSK5045 operates in full PWM mode at 300 KHz.

Disabling the power save mode sets the PWM to 300KHz constant switching frequency for low noise mode operation. Maximum input voltage on the PWR SAVE pin is 5.5V. The PWR SAVE pin has an internal pull-up resistor to 5V. RS should not be eliminated when power save is disabled because it provides cycle-by-cycle current limiting and synchronous rectifier control as described in the SEQUENCE OF OPERATION paragraph. Refer to table 1 for power save mode operational characteristics.

LOW VOLTAGE OPERATION

The MSK 5045 is capable of low voltage to low voltage conversion with up to 90% efficiency. A 5V bus can be stepped down to 3.3V or 2.5V with greater efficiency than linear conversion. Using an external bias supply the input voltage can be as low as V_{OUT} plus $V_{DROPOUT}$; consult the dropout curves for typical dropout voltages. Low line regulation error is easily trimmed with a low value feedback resistor in series with the RFB pin (5). Since the input current of the pin is approximately 250uA the output will increase by approximately 25mV per 100 ohms of resistance. The resistor should be selected such that the output voltage does not exceed the nominal output by more than 0.25V under the high input condition. Placing the feedback resistor as close to the device pin as possible helps to maintain noise immunity.

SEQUENCE OF OPERATION

Each pulse from the oscillator sets the internal PWM latch that turns on the high-side MOSFET. As the high-switch turns off, the synchronous rectifier latch is set. 60ns later the low-side MOSFET turns on until the start of the next clock cycle or until the inductor current crosses zero. Under fault conditions the current exceeds the $\pm 100mV$ current-limit threshold and the high-side switch turns off. Under light load conditions the synchronous rectifier is gated off as the inductor current falls through zero.

**TABLE 1
OPERATIONAL CHARACTERISTICS**

PWR SAVE	ENABLE	LOAD	DESCRIPTION
X	0	X	DEVICE DISABLED
0	1	LOW < 10%	PULSE SKIPPING MODE DISCONTINUOUS INDUCTOR CURRENT
0	1	MED < 30%	PULSE SKIPPING MODE CONTINUOUS INDUCTOR CURRENT
0	1	HIGH > 30%	CONSTANT FREQ. PWM MODE CONTINUOUS INDUCTOR CURRENT
1	1	X	LOW NOISE CONSTANT FREQ. MODE

TYPICAL 2.5V APPLICATION CIRCUIT

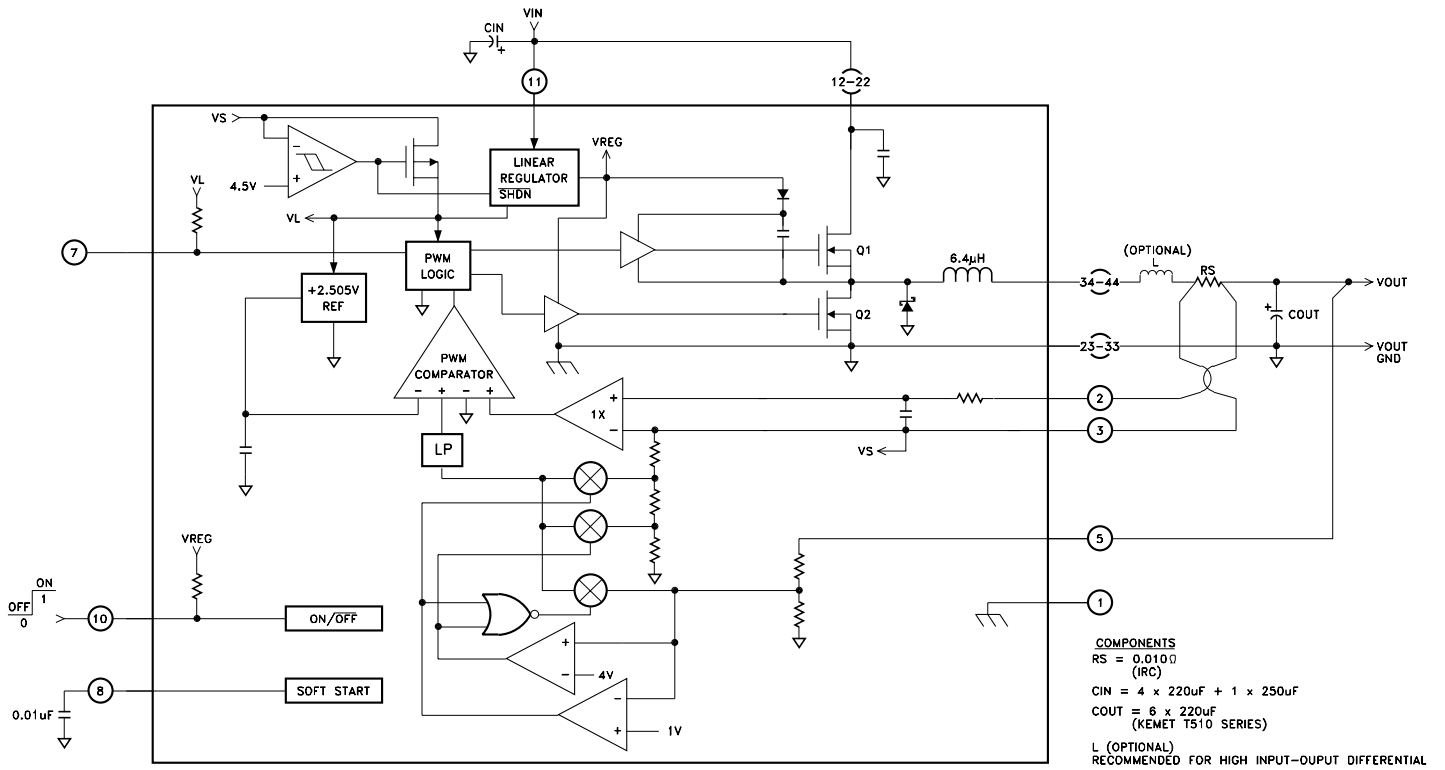

TYPICAL PERFORMANCE CURVES

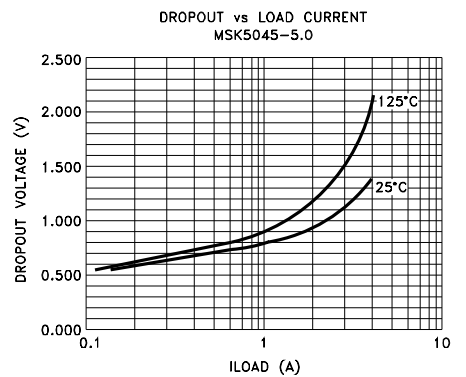
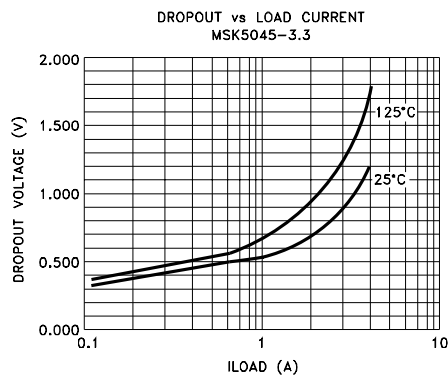
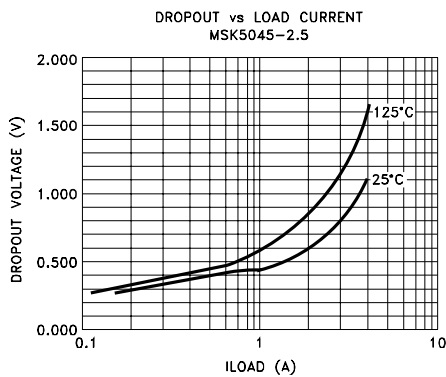

TYPICAL PERFORMANCE CURVES CONT'D

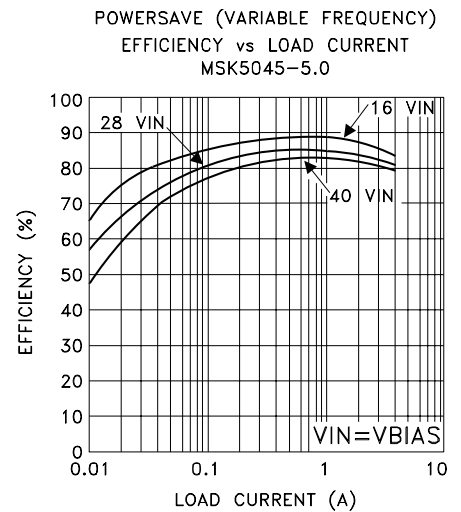
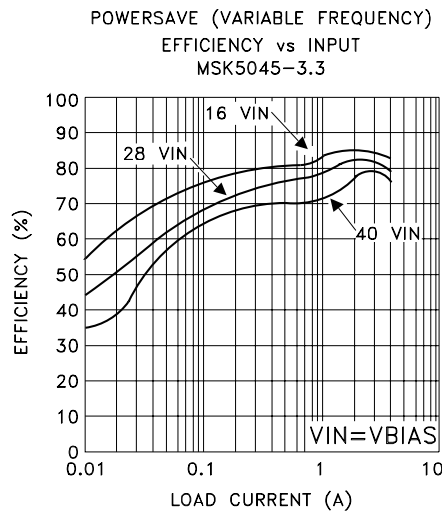
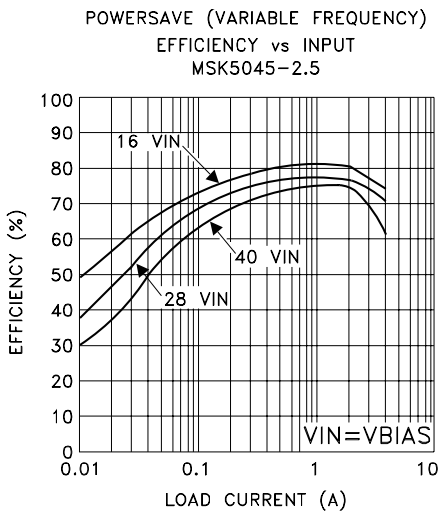
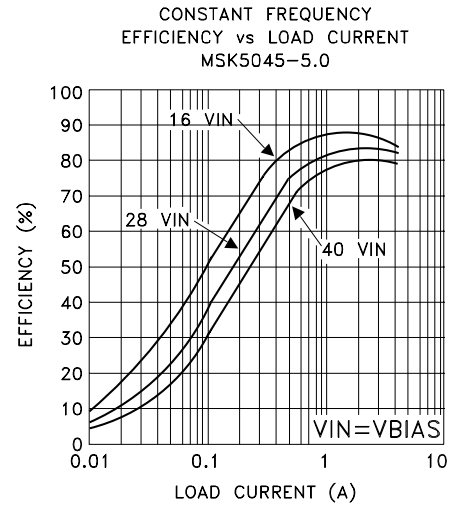
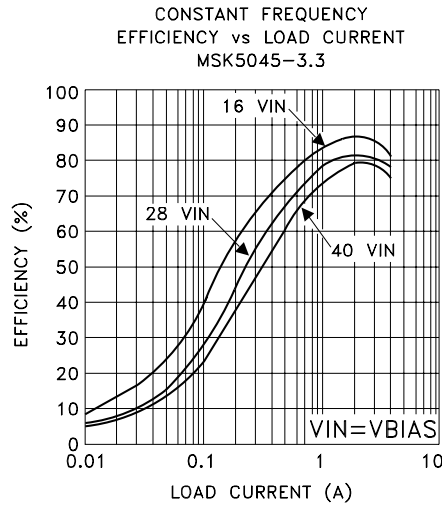
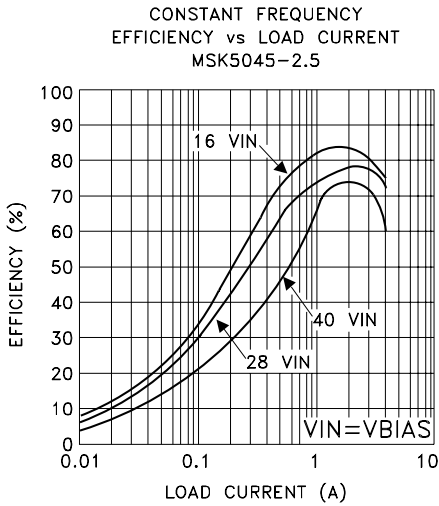
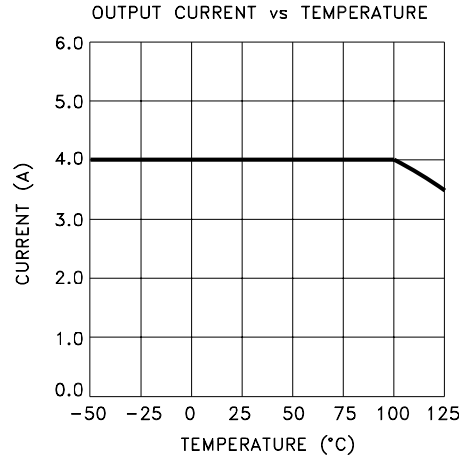
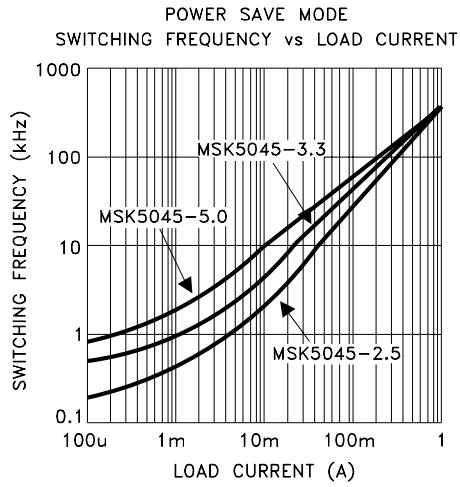

MECHANICAL SPECIFICATIONS

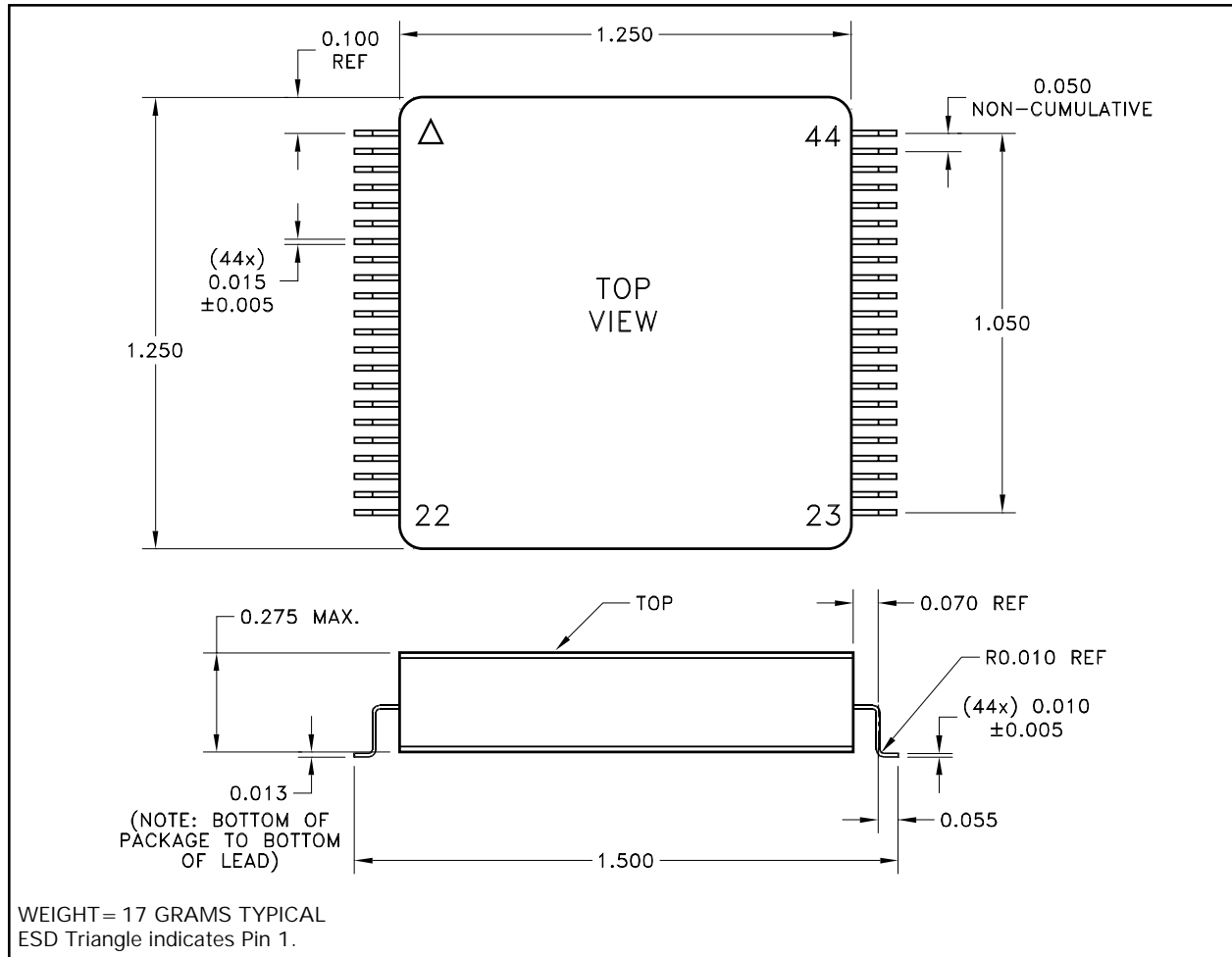

NOTE: ALL DIMENSIONS ARE ± 0.010 INCHES UNLESS OTHERWISE LABELED.

ORDERING INFORMATION

MSK5045-3.3 H G

LEAD FORM OPTIONS

BLANK = STRAIGHT; G = GULL WING

SCREENING

BLANK = INDUSTRIAL; E = EXTENDED RELIABILITY

H = MIL-PRF-38534 CLASS H

OUTPUT VOLTAGE

2.5 = +2.5V; 3.3 = +3.3V; 5.0 = +5.0V

GENERAL PART NUMBER

The above example is a +3.3V, Military regulator with gull wing leads.

MECHANICAL SPECIFICATIONS

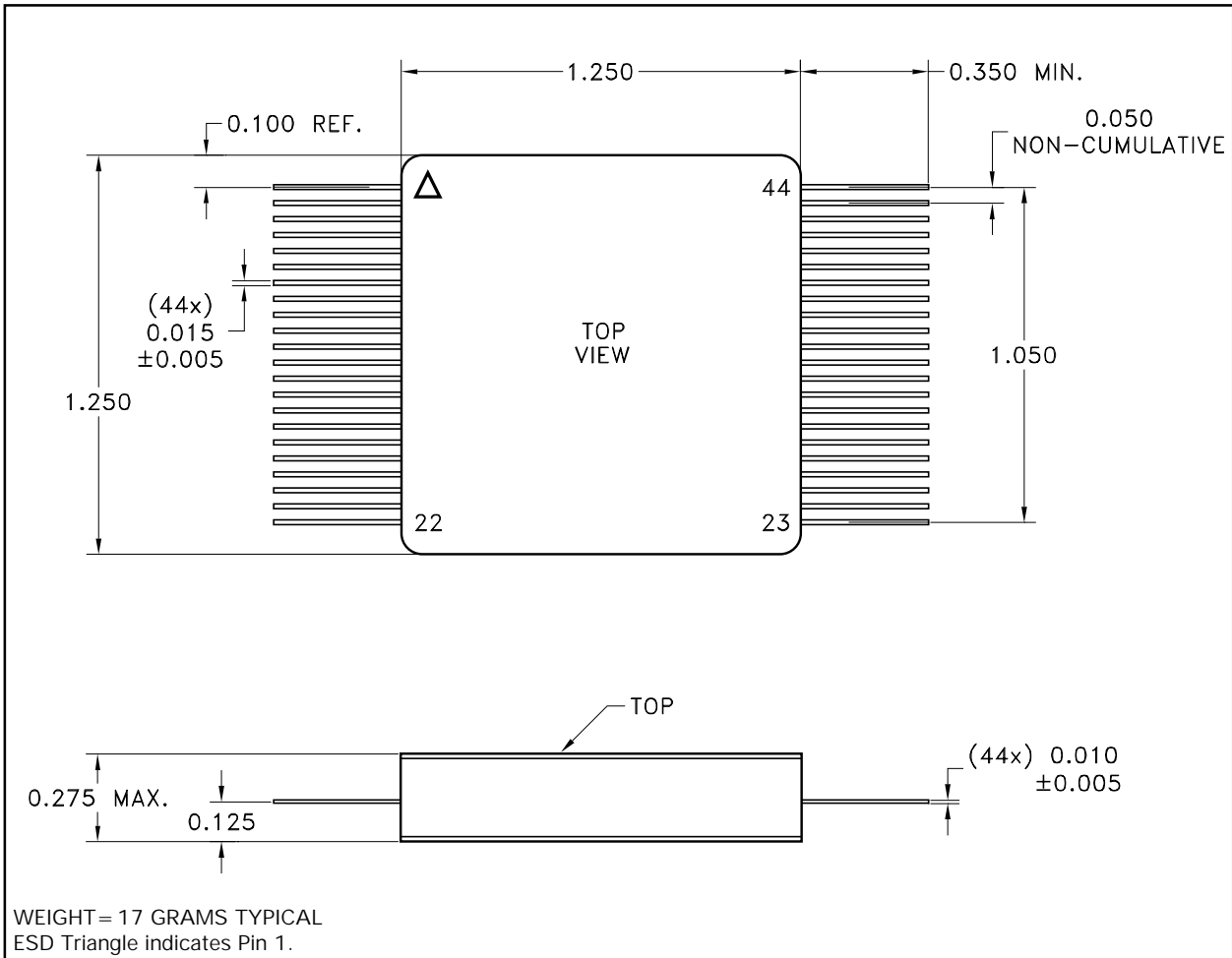

NOTE: ALL DIMENSIONS ARE ± 0.010 INCHES UNLESS OTHERWISE LABELED.

ORDERING INFORMATION

MSK5045-3.3 H

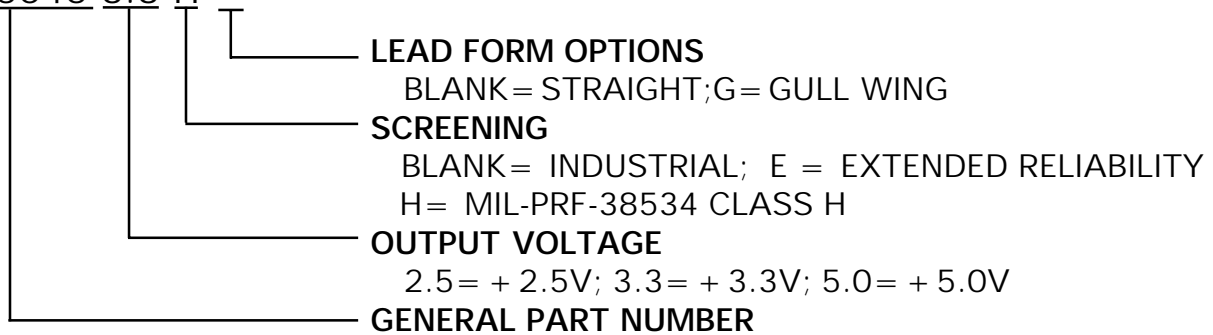

The above example is a + 3.3V, Military regulator.

M.S. Kennedy Corp.
4707 Dey Road, Liverpool, New York 13088
Phone (315) 701-6751
FAX (315) 701-6752
www.mskennedy.com

The information contained herein is believed to be accurate at the time of printing. MSK reserves the right to make changes to its products or specifications without notice, however, and assumes no liability for the use of its products. Please visit our website for the most recent revision of this datasheet.

Contact MSK for MIL-PRF-38534 qualification status.