



UC3666

Preliminary

CMOS IC

DUAL CHANNEL 800mA HIGH EFFICIENCY STEP-DOWN DC/DC CONVERTER

DESCRIPTION

The UTC **UC3666** is a dual channel high efficiency step-down DC/DC converter with constant frequency and current mode. A main switch and a synchronous rectifier for high efficiency are contained in each converter, and thus an external Schottky diode is saved. Supply current is only 300 μ A during normal operation and is reduced to less than 1 μ A in shutdown mode. The output voltage can be adjusted to as low as 0.6V. With input voltage range from 2.5V ~ 5.5V , each converter can deliver 800mA current to the load. Due to the internally fixed 1.8MHz switching frequency , small surface mount inductors and capacitors can be used. It can also run 100% duty cycle for low dropout applications.

The UTC **UC3666** is generally used in digital still cameras, portable instruments, slim-type DVD, microprocessors and DSP core supplies, wireless and DSL card, PDAs, smart phones, cellular telephones and so on.

FEATURES

- * high efficiency
- * Current mode operation
- * Low quiescent current less than 300 μ A (Active mode)
- * Input voltage varying from 2.5V to 5.5V
- * Output current on each channel: 800mA
- * Fixed frequency operation
- * 0 - 100% full duty ratio in dropout
- * 0.6V reference allows low output voltages
- * Over-temperature protection circuit
- * Shutdown current less than 0.1 μ A
- * RoHS Compliant (100% green available)
- * Halogen Free

ORDERING INFORMATION

Ordering Number		Package	Packing
Lead Free	Halogen Free	SON-10	Tape Reel
UC3666L-B10-R	UC3666G-B10-R		

Note: xx: Output Voltage, refer to Marking Information.

<p>UC3666L - B10 - R</p>	<p>(1) R: Tape Reel</p> <p>(2) B10: SON-10</p> <p>(3) G: Halogen Free, L: Lead Free</p>
--------------------------	---

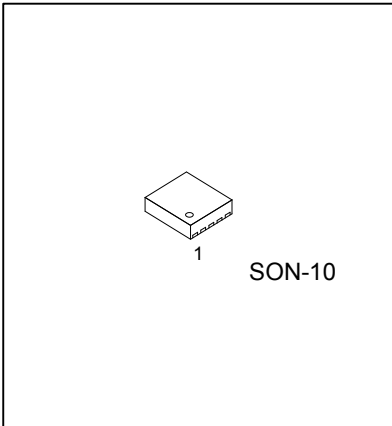

■ PIN CONFIGURATION

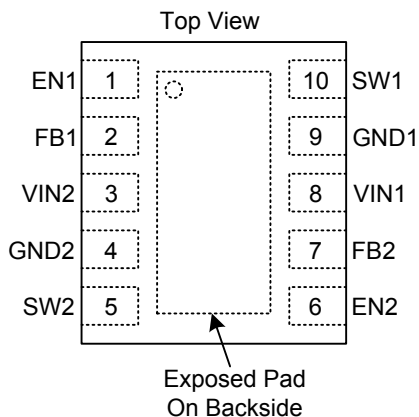

■ PIN DESCRIPTION

PIN NO.	PIN NAME	DESCRIPTION
1	EN1	Channel 1 Regulator Enable Control Input Pin. Drive EN1 above 1.5V to turn on channel1. Drive EN1 below 0.3V to turn it off (shutdown current < 0.1uA).
2	FB1	Channel 1 Voltage Feedback Pin
3	VIN2	Channel 2 Supply Pin
4	GND2	Channel 2 Ground Pin
5	SW2	Channel 2 Power Switch Output
6	EN2	Channel 2 Regulator Enable Control Input Pin. Drive EN2 above 1.5V to turn on channel2. Drive EN2 below 0.3V to turn it off (shutdown current < 0.1uA).
7	FB2	Channel 2 Voltage Feedback Pin
8	VIN1	Channel 1 Supply Pin
9	GND1	Channel 1 Ground Pin
10	SW1	Channel 1 Power Switch Output

■ BLOCK DIAGRAM

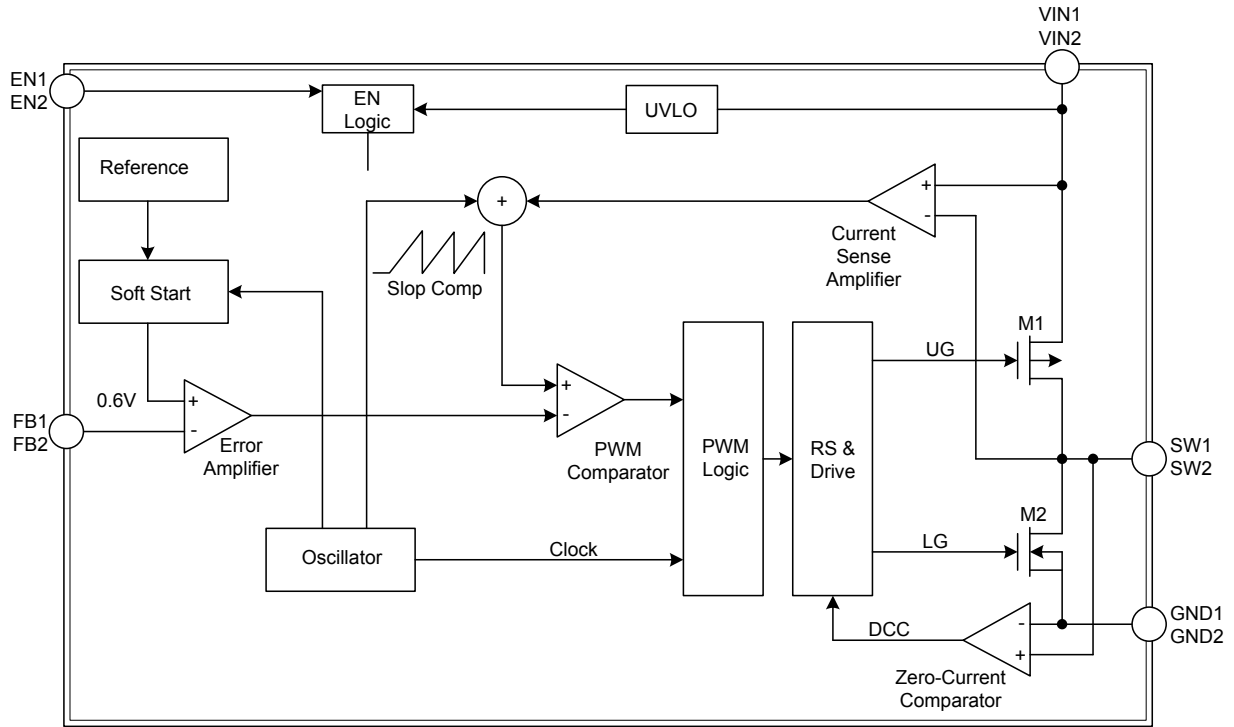

■ ABSOLUTE MAXIMUM RATING

PARAMETER	SYMBOL	RATINGS	UNIT
Input Supply Voltage	V_{IN}	GND-0.3 ~ +6.5	V
SW Voltage		-0.3 ~ $V_{IN}+0.3$	V
ENB, V_{FB} Voltage		-0.3 ~ V_{IN}	V
SW Peak Current		1.5	A
ESD Classification		Class 2	
Junction Temperature	T_J	125	°C
Operating Temperature	T_{orp}	-20 ~ +85	°C
Storage Temperature Range	T_{STG}	-65 ~ +150	°C

Note: Absolute maximum ratings are those values beyond which the device could be permanently damaged.

Absolute maximum ratings are stress ratings only and functional device operation is not implied.

The IC has a protection circuit against static electricity. Do not apply high static electricity or high voltage that exceeds the performance of the protection circuit to the IC.

■ THERMAL DATA

PARAMETER	SYMBOL	TYP	MAX	UNIT
Junction ambient	θ_{JA}		50	°C/W

■ ELECTRICAL CHARACTERISTICS (Recommended Operating Conditions, unless otherwise specified; $V_{IN}=3.6V$, $T_A=0 \sim 70^\circ C$ (typical= $25^\circ C$))

PARAMETER	SYMBOL	TEST CONDITIONS	MIN	TYP	MAX	UNIT
Supply Voltage	V_{IN}		2.5		5.5	V
Feedback Current	I_{VFB}		-30	0.5	30	nA
Regulated Feedback Voltage	V_{FB}	$T_A=25^\circ C$	0.588	0.6	0.612	V
		$-40^\circ C \leq T_A \leq 85^\circ C$	0.582	0.6	0.618	V
Reference Voltage Line Regulation	ΔV_{FB}	$V_{IN}=2.5V \sim 5.5V$		0.04	0.4	%V
Output Voltage Line Regulation	ΔV_{OUT}	$V_{IN}=2.5V \sim 5.5V$		0.04	0.4	%V
Output Voltage Load Regulation	$V_{LOADRGE}$			0.5		%
Shutdown Current	I_S	$V_{EN}=0V$, $V_{IN}=5.5V$		0.01	1	μA
SW Leakage Current	I_{LEAK}	$V_{EN}=0V$, $V_{IN}=5.5V$, $V_{SW}=0V$ or $5.5V$	-1		1	μA
PMOSFET On Resistance	R_{DSONP}	$I_{SW}=100mA$		0.35		Ω
NMOSFET On Resistance	R_{DSONN}	$I_{SW}=100mA$		0.24		Ω
PMOSFET Current Limit	I_{PCL}	Duty Cycle=100% Current Pulse Width<1ms	0.9	1.2	1.4	A
Oscillator Frequency	f_{OSC}		1.2	1.6	2.0	MHz
Thermal Shutdown Threshold	T_S			145		°C
EN High Level Input Voltage	V_{EN}	$-40^\circ C \leq T_A \leq +85^\circ C$	0.9			V
EN Low Level Input Voltage	V_{EN}	$-40^\circ C \leq T_A \leq +85^\circ C$			0.3	V
EN Input Current	I_{EN}	$V_{EN}=0V \sim V_{IN}$	-1		1	μA

■ TYPICAL APPLICATION CIRCUIT

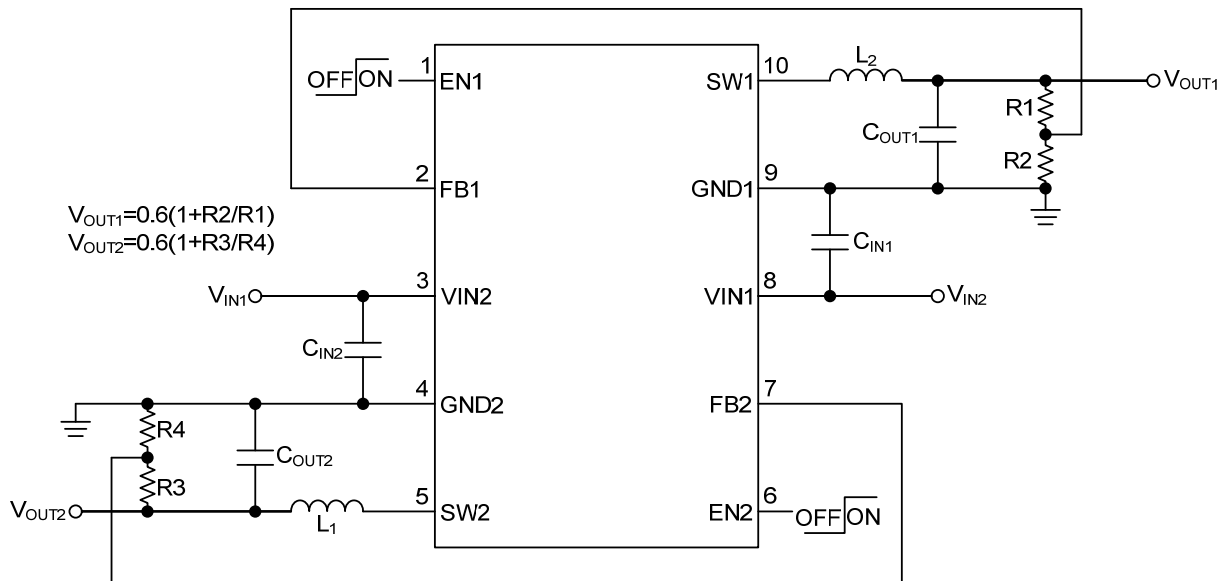

■ FUNCTION DESCRIPTION

The **UC3666** is a dual channel constant frequency current mode PWM step-down converter. It is designed for low voltage, Li-Ion battery powered applications requiring high efficiency and small size. The output voltage can be adjusted from 0.6V to 5.5V by means of an external resistor divider. A main switch and a synchronous rectifier are integrated to provide high efficiency, thus an external Schottky diode is saved. This device can achieve 100% duty cycle.

The duty cycle D of a step-down converter can be calculated as follows:

$$D = T_{ON} \times f_{OSC} \times 100\% = V_{OUT} / V_{IN} \times 100\%$$

(Where T_{ON} is the main switch on time and f_{OSC} is the oscillator frequency (1.6MHz)).

Current Mode PWM Control

Slope compensated current mode PWM control provides stable switching and cycle-by-cycle current limit for superior load and line response and protection of the internal main switch and synchronous rectifier.

The **UC3666** has a constant switching frequency of 1.6MHz and can adjust the output voltage. During each cycle, the PWM comparator modulates the power transferred to the load by changing the inductor peak current based on the feedback error voltage.

The main switch is switched on for a certain time to ramp the inductor current at each rising edge of the internal oscillator, and switched off when the peak inductor current exceeds the error voltage during normal operation.

When the main switch is turned off, the synchronous rectifier will be turned on as soon as possible, and then stay on until either the inductor current drops to zero or the next cycle starts. To get a high efficiency, the device is skipped pulses at light load.

Dropout Operation

The **UC3666** allows the main switch to keep for more than one switching cycle and increases the duty cycle while the input voltage decreases until nearly equal to the output voltage. When the duty cycle reaches 100%, the main switch is held on continuously to drive the output with current until it is equal to the P-MOSFET current limit. Thus, the output voltage can be calculated as the input voltage minus the voltage drop across the main switch and the inductor.

Short Circuit Protection

Short circuit protection is incorporated in **UC3666**. When the output is shorted to ground, the oscillator frequency is reduced to protect inductor current from being damaged due to it increasing beyond the P-MOSFET current limit.

In order to make the short circuit current lower, the P-MOSFET current limit is also reduced. The values of frequency and current limit are restored until the short circuit condition is removed as well as the feedback voltage reaches 0.6V.

Maximum Load Current

The **UC3666**'s input voltage can be of as low as 2.5V, however, at lower input voltage, the maximum load current decreases because of the large IR drop on the main switch and synchronous rectifier.

The slope compensation signal reduces the peak inductor current as a function of the duty cycle to prevent sub-harmonic oscillations as duty cycles become higher than 50%. Conversely the current limit increases as the duty cycle decreases match other diagrams in this datasheet.

Soft Start/Enable

Soft start limits the current surge seen at the input and eliminates output voltage overshoot. The enable pin is active high. When pulled low, the enable input (EN) forces the UTC UC3666 into a low-power, non-switching state. The total input current during shutdown is less than 1 μ A.

Over-temperature

Thermal protection completely disables switching when internal dissipation becomes excessive. The junction over-temperature threshold is 145 $^{\circ}$ C with 10 $^{\circ}$ C of hysteresis. Once an over-temperature condition is removed, the output voltage automatically recovers.

UTC assumes no responsibility for equipment failures that result from using products at values that exceed, even momentarily, rated values (such as maximum ratings, operating condition ranges, or other parameters) listed in products specifications of any and all UTC products described or contained herein. UTC products are not designed for use in life support appliances, devices or systems where malfunction of these products can be reasonably expected to result in personal injury. Reproduction in whole or in part is prohibited without the prior written consent of the copyright owner. The information presented in this document does not form part of any quotation or contract, is believed to be accurate and reliable and may be changed without notice.