

# 16 Mbit LPC Flash

## SST49LF160C



Advance Information

### FEATURES:

- **Organized as 2M x8**
- **Conforms to LPC Interface Specification**
  - Support Single-Byte LPC Memory Read/Write Cycles
- **Single 3.0-3.6V Read and Write Operations**
- **LPC Mode**
  - 5-signal LPC bus interface for both in-system and factory programming using programmer equipment
  - 33 MHz clock frequency operation
  - WP#/AAI and TBL# pins provide hardware Write protect for entire chip and/or top Boot Block
  - Block Locking Registers for individual block Read-Lock, Write-Lock, and Lock-Down protection
  - 5 GPI pins for system design flexibility
  - 4 ID pins for multi-chip selection
  - Status register for End-of-Write detection
  - Program-/Erase-Suspend Read or Write to other blocks during Program-/Erase-Suspend
- **Two-cycle Command Set**
- **Security ID Feature**
  - 256-bit Secure ID space
    - 64-bit Unique Factory Pre-programmed Device Identifier
    - 192-bit User-Programmable OTP
- **Superior Reliability**
  - Endurance: 100,000 Cycles (typical)
  - Greater than 100 years Data Retention
- **Low Power Consumption**
  - Active Read Current: 12 mA (typical)
  - Standby Current: 10  $\mu$ A (typical)
- **Uniform 4 KByte sectors**
  - 35 Overlay Blocks: one 16-KByte Boot Block, two 8-KByte Parameter Blocks, one 32-Kbyte Parameter Block, thirty-one 64-KByte Main Blocks.
- **Fast Sector-Erase/Program Operation**
  - Sector-Erase Time: 18 ms (typical)
  - Block-Erase Time: 18 ms (typical)
  - Program Time: 7  $\mu$ s (typical)
- **Auto Address Increment (AAI) for Rapid Factory Programming (High Voltage Enabled)**
  - RY/BY# pin for End-of-Write detection
  - Multi-Byte Program
  - Chip Rewrite Time: 4 seconds (typical)
- **Packages Available**
  - 32-lead PLCC
- **All non-Pb (lead-free) devices are RoHS compliant**

### PRODUCT DESCRIPTION

The SST49LF160C flash memory device is designed to interface with host controllers (chipsets) that support a low-pin-count (LPC) interface for system firmware applications. The SST49LF160C device complies with the LPC Interface Specification. The LPC interface operates with 5 signal pins versus 32 pins of a 8-bit parallel flash memory. This frees up pins on the ASIC host controller resulting in lower ASIC costs and a reduction in overall system costs due to simplified signal routing.

The SST49LF160C uses a 5-signal LPC interface to support both in-system and rapid factory programming using programmer equipment. A high voltage pin (WP#/AAI) is used to enable Auto Address Increment (AAI) mode. The SST49LF160C offers hardware block protection in addition to individual block protection via software registers for critical system code and data. A 256-bit Security ID space with a 64-bit factory pre-programmed unique number and a 192-

bit user programmable OTP area enhances the user's ability to use new security techniques and implement a new data protection scheme. The SST49LF160C also provides general purpose inputs (GPI) for system design flexibility.

The SST49LF160C flash memory device is manufactured with SST's proprietary, high-performance SuperFlash technology. The split-gate cell design and thick-oxide tunneling injector attain greater reliability and manufacturability compared with alternative technology approaches. The SST49LF160C device significantly improves performance and reliability, while lowering power consumption. The SST49LF160C device writes (Program or Erase) in-system with a single 3.0-3.6V power supply. It uses less energy during Erase and Program than alternative flash memory technologies.



Advance Information

The total energy consumed is a function of the applied voltage, current and time of application. Since for any given voltage range, the SuperFlash technology uses less current to program and has a shorter erase time, the total energy consumed during any Erase or Program operation is less than alternative flash memory technologies.

The SuperFlash technology provides fixed Erase and Program time, independent of the number of Erase/Program cycles that have performed. Therefore the system software or hardware does not have to be calibrated or correlated to the cumulative number of erase cycles as is necessary with alternative flash memory technologies, whose Erase and Program time increase with accumulated Erase/Program cycles. To protect against inadvertent write, the SST49LF160C device has on-chip hardware and software write protection schemes. It is offered with a typical endurance of 100,000 cycles. Data retention is rated at greater than 100 years.

The SST49LF160C product provides a maximum program time of 10 μs per byte with a single-byte Program operation; effectively 5 μs per byte with a dual-byte Program operation and 2.5 μs per byte with a quad-byte Program operation. End-of-Write can be detected by the RY/BY# pin output in AAI mode and by reading the software status register during an in-system Program or Erase operation.

The SST49LF160C is offered in a 32-PLCC lead-free package to address the growing need for non-Pb solutions in electronic components. Non-Pb package versions can be obtained by ordering products with a package code suffix of "E" as the environmental attribute in the product part number. See Figure 3 for pin assignments and Table 1 for pin descriptions.

TABLE OF CONTENTS

PRODUCT DESCRIPTION . . . . . 1
LIST OF FIGURES . . . . . 4
LIST OF TABLES . . . . . 5
FUNCTIONAL BLOCKS . . . . . 6
DEVICE MEMORY MAP . . . . . 7
PIN ASSIGNMENTS . . . . . 8
PIN DESCRIPTIONS . . . . . 9
Clock . . . . . 10
Input/Output Communications . . . . . 10
Input Communication Frame . . . . . 10
Reset . . . . . 10
Identification Inputs . . . . . 10
General Purpose Inputs . . . . . 10
Write Protect / Top Block Lock . . . . . 10
AAI Enable . . . . . 10
Ready/Busy . . . . . 10
Load Enable . . . . . 11
No Connection (NC) . . . . . 11
DESIGN CONSIDERATIONS . . . . . 11
MODE SELECTION . . . . . 11



# 16 Mbit LPC Flash SST49LF160C

Advance Information

LPC MODE .....	11
Device Operation .....	11
LPC MEMORY CYCLES .....	12
LPC Memory Read Cycle .....	12
LPC Memory Write Cycle .....	13
Abort Mechanism .....	14
Response to Invalid Fields for LPC Memory Cycle .....	14
Multiple Device Selection .....	15
DEVICE COMMANDS .....	16
Read-Array Command .....	17
Read-Software-ID Command .....	17
Read-Status-Register Command .....	17
Clear-Status-Register Command .....	17
Sector-/Block-Erase Command .....	18
Program Command .....	18
Program-/Erase-Suspend or Program-/Erase-Resume Operations .....	18
Erase-Suspend/ Erase-Resume Commands .....	18
Program-Suspend/ Program-Resume Command .....	19
Security ID Commands .....	19
REGISTERS .....	20
General Purpose Inputs Register .....	20
Block Locking Registers .....	20
Security ID Registers .....	22
JEDEC ID Registers .....	23
AUTO-ADDRESS INCREMENT (AAI) MODE .....	24
AAI Mode with Multi-Byte Programming .....	24
AAI Data Load Protocol .....	25
ELECTRICAL SPECIFICATIONS .....	26
DC Characteristics .....	27
AC Characteristics .....	30
PRODUCT ORDERING INFORMATION .....	34
PACKAGING DIAGRAMS .....	35



**LIST OF FIGURES**

FIGURE 1: Functional Block Diagram . . . . . 6  
FIGURE 2: Device Memory Map for SST49LF160C . . . . . 7  
FIGURE 3: Pin Assignments for 32-lead PLCC . . . . . 8  
FIGURE 4: LPC Memory Read Cycle Waveform . . . . . 12  
FIGURE 5: LPC Memory Write Cycle Waveform . . . . . 13  
FIGURE 6: Erase-Suspend Flow Chart . . . . . 19  
FIGURE 7: AAI Load Protocol Waveform. . . . . 25  
FIGURE 8: LCLK Waveform (LPC Mode) . . . . . 28  
FIGURE 9: Reset Timing Diagram (LPC MODE). . . . . 29  
FIGURE 10: Output Timing parameters (LPC Mode). . . . . 31  
FIGURE 11: Input Timing Parameters (LPC Mode) . . . . . 31  
FIGURE 12: Input Timing Parameters (AAI Mode) . . . . . 32  
FIGURE 13: AC Input/Output Reference Waveforms . . . . . 33  
FIGURE 14: A Test Load Example. . . . . 33  
FIGURE 15: 32-lead Plastic Lead Chip Carrier (PLCC) SST Package Code: NH . . . . . 35



## LIST OF TABLES

TABLE 1: Pin Description . . . . .	9
TABLE 2: Transfer Size Supported . . . . .	11
TABLE 3: LPC Memory Cycles START Field Definition . . . . .	11
TABLE 4: LPC Memory Read Cycle Field Definitions . . . . .	12
TABLE 5: LPC Memory Write Cycle Field Definitions . . . . .	13
TABLE 6: Boot Device Physical Addresses Decoding . . . . .	14
TABLE 7: LPC Memory Multiple Device Selection Configuration . . . . .	15
TABLE 8: Software Command Sequence . . . . .	16
TABLE 9: Product Identification . . . . .	17
TABLE 10: Software Status Register . . . . .	17
TABLE 11: Security ID Addresses . . . . .	19
TABLE 12: General Purpose Register . . . . .	20
TABLE 13: Block Locking Registers . . . . .	20
TABLE 14: Block Locking Register Bits . . . . .	21
TABLE 15: Security ID Registers . . . . .	22
TABLE 16: JEDEC ID Registers . . . . .	23
TABLE 17: LPC Memory Map Register Addresses . . . . .	23
TABLE 18: LD# Input and RY/BY# Status in AAI Mode . . . . .	24
TABLE 19: AAI Programming Cycle (initiated with WP#/AAI at V <sub>H</sub> ONLY) . . . . .	25
TABLE 20: DC Operating Characteristics (All Interfaces) . . . . .	27
TABLE 21: Recommended System Power-up Timings . . . . .	27
TABLE 22: Pin Capacitance . . . . .	27
TABLE 23: Reliability Characteristics . . . . .	28
TABLE 24: Clock Timing Parameters (LPC Mode) . . . . .	28
TABLE 25: Reset Timing Parameters, V <sub>DD</sub> =3.0-3.6V (LPC Mode) . . . . .	29
TABLE 26: Read/Write Cycle Timing Parameters, V <sub>DD</sub> =3.0-3.6V (LPC Mode) . . . . .	30
TABLE 27: AC Input/Output Specifications (LPC Mode) . . . . .	30
TABLE 28: Interface Measurement Condition Parameters (LPC Mode) . . . . .	31
TABLE 29: Input Cycle Timing Parameters, V <sub>DD</sub> =3.0-3.6V (AAI Mode) . . . . .	32
TABLE 30: Revision History . . . . .	35



Advance Information

## FUNCTIONAL BLOCKS

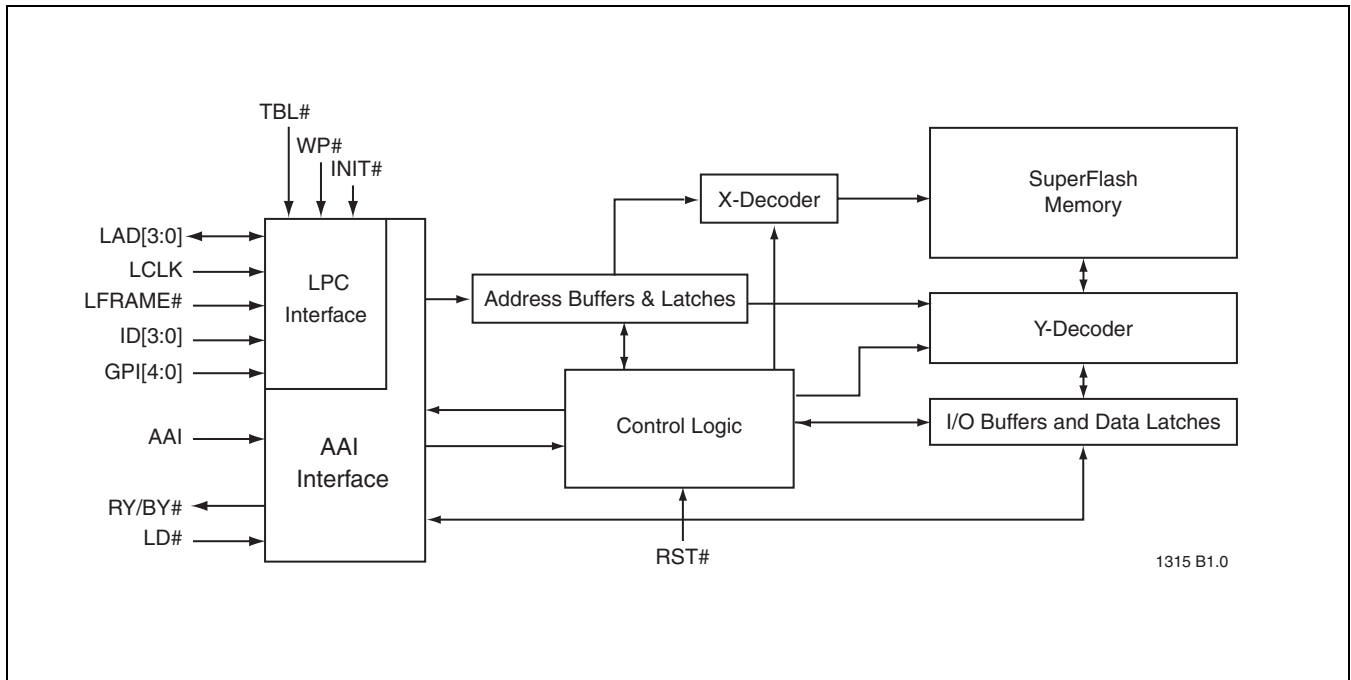

FIGURE 1: Functional Block Diagram

DEVICE MEMORY MAP

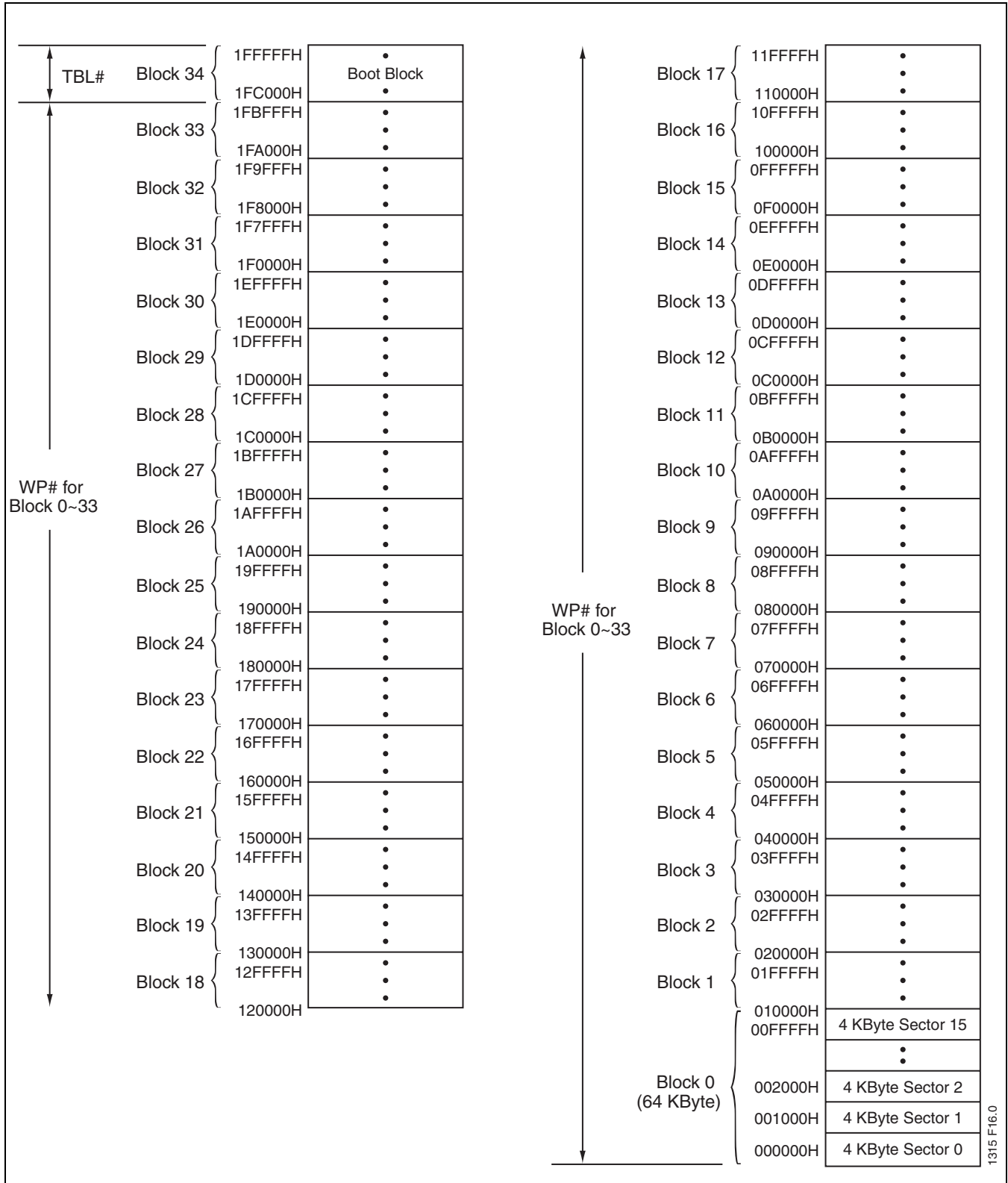
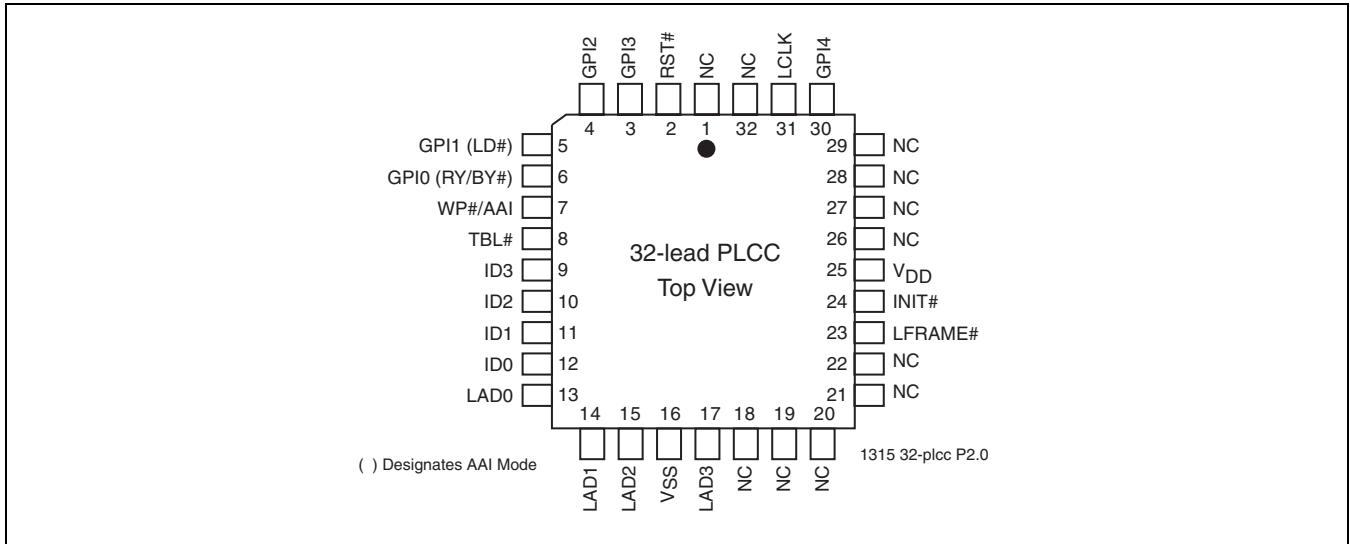

FIGURE 2: Device Memory Map for SST49LF160C



Advance Information

**PIN ASSIGNMENTS**



**FIGURE 3: Pin Assignments for 32-lead PLCC**



**PIN DESCRIPTIONS**

**TABLE 1: Pin Description**

Symbol	Pin Name	Type <sup>1</sup>	Interface		Functions
			AAI	LPC	
LCLK	Clock	I	X	X	To accept a clock input from the control unit
LAD[3:0]	Address and Data	I/O	X	X	To provide LPC bus information, such as addresses and command Inputs/Outputs data.
LFRAME#	Frame	I	X	X	To indicate the start of a data transfer operation; also used to abort an LPC cycle in progress.
RST#	Reset	I	X	X	To reset the operation of the device
INIT#	Initialize	I	X	X	This is the second reset pin for in-system use. This pin is internally combined with the RST# pin. If this pin or RST# pin is driven low, identical operation is exhibited.
ID[3:0]	Identification Inputs	I	X	X	These four pins are part of the mechanism that allows multiple parts to be attached to the same bus. The strapping of these pins is used to identify the component. The boot device must have ID[3:0]=0000, all subsequent devices should use sequential up-count strapping. These pins are internally pulled-down with a resistor between 20-100 K $\Omega$ .
GPI[4:0]	General Purpose Inputs	I		X	These individual inputs can be used for additional board flexibility. The state of these pins can be read through LPC registers. These inputs should be at their desired state before the start of the LPC clock cycle during which the read is attempted, and should remain in place until the end of the Read cycle. Unused GPI pins must not be floated. GPI[2:4] are ignored when in AAI mode.
TBL#	Top Block Lock	I		X	When low, prevents programming to the boot block sectors at top of device memory. When TBL# is high it disables hardware write protection for the top block sectors. This pin cannot be left unconnected. TBL# setting is ignored when in AAI mode.
WP#/AAI	Write Protect	I		X	When low, prevents programming to all but the highest addressable block (Boot Block). When WP# is high it disables hardware write protection for these blocks. This pin cannot be left unconnected.
WP#/AAI	AAI Enable	I	X		When set to the Supervoltage $V_H = 9V$ , configures the device to program multiple bytes in AAI mode. When brought to $V_{IL}/V_{IH}$ , returns device to LPC mode.
RY/BY#	Ready/Busy#	O	X		Open drain output that indicates the device is ready to accept data in an AAI mode, or that the internal cycle is complete. Used in conjunction with LD# pin to switch between these two flag states.
LD#	Load-Enable#	I	X		Input pin which when low, indicates the host is loading data in an AAI programming cycle. If LD# is high, the host signals the AAI interface that it is terminating a command. LD# low/high switches the RY/BY# output from a "buffer free" flag to a "programming complete" flag.
V <sub>DD</sub>	Power Supply	PWR	X	X	To provide power supply (3.0-3.6V)
V <sub>SS</sub>	Ground	PWR	X	X	Circuit ground (0V reference)
NC	No Connection		N/A	N/A	Unconnected pins.

1. I=Input, O=Output



## Advance Information

### Clock

The LCLK pin accepts a clock input from the host controller.

### Input/Output Communications

The LAD[3:0] pins are used to serially communicate cycle information such as cycle type, cycle direction, ID selection, address, data, and sync fields.

### Input Communication Frame

The LFRAME# pin is used to indicate start of a LPC bus cycle. The pin is also used to abort an LPC bus cycle in progress.

### Reset

A  $V_{IL}$  on INIT# or RST# pin initiates a device reset. INIT# and RST# pins have the same function internally. It is required to drive INIT# or RST# pins low during a system reset to ensure proper CPU initialization. During a Read operation, driving INIT# or RST# pins low deselects the device and places the output drivers, LAD[3:0], in a high impedance state. The reset signal must be held low for a minimum of time  $T_{RSTP}$ . A reset latency occurs if a reset procedure is performed during a Program or Erase operation. See Table 25, Reset Timing Parameters, for more information. A device reset during an active Program or Erase operation will abort the operation and memory contents may become invalid due to data being altered or corrupted from an incomplete Erase or Program operation.

### Identification Inputs

These pins are part of a mechanism that allows multiple devices to be attached to the same bus. The strapping of these pins is used to identify the component. The boot device must have ID[3:0] = 0; all subsequent devices should use sequential count-up strapping. These pins are internally pulled-down with a resistor between 20-100 K $\Omega$ .

### General Purpose Inputs

The General Purpose Inputs (GPI[4:0]) can be used as digital inputs for the CPU to read. The GPI register holds the values on these pins. The data on the GPI pins must be stable before the start of a GPI register Read and remain stable until the Read cycle is complete. The pins must be driven low,  $V_{IL}$ , or high,  $V_{IH}$  but not left unconnected (float).

In the Auto Address Increment (AAI) mode, GPIO is used as Ready/Busy (RY/BY#), and GPI1 is used as Load Enable (LD#).

### Write Protect / Top Block Lock

The Top Boot Lock (TBL#) and Write Protect (WP#/AAI) pins are provided for hardware write protection of device memory in the SST49LF160C. The TBL# pin is used to write protect 16 KByte at the highest memory address range for the SST49LF160C. WP#/AAI pin write protects the remaining sectors in the flash memory. An active low signal at the TBL# pin prevents Program and Erase operations of the top Boot Block. When TBL# pin is held high, write protection of the top Boot Block is then determined by the Boot Block Locking registers. The WP#/AAI pin serves the same function for the remaining sectors of the device memory. The TBL# and WP#/AAI pins write protection functions operate independently of one another. Both TBL# and WP#/AAI pins must be set to their required protection states prior to starting a Program or Erase operation. A logic level change occurring at the TBL# or WP#/AAI pin during a Program or Erase operation could cause unpredictable results. TBL# and WP#/AAI pins cannot be left unconnected.

TBL# is internally OR'ed with the top Boot Block Locking register. When TBL# is low, the top Boot Block is hardware write protected regardless of the state of the Write-Lock bit for the Boot Block Locking register. Clearing the Write-Protect bit in the register when TBL# is low will have no functional effect, even though the register may indicate that the block is no longer locked.

WP#/AAI is internally OR'ed with the Block Locking register. When WP#/AAI is low, the blocks are hardware write protected regardless of the state of the Write-Lock bit for the corresponding Block Locking registers. Clearing the Write-Protect bit in any register when WP#/AAI is low will have no functional effect, even though the register may indicate that the block is no longer locked.

### AAI Enable

The AAI Enable pin (WP#/AAI) is used to enable the Auto Address Increment (AAI) mode. When the WP#/AAI pin is set to the Supervoltage  $V_H$  ( $9\pm 0.5V$ ), the device is in AAI mode with Multi-Byte programming. When the WP#/AAI pin is brought to  $V_{IL}/V_{IH}$  levels, the device returns to LPC mode.

### Ready/Busy

The Ready/Busy pin (RY/BY#), is an open drain output which indicates either the device is ready to accept data in AAI mode, or that the internal programming cycle is complete. The pin is used in conjunction with the LD# pin to switch between these two flag states (see Table 18).



# 16 Mbit LPC Flash SST49LF160C

Advance Information

## Load Enable

The Load Enable pin (LD#), is an input pin which when low, indicates the host is loading data in an AAI programming cycle. Data is loaded in the SST49LF160C at the rising edge of the clock. If LD# is high, it signals the AAI interface that the host is terminating the command. LD# low/high switches the RY/BY# output from buffer free flag to programming complete flag (see Table 18).

## No Connection (NC)

These pins are not connected internally.

## DESIGN CONSIDERATIONS

SST recommends a high frequency 0.1  $\mu$ F ceramic capacitor to be placed as close as possible between  $V_{DD}$  and  $V_{SS}$  less than 1 cm away from the  $V_{DD}$  pin of the device. Additionally, a low frequency 4.7  $\mu$ F electrolytic capacitor from  $V_{DD}$  to  $V_{SS}$  should be placed within 1 cm of the  $V_{DD}$  pin. If you use a socket for programming purposes add an additional 1-10  $\mu$ F next to each socket.

The RST# pin must remain stable at  $V_{IH}$  for the entire duration of an Erase operation. WP#/AAI must remain stable at  $V_{IH}$  for the entire duration of the Erase and Program operations for non-Boot Block sectors. To write data to the top Boot Block sectors, the TBL# pin must also remain stable at  $V_{IH}$  for the entire duration of the Erase and Program operations.

## MODE SELECTION

The SST49LF160C flash memory device operates in two distinct interface modes: the LPC mode and the Auto Address Increment (AAI) mode. The WP#/AAI pin is used to set the interface mode selection. The device is in AAI mode when the WP#/AAI pin is set to the Supervoltage  $V_H$  ( $9\pm 0.5V$ ), and in the LPC mode when the WP#/AAI is set to  $V_{IL}/V_{IH}$ . The mode selection must be configured prior to device operation.

## LPC MODE

### Device Operation

The SST49LF160C supports Single-Byte LPC Memory Read and Write cycle types as defined in Low Pin Count Interface Specification. Table 2 shows the size of transfer supported by the SST49LF160C.

TABLE 2: Transfer Size Supported

Cycle Type	Size of Transfer
LPC Memory Read	1 Byte
LPC Memory Write	1 Byte

T2.0 1315

The LPC mode uses a 5-signal communication interface: one control line, LFRAME#, which is driven by the host to start or abort a bus cycle, a 4-bit data bus, LAD[3:0], used to communicate cycle type, cycle direction, ID selection, address, data and sync fields. The device enters standby mode when LFRAME# is taken high and no internal operation is in progress.

The host drives LFRAME# signal from low-to-high to capture the start field of a LPC cycle. On the cycle in which LFRAME# goes inactive, the last latched value is taken as the START value. The START value determines whether the SST49LF160C will respond to a LPC Memory Read/Write cycle type as defined in Table 3.

TABLE 3: LPC Memory Cycles START Field Definition

START Value	Definition
0000	Start of an LPC memory cycle. The direction (Read or Write) is determined by the second field of the LPC cycle.

T3.1 1315

See following sections on details of LPC Memory cycle types (Tables 4 and 5). Two-cycle Program and Erase command sequences are used to initiate LPC Memory Program and Erase operations. See Table 8 for a listing of Program and Erase commands.



Advance Information

## LPC MEMORY CYCLES

### LPC Memory Read Cycle

TABLE 4: LPC MEMORY READ CYCLE FIELD DEFINITIONS

Clock Cycle	Field Name	Field Contents LAD[3:0] <sup>1</sup>	LAD[3:0] Direction	Comments
1	START	0000	IN	LFRAME# must be active (low) for the device to respond. Only the last field latched before LFRAME# transitions high will be recognized. The START field contents (0000b) indicate an LPC Memory cycle.
2	CYCTYPE + DIR	010X	IN	Indicates the type of LPC Memory cycle. Bits 3:2 must be "01b" for memory cycle. Bit 1 indicates the type of transfer "0" for Read. Bit 0 is reserved.
3-10	ADDR	YYYY	IN	Address Phase for Memory Cycle. LPC protocol supports a 32-bit address phase. YYYY is one nibble of the entire address. Addresses are transferred most-significant nibble first. The SST49LF160C encodes ID and register space access in the address fields.
11	TAR0	1111	IN then Float	In this clock cycle, the host drives the bus to all 1s and then floats the bus. This is the first part of the bus "turnaround cycle."
12	TAR1	1111 (float)	Float then OUT	The SST49LF160C takes control of the bus during this cycle.
13	RSYNC	0000	OUT	The SST49LF160C outputs the value 0000b indicating that it has received data.
14	DATA	ZZZZ	OUT	ZZZZ is the least-significant nibble of the data byte.
15	DATA	ZZZZ	OUT	ZZZZ is the most-significant nibble of the data byte.
16	TAR0	1111	OUT, then Float	In this clock cycle, the SST49LF160C drives the bus to all 1s and then floats the bus. This is the first part of the bus "turn-around cycle."
17	TAR1	1111 (float)	Float, then IN	The host takes control of the bus during this cycle.

T4.0 1315

1. Field contents are valid on the rising edge of the present clock cycle.

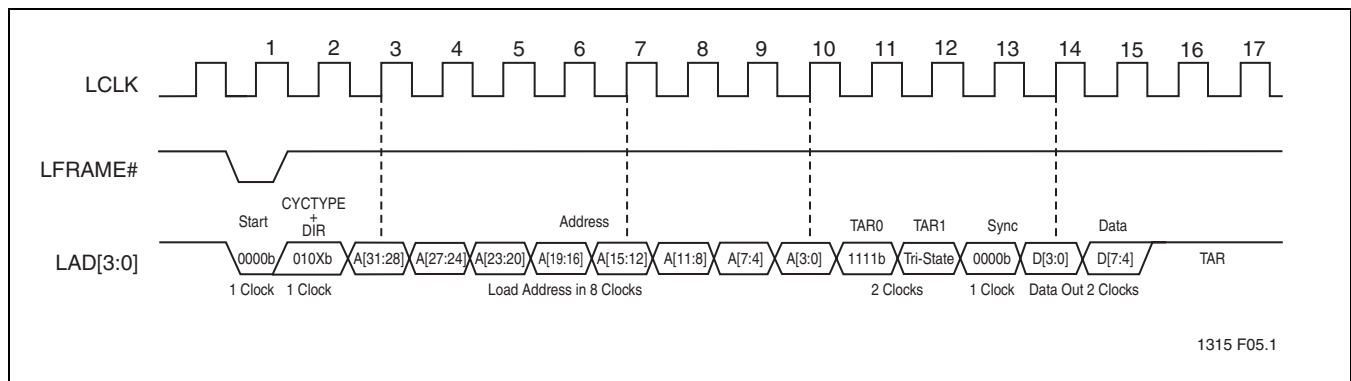

FIGURE 4: LPC MEMORY READ CYCLE WAVEFORM

## LPC Memory Write Cycle

TABLE 5: LPC MEMORY WRITE CYCLE FIELD DEFINITIONS

Clock Cycle	Field Name	Field Contents LAD[3:0] <sup>1</sup>	LAD[3:0] Direction	Comments
1	START	0000	IN	LFRAME# must be active (low) for the part to respond. Only the last start field latched before LFRAME# transitional high will be recognized. The START field contents (0000b) indicate an LPC Memory cycle.
2	CYCTYPE+ DIR	011X	IN	Indicates the type of LPC Memory cycle. Bits 3:2 must be "01b" for memory cycle. Bit 1 indicates the type of transfer "1" for Write. Bit 0 is reserved.
3-10	ADDR	YYYY	IN	Address Phase for Memory Cycle. LPC protocol supports a 32-bit address phase. YYYY is one nibble of the entire address. Addresses are transferred most-significant nibble first. The SST49LF160C encodes ID and register space access in the address fields.
11	DATA	ZZZZ	IN	ZZZZ is the least-significant nibble of the data byte.
12	DATA	ZZZZ	IN	ZZZZ is the most-significant nibble of the data byte.
13	TAR0	1111	IN then Float	In this clock cycle, the host has driven the bus to all 1s and then floats the bus. This is the first part of the bus "turnaround cycle."
14	TAR1	1111 (float)	Float then OUT	The SST49LF160C takes control of the bus during this cycle.
15	RSYNC	0000	OUT	The SST49LF160C outputs the value 0000b indicating that it has received data or a flash command.
16	TAR0	1111	OUT, then float	In this clock cycle, the SST49LF160C drives the bus to all 1s and then floats the bus. This is the first part of the bus "turn-around cycle."
17	TAR1	1111 (float)	Float, then IN	The host resumes control of the bus during this cycle.

T5.0 1315

1. Field contents are valid on the rising edge of the present clock cycle.

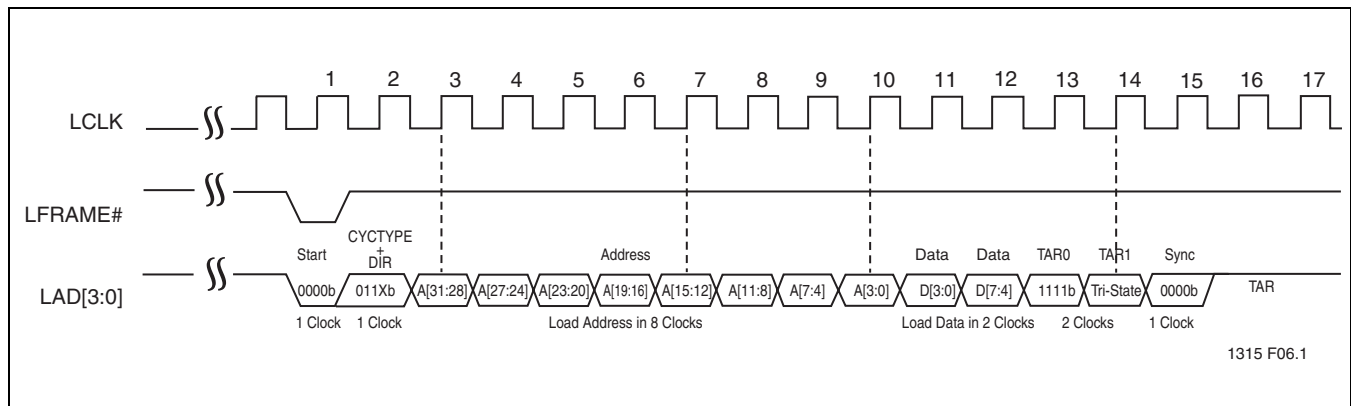

FIGURE 5: LPC MEMORY WRITE CYCLE WAVEFORM



Advance Information

**Abort Mechanism**

If LFRAME# is driven low for one or more clock cycles after the start of a bus cycle, the cycle will be terminated. The host may drive the LAD[3:0] with '1111b' (ABORT nibble) to return the interface to ready mode. The ABORT only affects the current bus cycle. For a multi-cycle command sequence, such as the Erase or Program commands, ABORT doesn't interrupt the entire command sequence, only the current bus cycle of the command sequence. The host can re-send the bus cycle for the aborted command and continue the command sequence after the device is ready again.

Once valid START, CYCTYPE + DIR, and address range (including ID bits) are received, the SST49LF160C will always complete the bus cycle. However, if the device is busy performing a flash Erase or Program operation, no new internal memory Write will be executed. As long as the states of LAD[3:0] and LFRAME# are known, the response of the SST49LF160C to signals received during the LPC cycle is predictable.

**Response to Invalid Fields for LPC Memory Cycle**

During an on-going LPC bus cycle, the SST49LF160C will not explicitly indicate that it has received invalid field sequences. The response to specific invalid fields or sequences is described as follows:

**ID mismatch:** ID information is included in the address bits of every LPC Memory cycle. Address bits [A<sub>25</sub>:A<sub>23</sub>, A<sub>21</sub>] are used to select the device with proper IDs. The SST49LF160C will compare the ID bits in the address field with ID[3:0]. If the ID bits in the address do not correspond to the hardware ID pins the device will ignore the cycle. See Device Commands section for details.

**Address out of range:** The address sequence is 8 fields long (32 bits). The address bits [A<sub>25</sub>:A<sub>23</sub>, A<sub>21</sub>] for the SST49LF160C are used to select the device with proper IDs. Unused most significant address bits must be set to "1" during LPC protocol transfer. Address A<sub>22</sub> has the special function of directing Read and Write operations to the flash core (A<sub>22</sub>=1) or to the register space (A<sub>22</sub>=0).

For the Boot Device (ID[3:0]=0000b), the SST49LF160C decodes the physical addresses of the Top 128 KByte Blocks (including Boot Block) at both system memory ranges indicated in Table 6.

**TABLE 6: BOOT DEVICE  
PHYSICAL ADDRESSES DECODING**

Memory Range	Also mapped at Memory Range
FFFF FFFFH - FFFE 0000H	000F FFFFH - 000E 0000H



## 16 Mbit LPC Flash SST49LF160C

Advance Information

### Multiple Device Selection

Multiple LPC flash devices may be strapped to increase memory densities in a system. The four ID pins, ID[3:0], allow up to 16 devices to be attached to the same bus by using different ID strapping in a system. BIOS support, bus loading, or the attaching bridge may limit this number. The boot device must have an ID of 0000b (determined by ID[3:0]); subsequent devices use incremental numbering. Equal density must be used with multiple devices.

### Multiple Device Selection for LPC Memory Cycle

For LPC Memory Read/Write cycles, ID information is included in the address bits of every cycle. The ID bits in the address field are inverse of the hardware strapping. The address bits [A<sub>25</sub>:A<sub>23</sub>, A<sub>21</sub>] are used to select the device with proper IDs. See Table 7 for device selection configurations. The SST49LF160C will compare these bits with ID[3:0]'s strapping values. If there is a mismatch, the device will ignore the remainder of the cycle.

**TABLE 7: LPC MEMORY MULTIPLE DEVICE  
SELECTION CONFIGURATION**

Device #	Hardware Strapping	ID Address Bits
	ID[3:0]	A <sub>25</sub> :A <sub>23</sub> , A <sub>21</sub>
0 (Boot device)	0000	1111
1	0001	1110
2	0010	1101
3	0011	1100
4	0100	1011
5	0101	1010
6	0110	1001
7	0111	1000
8	1000	0111
9	1001	0110
10	1010	0101
11	1011	0100
12	1100	0011
13	1101	0010
14	1110	0001
15	1111	0000

T7.0 1315



Advance Information

**DEVICE COMMANDS**

Device operation is controlled by commands written to the Command User Interface (CUI). Execution of a specific command is handled by internal functions after a CUI receives and processes the command. After power-up or a

Reset operation the device enters Read mode. Commands consist of one or two sequential Bus-Write operations. The commands are summarized in Table 8, "Software Command Sequence".

**TABLE 8: Software Command Sequence**

Command	Bus Cycles Required	First Bus Cycle			Second Bus Cycle		
		Oper	Addr <sup>1</sup>	Data	Oper	Addr <sup>1</sup>	Data
Read-Array/Reset	1	Write	X	FFH			
Read-Software-ID <sup>2</sup> / Read-Security-ID <sup>3</sup>	≥ 2	Write	X	90H	Read	IA <sup>4</sup>	ID <sup>5</sup>
Read-Status-Register <sup>3</sup>	2	Write	X	70H	Read	X	SRD <sup>6</sup>
Clear-Status-Register	1	Write	X	50H			
Sector-Erase <sup>7</sup>	2	Write	X	30H	Write	SAx <sup>8</sup>	D0H
Block-Erase <sup>7</sup>	2	Write	X	20H	Write	BAx	D0H
Program <sup>7,9</sup>	2	Write	X	40H or 10H	Write	WA <sup>10</sup>	WD <sup>11</sup>
Program-/Erase-Suspend	1	Write	X	B0H			
Program-/Erase-Resume	1	Write	X	D0H			
User-Security-ID-Program <sup>12</sup>	2	Write	X	A5H	Write	WA <sup>10</sup>	Data
User-Security-ID-Program-Lockout	2	Write	X	85H	Write	X	00H

T8.0 1315

1. This value must be a valid address within the device Memory Address Space. X can be V<sub>IH</sub> or V<sub>IL</sub>, but no other value.
2. SST Manufacturer's ID = BFH, is read with A<sub>20</sub>-A<sub>0</sub> = 0.  
SST49LF160C Device ID = 4CH, is read with A<sub>20</sub>-A<sub>1</sub> = 0, A<sub>0</sub> = 1.  
Following the Read-Software-ID/Read-Security-ID command,  
Read operations access Manufacturer's ID and Device ID or Security ID.
3. Following the Read-Software-ID/Read-Security-ID command, Read operations access manufacturer's ID and Device ID or Security ID. Read-Software-ID/Read-Security-ID and Read-Status-Register will return register data until another valid command is written.
4. IA = Device Identification Address/Security ID Address.
5. ID = Data read from identifier codes/Data read from Security ID
6. SRD = Data read from Status register
7. The sector or block must not be write-locked when attempting Erase or Program operations.  
Attempts to issue an Erase or Program command to a write-locked sector/block will fail.
8. SA<sub>x</sub> for Sector-Erase Address  
BA<sub>x</sub> for Block-Erase Address
9. The Program command operates on one byte at a time.
10. WA = Address of memory location to be written
11. WD = Data to be written at location WA
12. Valid addresses for the User Security ID space are from FFFC 0188H to FFFC 019FH.





# 16 Mbit LPC Flash SST49LF160C

Advance Information

## Read-Array Command

Upon initial device power-up and after exit from reset, the device defaults to the read array mode. This operation can also be initiated by writing the Read-Array command. (See Table 8.) The device remains available for array reads until another command is written. Once an internal Program/Erase operation starts, the device will not recognize the Read-Array command until the operation is completed, unless the operation is suspended via a Program/Erase Suspend command.

## Read-Software-ID Command

The Read-Software-ID operation is initiated by writing the Read-Software-ID command. Following the command, the device will output the manufacturer's ID and device ID from the addresses shown in Table 9. Any other valid command will terminate the Read-Software-ID operation.

The Read-Software-ID command is the same as the Read-Security-ID command. See "Security ID Commands" on page 19.

**TABLE 9: Product Identification**

	Address <sup>1</sup>	Data
Manufacturer's ID	FFFC 0000H	BFH
Device ID SST49LF160C	FFFC 0001H	4CH

T9.1 1315

1. Address shown in this column is for boot device only. Address locations should appear elsewhere in the 4 GByte system memory map depending on ID strapping values on ID[3:0] pins when multiple LPC memory devices are used in a system.

## Read-Status-Register Command

The Status register may be read to determine when a Sector-/Block-Erase or Program completes, and whether the operation completed successfully. The Status register may be read at any time by writing the Read-Status-Register command. After writing this command, all subsequent Read operations will return data from the Status register until another valid command is written.

The default value of the Status register after device power-up or reset is 80H.

## Clear-Status-Register Command

The user can reset the Status register's Block Protect Status (BPS) bit to 0 by issuing a Clear-Status-Register command. Device power-up and hardware reset will also reset BPS to 0.

**TABLE 10: Software Status Register**

Bit	Name	Function
0	RES	Reserved for future use
1	BPS	Block Protect Status The Block Write-Lock bit should be interrogated only after Erase or Program command is issued. It informs the system whether or not the selected block is locked. BPS does not provide a continuous indication of Write-Lock bit value. 0: Block Unlocked 1: Operation Aborted, Block Write-Lock bit set.
2:5	RES	Reserved for future use
6	ESS	Erase Suspend Status 0: Erase in progress/completed 1: Erase suspended
7	WSMS	Write State Machine Status Check WSMS to determine erase or program completion. 0: Busy 1: Ready

T10.0 1315



## Advance Information

### Sector-/Block-Erase Command

The Erase Command operates on one sector or block at a time. This command requires an (arbitrary) address within the sector or block to be erased. Note that a Sector/Block Erase operation changes all Sector/Block byte data to FFh. If a Read operation is performed after issuing the erase command, the device will automatically output Status Register data. The system can poll the Status Register in order to verify the completion of the Sector/Block Erase operation (please refer to Table 10, Status Register Definition). If a Sector/Block Erase is attempted on a locked block, the operation will fail and the data in the Sector/Block will not be changed. In this case, the Status Register will report the error (BPS=1).

### Program Command

The Program command operates on one byte at a time (Refer to Table 5). This command specifies the address and data to be programmed. During the Program operation the device automatically outputs the Status Register data when read. The system can poll the Status Register in order to verify the completion of the Program operation (refer to Table 10, "Software Status Register"). If a Program operation is attempted on a locked block, the operation will fail and the data in the addressed byte will not be changed. In this case, the Status Register will report the error (BPS=1).

### Program-/Erase-Suspend or Program-/Erase-Resume Operations

The Program-Suspend and Erase-Suspend operations share the same software command sequence (B0H). The Program-Resume and Erase-Resume operations share the same software command sequence (D0H). See Table 8, "Software Command Sequence" on page 16.

### Erase-Suspend/ Erase-Resume Commands

The Erase Suspend command allows Sector-Erase or Block-Erase interruption in order to read or program data in another block of memory. Once the Erase-Suspend command is executed, the device will suspend any on-going Erase operation within time  $T_{ES}$  (10  $\mu$ s). The device outputs status register data when read after the Erase-Suspend command is written. The system is able to determine when the Erase operation has been completed (WSMS=1) by polling the status register. After an Erase-Suspend, the device will set the status register ESS bit (ESS=1) if the Erase has been successfully suspended (refer to Table 10, "Software Status Register"). The Erase-Resume command resumes the Erase operation that had been previously suspended.

After a successful Erase-Suspend, a Read-Array command may be written to read data from a Sector/Block other than the suspended Sector/Block. A Program command sequence may also be issued during Erase Suspend to program data in memory locations other than the Sector/Block currently in the Erase-Suspend mode. If a Read-Array command is written to an address within the suspended Sector/Block this may result in reading invalid data. If a Program command is written to an address within the suspended Sector/Block the command is acknowledged but rejected. Other valid commands while erase is suspended include Read-Status-Register, Read-Device-ID, and Erase-Resume.

The Erase-Resume command resumes the Erase process in the suspended sector or block. After the Erase-Resume command is written, the device will continue the Erase process. Erase cannot resume until any Program operation initiated during Erase-Suspend has completed. Suspended operations cannot be nested: the system needs to complete or resume any previously suspended operation before a new operation can be suspended. See Figure 6 for flowchart.

### Program-Suspend/ Program-Resume Command

The Program-Suspend and Program-Resume commands have no influence on the device. Since the device requires a maximum of  $T_{BP}$  (10  $\mu$ s) in order to program a byte (see Table 26), when a Program-Suspend command is written, the suspended Byte Program operation will always be successfully completed within the suspend latency time ( $T_{ES} = T_{BP} = 10 \mu$ s).

### Security ID Commands

The SST49LF160C device offers a 256-bit Security ID space. The Security ID space is divided into two parts. One 64-bit segment is programmed at SST with a unique 64-bit number: this number cannot be changed by the user. The other segment is 192-bit wide and is left blank: this space is available for customers and can be programmed as desired.

The User-Security-ID-Program command is shown in Table 8, "Software Command Sequence". Use the memory addresses specified in Table 11 for Security ID programming. Once the customer segment is programmed, it can be locked to prevent any alteration. The User-Security-ID-Program-Lockout command is shown in Table 8, "Software Command Sequence".

In order to read the Security ID information, the user can issue a Read Security ID Command (90H) to the device. At this point the device enters the Read-Software-ID/Read-Security-ID mode. The Security ID information can be read at the memory addresses in Table 11.

A Read-Array/Reset command (FFH) must then be issued to the device in order to exit the Read-Software-ID/Read-Security-ID mode and return to Read-Array mode.

An alternate method to read the Security ID information is to read the Security ID registers located into the register space as described in the "Security ID Registers" section.

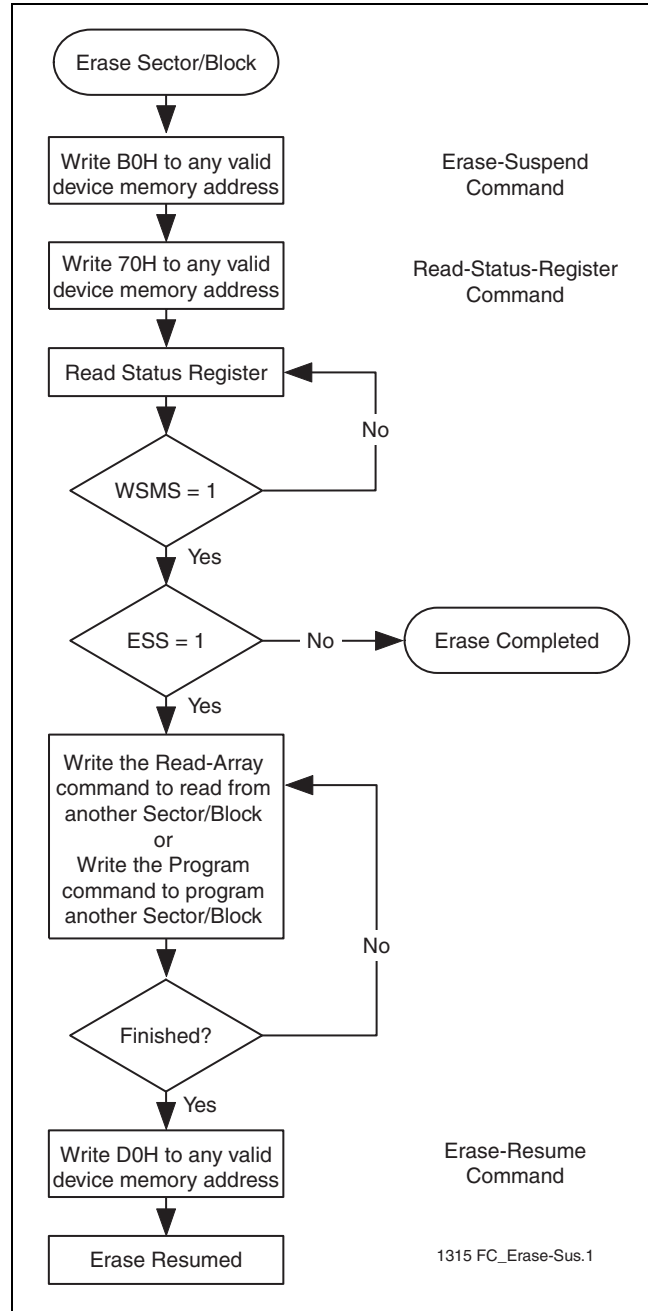

FIGURE 6: Erase-Suspend Flow Chart

TABLE 11: Security ID Addresses

Address Range	Security ID Segment	Size
FFFC 0180 to FFFC 0187	Factory-Programmed	8 bytes – 64 bit
FFFC 0188 to FFFC 019F	User-Programmed	24 bytes – 192 bit

T11.0 1315



Advance Information

**REGISTERS**

There are four types of registers available on the SST49LF160C, General Purpose Inputs registers, Block Locking registers, Security ID register, and the JEDEC ID registers. These registers appear at their respective address location in the 4 GByte system memory map. Unused register locations will read as 00H. Any attempt to read or write any register during an internal Write operation will be ignored.

Read or write access to the register during an internal Program/Erase operation will be completed as follows:

- General Purpose Inputs register, and Block Locking registers can be accessed normally
- Security ID register and the JEDEC ID registers can not be accessed (reading these registers will return unused register data 00H).

**General Purpose Inputs Register**

The General Purpose Inputs register (GPI\_REG) passes the state of GPI[4:0] pins on the SST49LF160C. It is recommended that the GPI[4:0] pins be in the desired state before LFRAME# is brought low for the beginning of the bus cycle, and remain in that state until the end of the cycle. There is no default value since this is a pass-through register. The GPI\_REG register for the boot device appears at FFBC0100H in the 4 GByte system memory map, and will appear elsewhere if the device is not the boot device (see Table 12). This register is not available to be read when the device is in an Erase/Program operation.

**TABLE 12: General Purpose Register**

Register	Register Address <sup>1</sup>	Default Value	Access
GPI_REG	FFBC 0100H	N/A	R

T12.0 1315

1. Address shown in this column is for boot device only. Address locations should appear elsewhere in the 4 GByte system memory map depending on ID strapping values on ID[3:0] pins when multiple LPC memory devices are used in a system.

**Block Locking Registers**

SST49LF160C provides software controlled lock protection through a set of Block Locking registers. The Block Locking Registers are read/write registers and they are accessible through standard addressable memory locations specified in Table 13. Unused register locations will return 00H if read.

**TABLE 13: Block Locking Registers**

Register	Block Size	SST49LF160C Protected Memory Address <sup>1</sup> Range	Memory Map Register Address <sup>1</sup>
T_BLOCK_LK	16K	1FFFFFFH-1FC000H	FFBFC002H
T_MINUS01_LK	8K	1FBFFFH-1FA000H	FFBFA002H
T_MINUS02_LK	8K	1F9FFFH-1F8000H	FFBF8002H
T_MINUS03_LK	32K	1F7FFFH-1F0000H	FFBF0002H
T_MINUS04_LK	64K	1EFFFFH-1E0000H	FFBE0002H
T_MINUS05_LK	64K	1DFFFFH-1D0000H	FFBD0002H
T_MINUS06_LK	64K	1CFFFFH-1C0000H	FFBC0002H
T_MINUS07_LK	64K	1BFFFFH-1B0000H	FFBB0002H
T_MINUS08_LK	64K	1AFFFFH-1A0000H	FFBA0002H
T_MINUS09_LK	64K	19FFFFH-190000H	FFB90002H
T_MINUS10_LK	64K	18FFFFH-180000H	FFB80002H
T_MINUS11_LK	64K	17FFFFH-170000H	FFB70002H
T_MINUS12_LK	64K	16FFFFH-160000H	FFB60002H
T_MINUS13_LK	64K	15FFFFH-150000H	FFB50002H
T_MINUS14_LK	64K	14FFFFH-140000H	FFB40002H
T_MINUS15_LK	64K	13FFFFH-130000H	FFB30002H
T_MINUS16_LK	64K	12FFFFH-120000H	FFB20002H
T_MINUS17_LK	64K	11FFFFH-110000H	FFB10002H
T_MINUS18_LK	64K	10FFFFH-100000H	FFB00002H
T_MINUS19_LK	64K	0FFFFFFH-0F0000H	FFAF0002H
T_MINUS20_LK	64K	0EFFFFH-0E0000H	FFAE0002H
T_MINUS21_LK	64K	0DFFFFH-0D0000H	FFAD0002H
T_MINUS22_LK	64K	0CFFFFH-0C0000H	FFAC0002H
T_MINUS23_LK	64K	0BFFFFH-0B0000H	FFAB0002H
T_MINUS24_LK	64K	0AFFFFH-0A0000H	FFAA0002H
T_MINUS25_LK	64K	09FFFFH-090000H	FFA90002H
T_MINUS26_LK	64K	08FFFFH-080000H	FFA80002H
T_MINUS27_LK	64K	07FFFFH-070000H	FFA70002H
T_MINUS28_LK	64K	06FFFFH-060000H	FFA60002H
T_MINUS29_LK	64K	05FFFFH-050000H	FFA50002H
T_MINUS30_LK	64K	04FFFFH-040000H	FFA40002H
T_MINUS31_LK	64K	03FFFFH-030000H	FFA30002H
T_MINUS32_LK	64K	02FFFFH-020000H	FFA20002H
T_MINUS33_LK	64K	01FFFFH-010000H	FFA10002H
T_MINUS34_LK	64K	00FFFFH-000000H	FFA00002H

T13.0 1315

1. Address shown in this column is for boot device only. Address locations should appear elsewhere in the 4 GByte system memory map depending on ID strapping values on ID[3:0] pins when multiple LPC memory devices are used in a system.



**TABLE 14: Block Locking Register Bits**

Reserved Bit [7:3]	Read-Lock Bit [2]	Lock-Down Bit [1]	Write-Lock Bit [0]	Lock Status
00000	0	0	0	Full Access
00000	0	0	1	Write Locked (Default State at Power-Up)
00000	0	1	0	Locked Open (Full Access Locked Down)
00000	0	1	1	Write Locked Down
00000	1	0	0	Block Read Locked (Registers alterable)
00000	1	0	1	Block Read & Write Lock (Registers alterable)
00000	1	1	0	Block Read Locked Down (Registers not alterable)
00000	1	1	1	Block Read & Write lock Down (Registers not alterable)

T14.0 1315

### Write-Lock Bit

The Write-Lock bit, bit 0, controls the lock state described in Table 14. The default Write status of all blocks after power up is write locked. When bit 0 of the Block Locking register is set, Program and Erase operations for the corresponding block are prevented. Clearing the Write-Lock bit will unprotect the block. The Write-Lock bit must be cleared prior to starting a Program or Erase operation since it is sampled at the beginning of the operation. The Write-Lock bit functions in conjunction with the hardware Write Lock pin TBL# for the top Boot Block. When TBL# is low, it overrides the software locking scheme. The top Boot Block Locking register does not indicate the state of the TBL# pin. The Write-Lock bit functions in conjunction with the hardware WP#/AAI pin for the remaining blocks (Blocks 0 to 33 for SST49LF160C). When WP#/AAI is low, it overrides the software locking scheme. The Block Locking register does not indicate the state of the WP#/AAI pin.

### Lock-Down Bit

The Lock-Down bit, bit 1, controls the Block Locking register as described in Table 14. When in LPC interface mode, the default Lock Down status of all blocks upon power-up is not locked down. Once the Lock-Down bit is set, any future attempted changes to that Block Locking register will be ignored. The Lock-Down bit is only cleared upon a device reset with RST# or INIT# or power down. Current Lock Down status of a particular block can be determined by reading the corresponding Lock-Down bit. Once a block's Lock-Down bit is set, the Read-Lock and Write-Lock bits for that block can no longer be modified: the block is locked down in its current state of read/write accessibility.

### Read-Lock Bit

The default read status of all blocks upon power-up is read-unlocked. When a block's read lock bit is set, data cannot be read from that block. An attempted read from a read-locked block will result in the data 00h. The read lock status can be unlocked by clearing the read lock bit: this can only be done provided that the block is not locked down. The current read lock status of a particular block can be determined by reading the corresponding read-lock bit.



Advance Information

**Security ID Registers**

The SST49LF160C device offers a 256-bit Security ID register space. The Security ID space is divided into two segments - one (64-bits) factory programmed segment and one (192 bits) user programmed segment. The first segment is programmed and locked at SST with a unique 64-bit number. The user segment (192 bits) is left blank (FFH) for the customer to be programmed as desired. Refer to Table 8, "Software Command Sequence" for more details.

The Security ID Information and its Write Lock/Unlock status can be Read in the Register Access Space for Execute-In-Place type of applications. (See Table 15.)

The Write Lock-out status of the Security ID space can be read from the SEC\_ID\_WRITE\_LOCK register (see Table 15). The SEC\_ID\_WRITE\_LOCK register is a read-only register that is accessible at the address location specified in Table 15.

**TABLE 15: Security ID Registers**

Register	Register Address <sup>1</sup>	Value	Access	Description
SEC_ID__WRITE_LOCK	FFBC0102H	0000 0000b 0000 0001b	R	Write Unlocked Write Locked
SEC_ID_BYTE_0	FFBC0180H		R	Factory Programmed
SEC_ID_BYTE_1	FFBC0181H		R	Factory Programmed
SEC_ID_BYTE_2	FFBC0182H		R	Factory Programmed
SEC_ID_BYTE_3	FFBC0183H		R	Factory Programmed
...	...		...	...
SEC_ID_BYTE_7	FFBC0187H		R	Factory Programmed
SEC_ID_BYTE_8	FFBC0188H		R	User Programmed
SEC_ID_BYTE_9	FFBC0189H		R	User Programmed
...	...		...	...
SEC_ID_BYTE_30	FFBC019EH		R	User Programmed
SEC_ID_BYTE_31	FFBC019FH		R	User Programmed

T15.0 1315

1. Address shown in this column is for boot device only. Address locations should appear elsewhere in the 4 GByte system memory map depending on ID strapping values on ID[3:0] pins when multiple LPC memory devices are used in a system.



# 16 Mbit LPC Flash SST49LF160C

Advance Information

## JEDEC ID Registers

The JEDEC ID registers for the boot device appear at FFBC0000H and FFBC0001H in the 4 GByte system memory map, and will appear elsewhere if the device is not the boot device, see Table 17. This register is not available to be read when the device is in Erase/Program operation. Unused register location will read as 00H. See Table 16 for the JEDEC device ID code.

**TABLE 16: JEDEC ID Registers**

Register	Register Address <sup>1</sup>	Default Value	Access
MANUF_REG	FFBC 0000H	BFH	R
DEV_REG	FFBC 0001H	4CH	R

T16.0 1315

1. Address shown in this column is for boot device only. Address locations should appear elsewhere in the 4 GByte system memory map depending on ID strapping values on ID[3:0] pins when multiple LPC memory devices are used in a system.

**TABLE 17: LPC MEMORY MAP REGISTER ADDRESSES**

Device #	Hardware Strapping	SST49LF160C		
		JEDEC ID		
		GPI_REG	MANUF_REG	DEV_REG
0 (Boot device)	0000	FFBC 0100H	FFBC 0000H	FFBC 0001H
1	0001	FF9C 0100H	FF9C 0000H	FF9C 0001H
2	0010	FF3C 0100H	FF3C 0000H	FF3C 0001H
3	0011	FF1C 0100H	FF1C 0000H	FF1C 0001H
4	0100	FEBC 0100H	FEBC 0000H	FEBC 0001H
5	0101	FE9C 0100H	FE9C 0000H	FE9C 0001H
6	0110	FE3C 0100H	FE3C 0000H	FE3C 0001H
7	0111	FE1C 0100H	FE1C 0000H	FE1C 0001H
8	1000	FDBC 0100H	FDBC 0000H	FDBC 0001H
9	1001	FD9C 0100H	FD9C 0000H	FD9C 0001H
10	1010	FD3C 0100H	FD3C 0000H	FD3C 0001H
11	1011	FD1C 0100H	FD1C 0000H	FD1C 0001H
12	1100	FCBC 0100H	FCBC 0000H	FCBC 0001H
13	1101	FC9C 0100H	FC9C 0000H	FC9C 0001H
14	1110	FC3C 0100H	FC3C 0000H	FC3C 0001H
15	1111	FC1C 0100H	FC1C 0000H	FC1C 0001H

T17.0 1315



## AUTO-ADDRESS INCREMENT (AAI) MODE

### AAI Mode with Multi-Byte Programming

AAI mode with multi-byte programming is provided for high-speed production programming. Auto-Address Increment mode requires only one address load for each 128-byte page of data.

Taking the WP#/AAI pin to the Supervoltage  $V_H$  enables the AAI mode. LD# should be low ( $V_{IL}$ ) as long as data is being loaded into the device. In the MADDR field, the host may input any address within the 128-byte page to be programmed. The least significant seven bits of the address field will be ignored and the device will begin programming at the beginning of the 128-byte page (i.e., the address will be page-aligned). The device Ready/Busy status is output on the RY/BY# pin.

Data is accepted until the internal buffer is full. At that point RY/BY# goes low (busy) to indicate that the internal buffer is full and cannot accept any more data. When the device is ready, RY/BY# pin goes high and indicates to the host that more data (the next group of bytes) can be accepted by the internal data buffer (see Table 18 and Figure 7).

After loading the final byte(s) of the 128-byte page, the RY/BY# signal remains low until the completion of internal programming. After the completion of programming, the part will go into idle mode and the RY/BY# will go high indicating that the AAI command has been completed (see Table 18). A subsequent AAI command may be initiated to begin programming the next 128-byte page.

Data will be accepted by the device as long as LD# is low and RY/BY# is high (until the last byte of the 128-byte page has been entered). For partial data-loads (i.e., less than 128 Bytes), LD# may be taken high ( $V_{IH}$ ) to end the data loading. If LD# goes high before the full 128-byte page has been entered, the device will program the data which has been entered to that point, and then terminate the AAI page programming command. Any incompletely loaded data byte (nibble) will not be programmed. The device will signify completion of the command by driving RY/BY# high. Once RY/BY# goes high, LD# can be taken low to begin a new AAI programming operation at a different address location.

The RY/BY# pin will stay low while internal programming completes. When the entire 128-byte page has been programmed, the device will return to the idle mode and the RY/BY# pin will go high ( $V_{IH}$ ) to indicate the AAI command has been completed.

**TABLE 18: LD# Input and RY/BY# Status in AAI Mode**

LD# state	RY/BY# status	RY/BY# Flag indication
L	H	Device is Ready, can accept more data until the last (128 <sup>th</sup> ) byte.
L	L	Device is Busy, cannot accept more data
L	H	Device is Ready for next operation if previous data is the last (128 <sup>th</sup> ) byte.
H	H	Device is Ready for next operation
H	L	Device is Busy programming

T18.1 1315

The user may terminate AAI programming by dropping the WP#/AAI pin to TTL levels ( $V_{IH}/V_{IL}$ ) as long as LD# is high and RY/BY# returns to high indicating the completion of the AAI cycle. Software block-locking will be disabled in AAI mode (all blocks will be write-unlocked). If AAI drops below the Supervoltage  $V_H$  before RY/BY# returns to high (and LD# high), the contents of the page may be indeterminate.



## AAI Data Load Protocol

**TABLE 19: AAI Programming Cycle (initiated with WP#/AAI at V<sub>H</sub> ONLY)**

Clock Cycle	Field Name	Field Contents	LAD[3:0]	Comments
1	START	1110	IN	LFRAME# must be active (low) for the part to respond. Only the last start field (before LFRAME# transitions high) should be recognized.
2	IDSEL	0000b to 1111b	IN	This field indicates which SST49LF160C device should respond. If the IDSEL (ID select) field matches the value of ID[3:0], then that particular device will respond to the whole bus cycle.
3-9	MADDR	YYYY	IN	These seven clock cycles make up the 28-bit memory address. YYYY is one nibble of the entire address. Addresses are transferred most-significant nibble first. Only bits [20:7] of the total address [27:0] are used for AAI mode. The rest are "don't care".
10	MSIZE	KKKK	IN	MSIZE field is don't care when in AAI mode
11-266	DATA	ZZZZ	IN	Data is transmitted to the device least significant nibble first, from byte 0 to byte 127 as long as the RY/BY# is high and LD# low. The host will pause the clock and data stream when RY/BY# goes low until it returns high, signifying that the chip is ready for more data

T19.0 1315

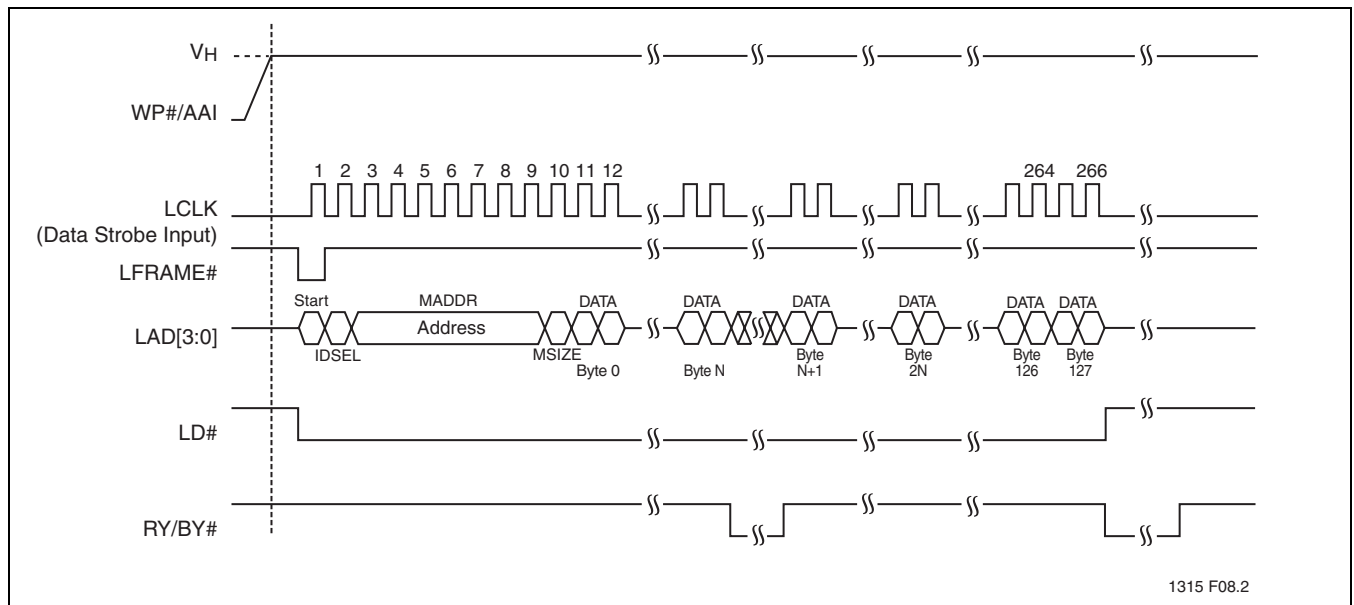

1315 F08.2

**FIGURE 7: AAI Load Protocol Waveform**



Advance Information

**ELECTRICAL SPECIFICATIONS**

The AC and DC specifications for the LPC interface signals (LAD[3:0], LFRAME#, LCLK and RST#) as defined in Section 4.2.2.4 of the PCI local Bus specification, Rev. 2.1. Refer to Table 20 for the DC voltage and current specifications. Refer to Table 24 through Table 26 for the AC timing specifications for Clock, Read, Write, and Reset operations.

**Absolute Maximum Stress Ratings** (Applied conditions greater than those listed under “Absolute Maximum Stress Ratings” may cause permanent damage to the device. This is a stress rating only and functional operation of the device at these conditions or conditions greater than those defined in the operational sections of this data sheet is not implied. Exposure to absolute maximum stress rating conditions may affect device reliability.)

Temperature Under Bias .....	-55°C to +125°C
Storage Temperature .....	-65°C to +150°C
D.C. Voltage on Any Pin to Ground Potential .....	-0.5V to V <sub>DD</sub> +0.5V
Transient Voltage (<20 ns) on Any Pin (except WP#/AAI) to Ground Potential <sup>1</sup> .....	-2.0V to V <sub>DD</sub> +2.0V
Voltage on WP#/AAI Pin to Ground Potential <sup>2</sup> .....	-0.5V to 11.0V
Package Power Dissipation Capability (T <sub>A</sub> =25°C) .....	1.0W
Surface Mount Solder Reflow Temperature <sup>3</sup> .....	260°C for 10 seconds
Output Short Circuit Current <sup>4</sup> .....	50 mA

1. Do not violate processor or chipset specification regarding INIT# voltage.
2. The maximum DC voltage on WP#/AAI pin may reach 11V for periods <20ns.
3. Excluding certain with-Pb 32-PLCC units, all packages are 260°C capable in both non-Pb and with-Pb solder versions.  
Certain with-Pb 32-PLCC package types are capable of 240°C for 10 seconds; please consult the factory for the latest information.
4. Outputs shorted for no more than one second. No more than one output shorted at a time.

**OPERATING RANGE**

Range	Ambient Temp	V <sub>DD</sub>
Commercial	0°C to +85°C	3.0-3.6V

**AC CONDITIONS OF TEST**

Input Rise/Fall Time .....	3 ns
Output Load .....	C <sub>L</sub> = 30 pF
See Figures 13 and 14	

## DC Characteristics

**TABLE 20: DC Operating Characteristics (All Interfaces)**

Symbol	Parameter	Limits			Test Conditions
		Min	Max	Units	
I <sub>DD</sub> <sup>1</sup>	Active V <sub>DD</sub> Current				LCLK (LPC mode)=V <sub>ILT</sub> /V <sub>IHT</sub> at f=33 MHz All other inputs=V <sub>IL</sub> or V <sub>IH</sub>
	Read		18	mA	All outputs = open, V <sub>DD</sub> =V <sub>DD</sub> Max
	Single-Byte Program, Erase		40	mA	f=33 MHz
	AAI		60	mA	f=33 MHz
I <sub>SB</sub>	Standby V <sub>DD</sub> Current (LPC Interface)		100	μA	LCLK (LPC mode)=V <sub>ILT</sub> /V <sub>IHT</sub> at f=33 MHz LFRAME#=0.9V <sub>DD</sub> , f=33 MHz, V <sub>DD</sub> =V <sub>DD</sub> Max All other inputs ≥ 0.9 V <sub>DD</sub> or ≤ 0.1 V <sub>DD</sub>
I <sub>RY</sub> <sup>2</sup>	Ready Mode V <sub>DD</sub> Current		10	mA	LCLK (LPC mode)=V <sub>ILT</sub> /V <sub>IHT</sub> at f=33 MHz LFRAME#=V <sub>IL</sub> , f=33 MHz, V <sub>DD</sub> =V <sub>DD</sub> Max All other inputs ≥ 0.9 V <sub>DD</sub> or ≤ 0.1 V <sub>DD</sub>
I <sub>I</sub>	Input Leakage Current for ID[3:0] pins		200	μA	V <sub>IN</sub> =GND to V <sub>DD</sub> , V <sub>DD</sub> =V <sub>DD</sub> Max
I <sub>LI</sub>	Input Leakage Current		1	μA	V <sub>IN</sub> =GND to V <sub>DD</sub> , V <sub>DD</sub> =V <sub>DD</sub> Max
I <sub>LO</sub>	Output Leakage Current		1	μA	V <sub>OUT</sub> =GND to V <sub>DD</sub> , V <sub>DD</sub> =V <sub>DD</sub> Max
I <sub>H</sub>	Supervoltage Current for WP#/AAI		200	μA	
V <sub>H</sub>	Supervoltage for WP#/AAI	8.5	9.5	V	
V <sub>IHI</sub> <sup>3</sup>	INIT# Input High Voltage	1.1	V <sub>DD</sub> +0.5	V	V <sub>DD</sub> =V <sub>DD</sub> Max
V <sub>ILI</sub> <sup>3</sup>	INIT# Input Low Voltage	-0.5	0.4	V	V <sub>DD</sub> =V <sub>DD</sub> Min
V <sub>IL</sub>	Input Low Voltage	-0.5	0.3 V <sub>DD</sub>	V	V <sub>DD</sub> =V <sub>DD</sub> Min
V <sub>IH</sub>	Input High Voltage	0.5 V <sub>DD</sub>	V <sub>DD</sub> +0.5	V	V <sub>DD</sub> =V <sub>DD</sub> Max
V <sub>OL</sub>	Output Low Voltage		0.1 V <sub>DD</sub>	V	I <sub>OL</sub> =1500 μA, V <sub>DD</sub> =V <sub>DD</sub> Min
V <sub>OH</sub>	Output High Voltage	0.9 V <sub>DD</sub>		V	I <sub>OH</sub> =-500 μA, V <sub>DD</sub> =V <sub>DD</sub> Min

T21.0 1315

1. I<sub>DD</sub> active while a Read or Write (Program or Erase) operation is in progress.
2. The device is in Ready mode when no activity is on the LPC bus.
3. Do not violate processor or chipset specification regarding INIT# voltage.

**TABLE 21: Recommended System Power-up Timings**

Symbol	Parameter	Minimum	Units
T <sub>PU-READ</sub> <sup>1</sup>	Power-up to Read Operation	100	μs
T <sub>PU-WRITE</sub> <sup>1</sup>	Power-up to Write Operation	100	μs

T21.0 1315

1. This parameter is measured only for initial qualification and after a design or process change that could affect this parameter

**TABLE 22: Pin Capacitance (V<sub>DD</sub>=3.3V, T<sub>A</sub>=25 °C, f=1 Mhz, other pins open)**

Parameter	Description	Test Condition	Maximum
C <sub>I/O</sub> <sup>1</sup>	I/O Pin Capacitance	V <sub>I/O</sub> =0V	12 pF
C <sub>IN</sub> <sup>1</sup>	Input Capacitance	V <sub>IN</sub> =0V	12 pF
L <sub>PIN</sub> <sup>2</sup>	Pin Inductance		20 nH

T22.0 1315

1. This parameter is measured only for initial qualification and after a design or process change that could affect this parameter.
2. Refer to PCI spec.



Advance Information

**TABLE 23: Reliability Characteristics**

Symbol	Parameter	Minimum Specification	Units	Test Method
$N_{END}^1$	Endurance	10,000	Cycles	JEDEC Standard A117
$T_{DR}^1$	Data Retention	100	Years	JEDEC Standard A103
$I_{LTH}^1$	Latch Up	$100 + I_{DD}$	mA	JEDEC Standard 78

T23.0 1315

1. This parameter is measured only for initial qualification and after a design or process change that could affect this parameter.

**TABLE 24: Clock Timing Parameters (LPC Mode)**

Symbol	Parameter	Min	Max	Units
$T_{CYC}$	Cycle Time	30		ns
$T_{HIGH}$	LCLK High Time	11		ns
$T_{LOW}$	LCLK Low Time	11		ns
-	LCLK Slew Rate (peak-to-peak)	1	4	V/ns
-	RST# or INIT# Slew Rate	50		mV/ns

T24.0 1315

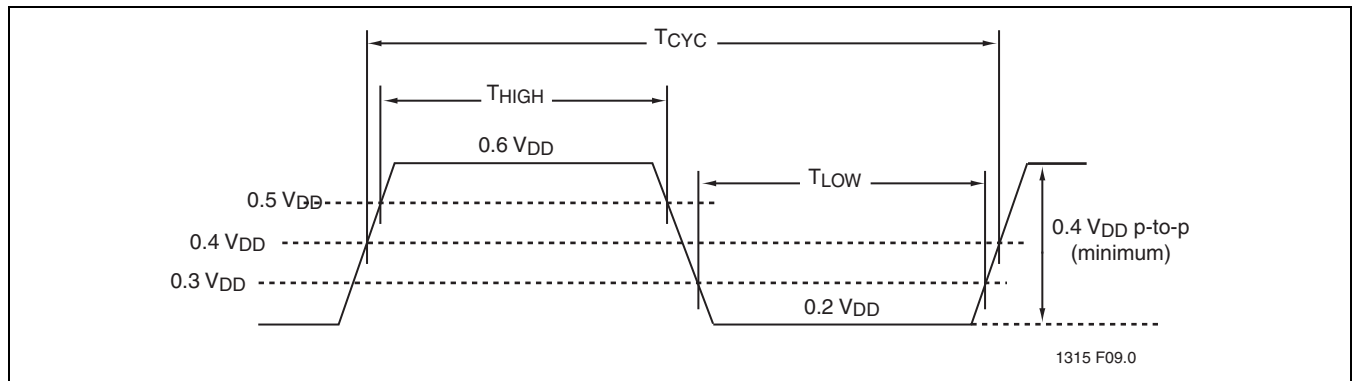

**FIGURE 8: LCLK Waveform (LPC Mode)**

TABLE 25: Reset Timing Parameters,  $V_{DD}=3.0-3.6V$  (LPC Mode)

Symbol	Parameter	Min	Max	Units
$T_{PRST}$	$V_{DD}$ stable to Reset High	100		$\mu s$
$T_{RSTP}$	RST# Pulse Width	100		ns
$T_{RSTF}$	RST# Low to Output Float		48	ns
$T_{RST}^1$	RST# High to LFRAME# Low	5		LCLK cycles
$T_{RSTE}$	RST# Low to reset during Sector-/Block-Erase or Program		10	$\mu s$

T25.0 1315

1. There will be a latency due to  $T_{RSTE}$  if a reset procedure is performed during a Program or Erase operation,

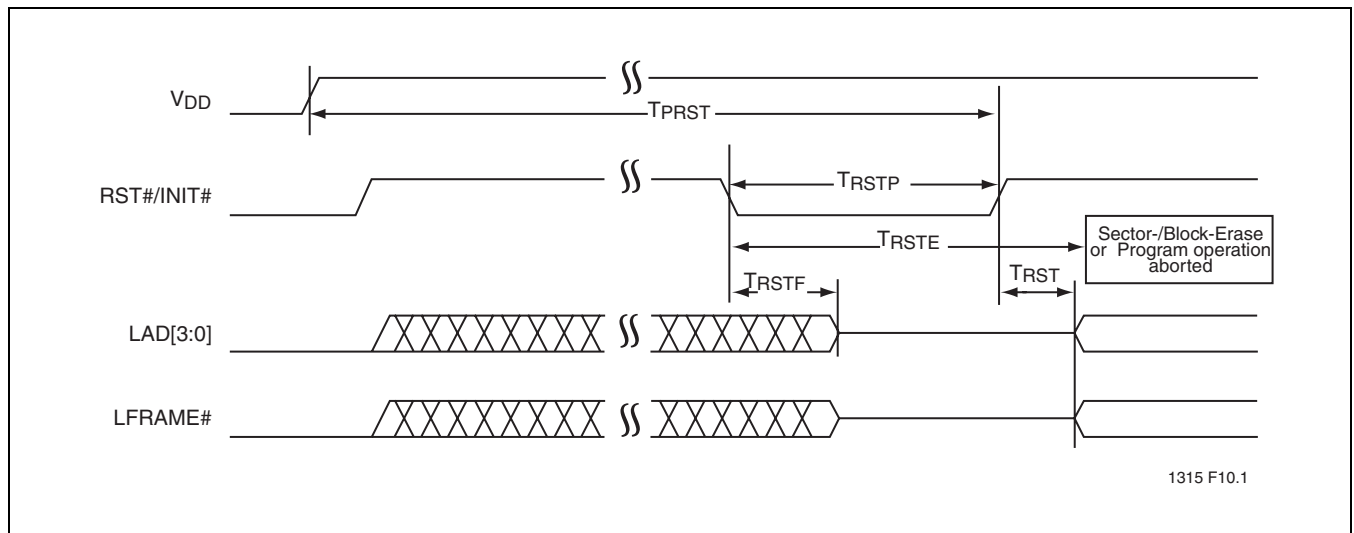

1315 F10.1

FIGURE 9: Reset Timing Diagram (LPC Mode)



Advance Information

AC Characteristics

TABLE 26: Read/Write Cycle Timing Parameters,  $V_{DD}=3.0-3.6V$  (LPC Mode)

Symbol	Parameter	Min	Max	Units
$T_{CYC}$	Clock Cycle Time	30		ns
$T_{SU}$	Data Set Up Time to Clock Rising	7		ns
$T_{DH}$	Clock Rising to Data Hold Time	0		ns
$T_{VAL}^1$	Clock Rising to Data Valid	2	11	ns
$T_{BP}$	Byte Programming Time		10	$\mu s$
$T_{SE}$	Sector-Erase Time		25	ms
$T_{BE}$	Block-Erase Time		25	ms
$T_{ES}$	Program/Erase-Suspend Latency		10	$\mu s$
$T_{ON}$	Clock Rising to Active (Float to Active Delay)	2		ns
$T_{OFF}$	Clock Rising to Inactive (Active to Float Delay)		28	ns

T26.0 1315

1. Minimum and maximum times have different loads. See PCI spec

TABLE 27: AC Input/Output Specifications (LPC Mode)

Symbol	Parameter	Min	Max	Units	Conditions
$I_{OH}(AC)$	Switching Current High  (Test Point)	$-12 V_{DD}$	Equation C <sup>1</sup>	mA	$0 < V_{OUT} \leq 0.3V_{DD}$
		$-17.1(V_{DD}-V_{OUT})$		mA	$0.3V_{DD} < V_{OUT} < 0.9V_{DD}$
		$-32 V_{DD}$		mA	$0.7V_{DD} < V_{OUT} < V_{DD}$ $V_{OUT} = 0.7V_{DD}$
$I_{OL}(AC)$	Switching Current Low  (Test Point)	$16 V_{DD}$	Equation D <sup>1</sup>	mA	$V_{DD} > V_{OUT} \geq 0.6V_{DD}$
		$26.7 V_{OUT}$		mA	$0.6V_{DD} > V_{OUT} > 0.1V_{DD}$
				mA	$0.18V_{DD} > V_{OUT} > 0$ $V_{OUT} = 0.18V_{DD}$
$I_{CL}$	Low Clamp Current	$-25+(V_{IN}+1)/0.015$		mA	$-3 < V_{IN} \leq -1$
$I_{CH}$	High Clamp Current	$25+(V_{IN}-V_{DD}-1)/0.015$		mA	$V_{DD}+4 > V_{IN} \geq V_{DD}+1$
$slew^2$	Output Rise Slew Rate	1	4	V/ns	0.2 $V_{DD}$ -0.6 $V_{DD}$ load
$slew^2$	Output Fall Slew Rate	1	4	V/ns	0.6 $V_{DD}$ -0.2 $V_{DD}$ load

T27.0 1315

1. See PCI spec.

2. PCI specification output load is used.

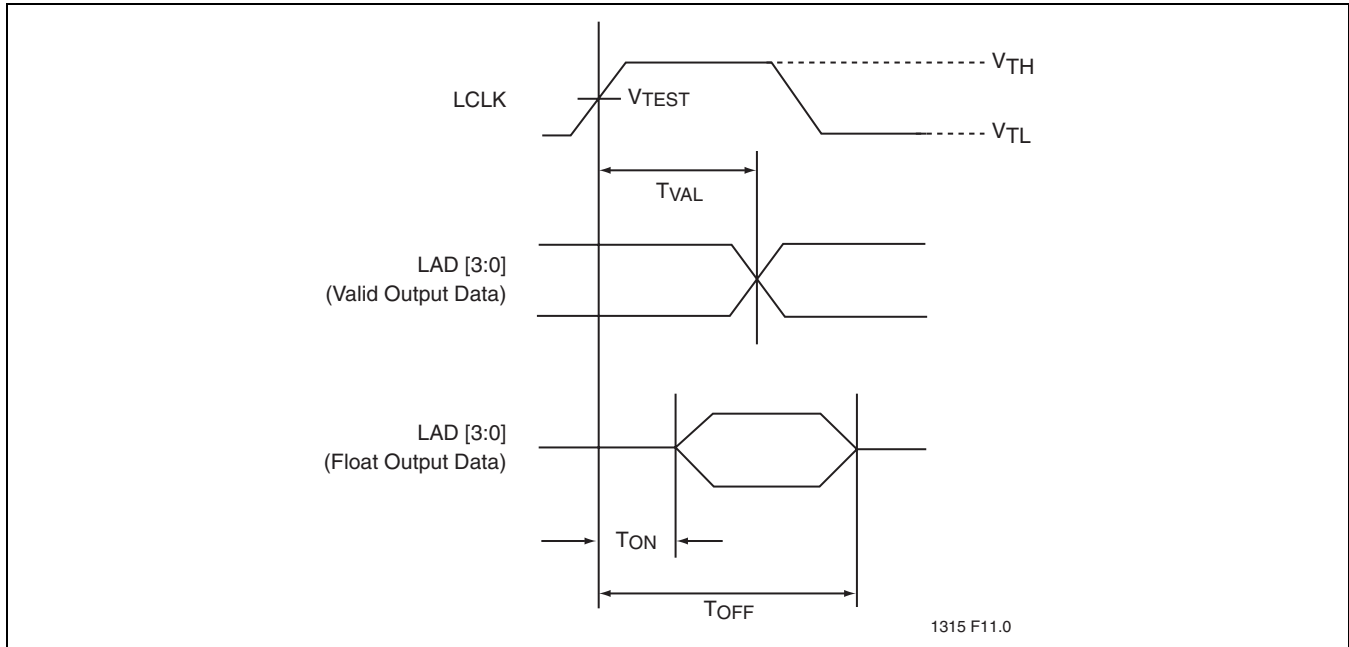

FIGURE 10: Output Timing parameters (LPC Mode)

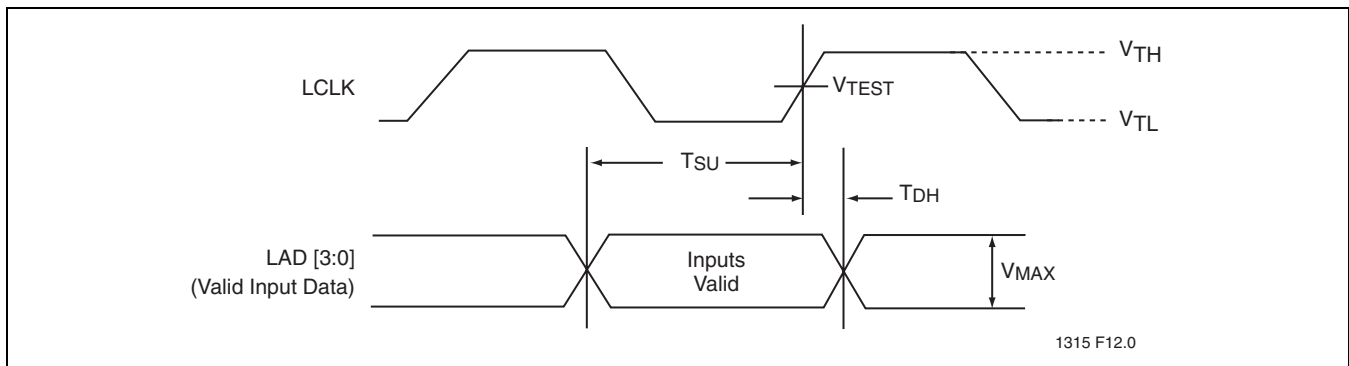

FIGURE 11: Input Timing Parameters (LPC Mode)

TABLE 28: Interface Measurement Condition Parameters (LPC Mode)

Symbol	Value	Units
$V_{TH}^1$	$0.6 V_{DD}$	V
$V_{TL}^1$	$0.2 V_{DD}$	V
$V_{TEST}$	$0.4 V_{DD}$	V
$V_{MAX}^1$	$0.4 V_{DD}$	V
Input Signal Edge Rate	1	V/ns

T28.0 1315

1. The input test environment is done with  $0.1 V_{DD}$  of overdrive over  $V_{IH}$  and  $V_{IL}$ . Timing parameters must be met with no more overdrive than this.  $V_{MAX}$  specifies the maximum peak-to-peak waveform allowed for measuring input timing. Production testing may use different voltage values, but must correlate results back to these parameters.



Advance Information

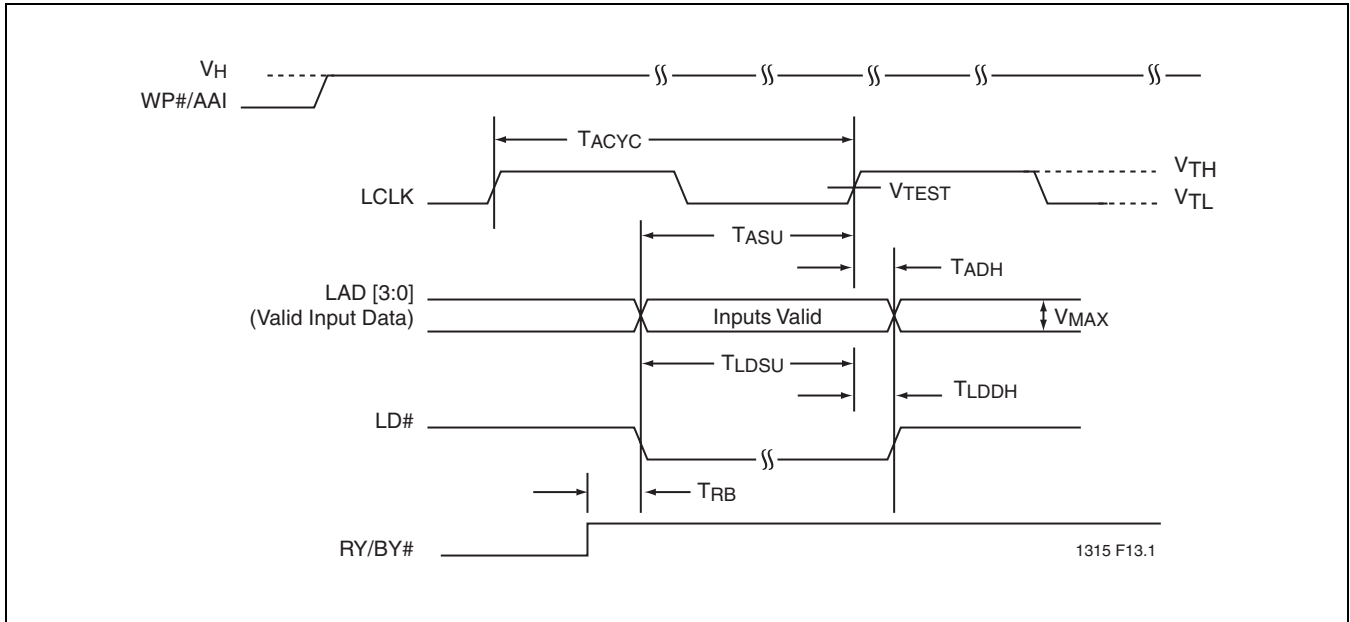

FIGURE 12: Input Timing Parameters (AAI Mode)

TABLE 29: Input Cycle Timing Parameters,  $V_{DD}=3.0-3.6V$  (AAI Mode)

Symbol	Parameter	Min	Max	Units
$T_{ACYC}$	Clock Cycle Time	135		ns
$T_{ASU}$	Data Set Up Time to Clock Rising	25		ns
$T_{ADH}$	Clock Rising to Data Hold Time	25		ns
$T_{RB}$	RY/BY# LD# Falling	25		ns
$T_{LDHU}$	LD# Set Up Time	25		ns
$T_{LDH}$	LD# Hold Time	25		ns

T29.3 1315



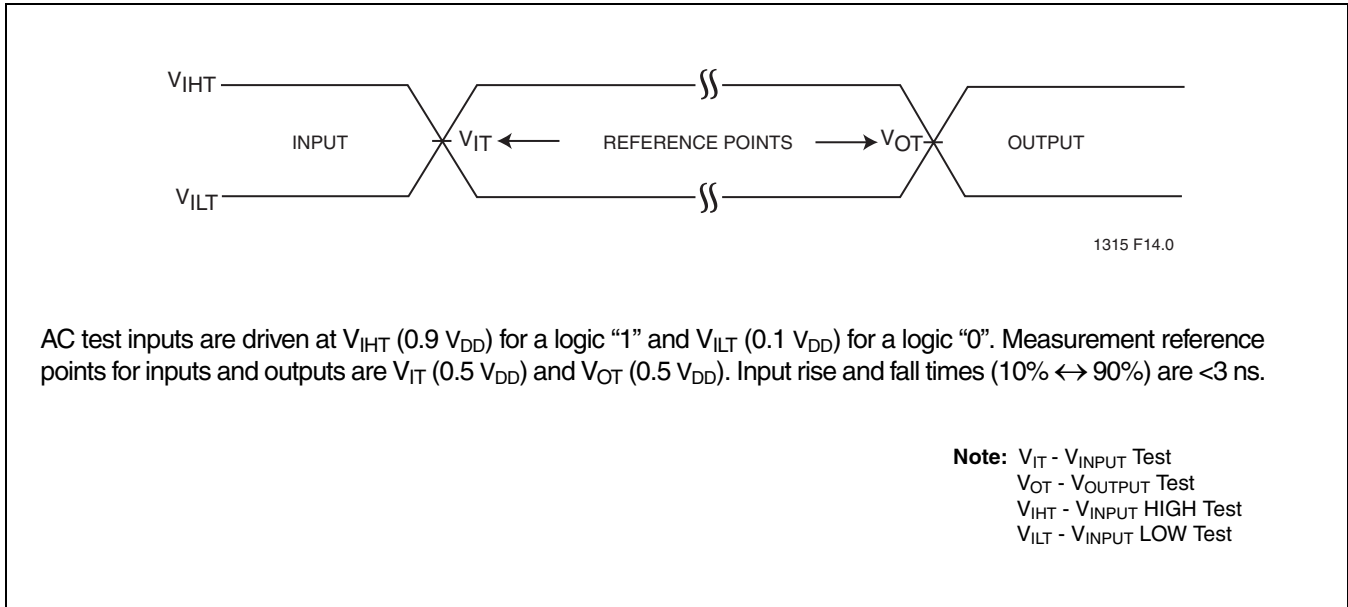

FIGURE 13: AC Input/Output Reference Waveforms

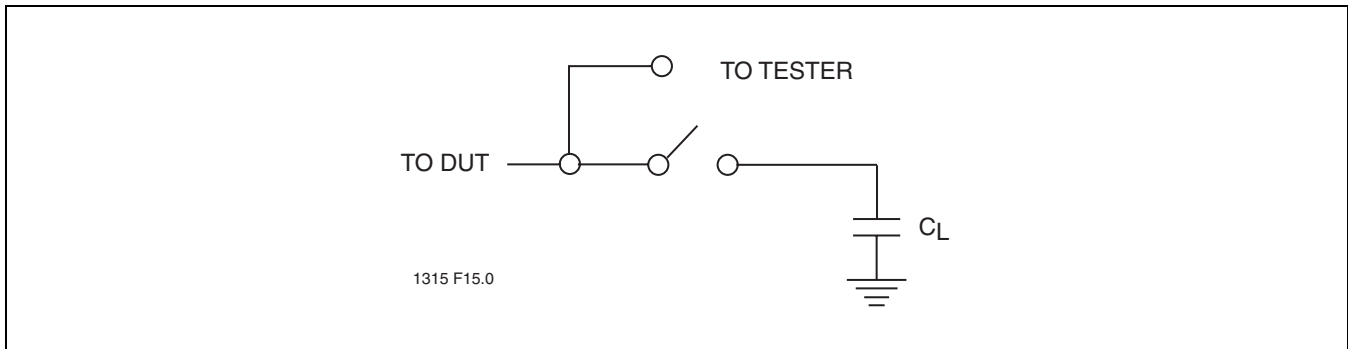
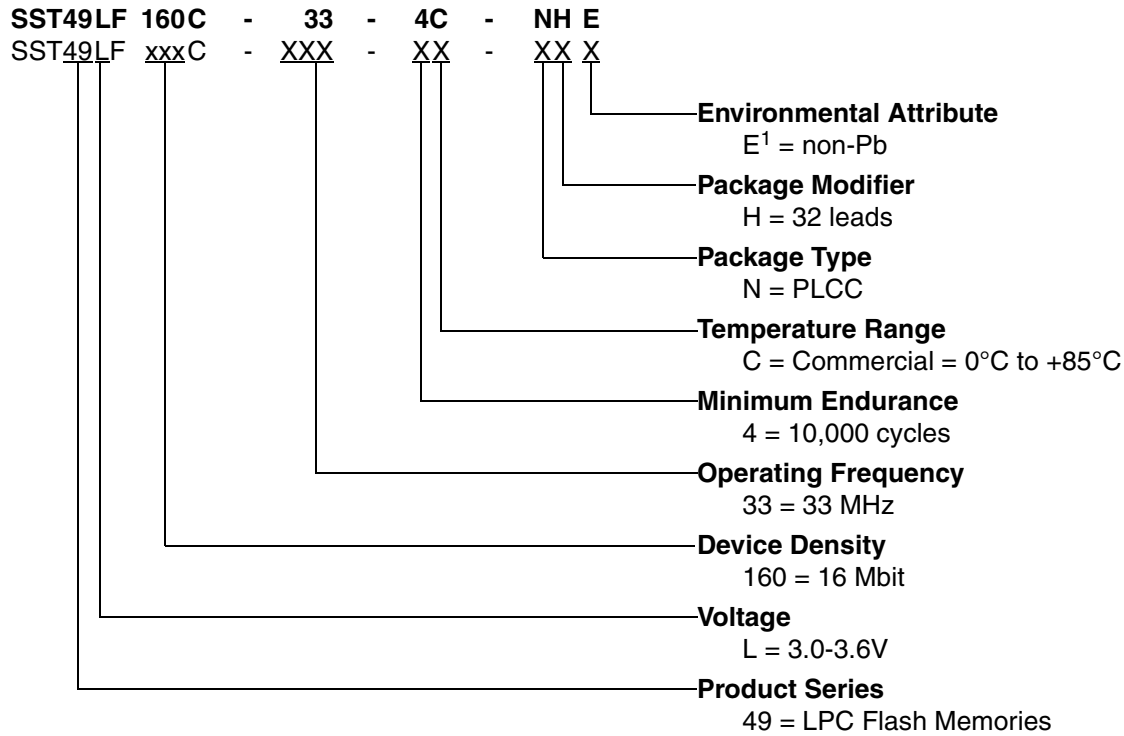

FIGURE 14: A Test Load Example



Advance Information

**PRODUCT ORDERING INFORMATION**



---

1. Environmental suffix "E" denotes non-Pb solder.  
SST non-Pb solder devices are "RoHS Compliant".

**Valid combinations for SST49LF160C**

SST49LF160C-33-4C-NHE

**Note:** Valid combinations are those products in mass production or will be in mass production. Consult your SST sales representative to confirm availability of valid combinations and to determine availability of new combinations.

PACKAGING DIAGRAMS

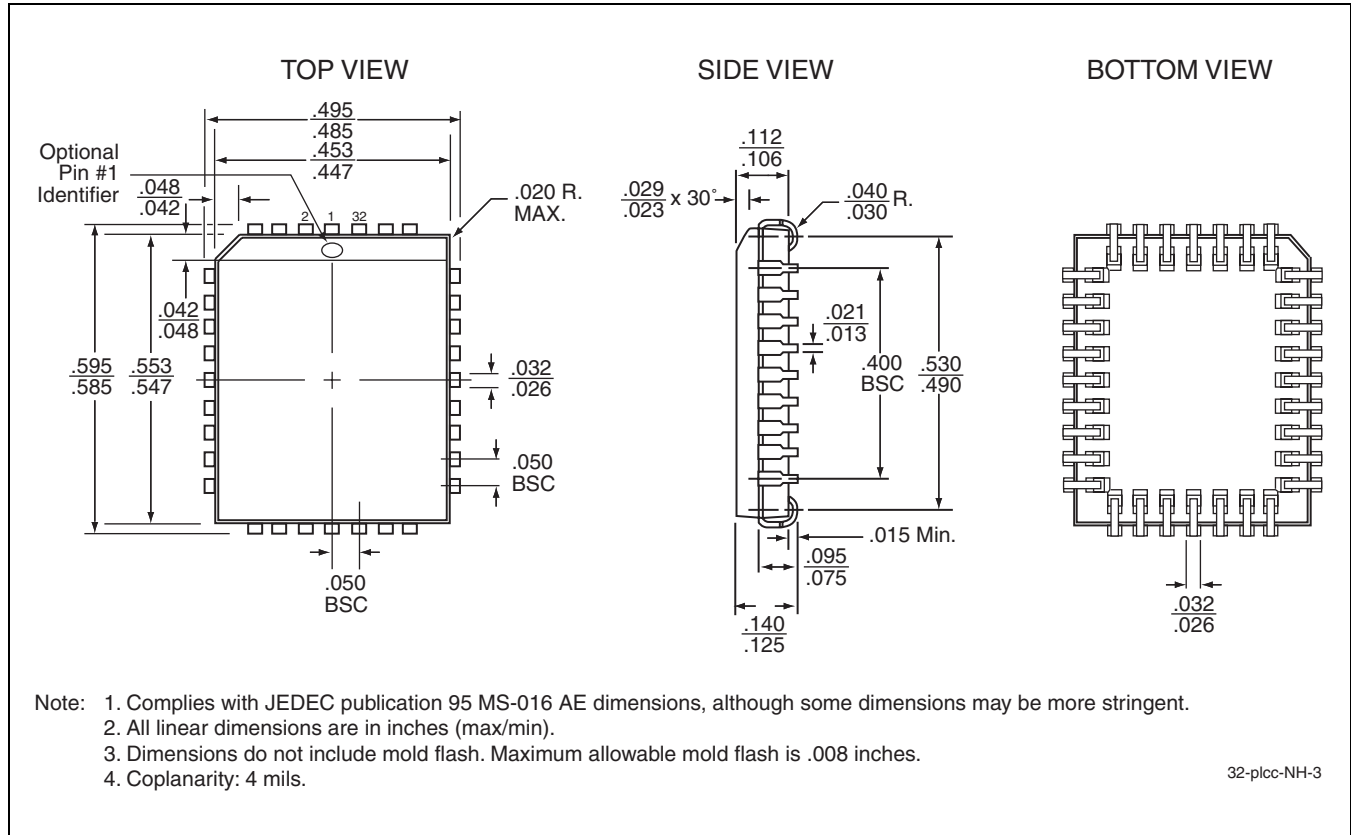

FIGURE 15: 32-lead Plastic Lead Chip Carrier (PLCC)  
SST Package Code: NH

TABLE 30: Revision History

Revision	Description	Date
00	• S71315: Initial release of data sheet (Advance Information)	Apr 2006