

# **128M(8Mx16) GDDR SDRAM**

## **HY5DV281622DT**

## Revision History

| Revision No. | History   | Draft Date | Remark |
|--------------|---|------------|--------|
| 0.1          | Defined Preliminary Specification                                 | May. 2002  |        |
| 0.2          | Defined Target AC, DC spec.                                       | Nov. 2002  |        |
| 0.3          | Changed tCK_max. value of HY5DV281622DT-4/5/6 from 7.5ns to 7.0ns | Feb. 2003  |        |
| 0.4          | Changed VDD/VDDQ max range of HY5DV281622DT-33/36                 | Aug. 2003  |        |
| 0.5          | Changed tRAS_max Value from 120K to 100K in All Frequency         | Aug. 2003  |        |

## DESCRIPTION

The Hynix HY5DV281622 is a 134,217,728-bit CMOS Double Data Rate(DDR) Synchronous DRAM, ideally suited for the point-to-point applications which requires high bandwidth.

The Hynix 8Mx16 DDR SDRAMs offer fully synchronous operations referenced to both rising and falling edges of the clock. While all addresses and control inputs are latched on the rising edges of the CK (falling edges of the /CK), Data, Data strobes and Write data masks inputs are sampled on both rising and falling edges of it. The data paths are internally pipelined and 2-bit prefetched to achieve very high bandwidth. All input and output voltage levels are compatible with SSTL\_2.

## FEATURES

- 3.3V for VDD and 2.5V for VDDQ power supply
- All inputs and outputs are compatible with SSTL\_2 interface
- JEDEC standard 400mil 66pin TSOP-II with 0.65mm pin pitch
- Fully differential clock inputs (CK, /CK) operation
- Double data rate interface
- Source synchronous - data transaction aligned to bidirectional data strobe (DQS)
- x16 device has 2 byte-wide data strobes (LDQS, UDQS) per each x8 I/O
- Data outputs on DQS edges when read (edged DQ)  
Data inputs on DQS centers when write (centered DQ)
- Data(DQ) and Write masks(DM) latched on the both rising and falling edges of the data strobe
- All addresses and control inputs except Data, Data strobes and Data masks latched on the rising edges of the clock
- Write mask byte controls by LDM and UDM
- Programmable /CAS latency 3 / 4 supported
- Programmable Burst Length 2 / 4 / 8 with both sequential and interleave mode
- Internal 4 bank operations with single pulsed /RAS
- tRAS Lock-Out function supported
- Auto refresh and self refresh supported
- 4096 refresh cycles / 32ms
- Full, Half and Matched Impedance(Weak) strength driver option controlled by EMRS

## ORDERING INFORMATION

| Part No.         | Power Supply          | Clock Frequency | Max Data Rate | interface | Package                 |
|------------------|-----------------------|-----------------|---------------|-----------|-------------------------|
| HY5DV281622DT-33 | VDD=3.3V<br>VDDQ=2.5V | 300MHz          | 600Mbps/pin   | SSTL-2    | 400mil 66pin<br>TSOP-II |
| HY5DV281622DT-36 |                       | 275MHz          | 550Mbps/pin   |           |                         |
| HY5DV281622DT-4  |                       | 250MHz          | 500Mbps/pin   |           |                         |
| HY5DV281622DT-5  |                       | 200MHz          | 400Mbps/pin   |           |                         |
| HY5DV281622DT-6  |                       | 166MHz          | 333Mbps/pin   |           |                         |

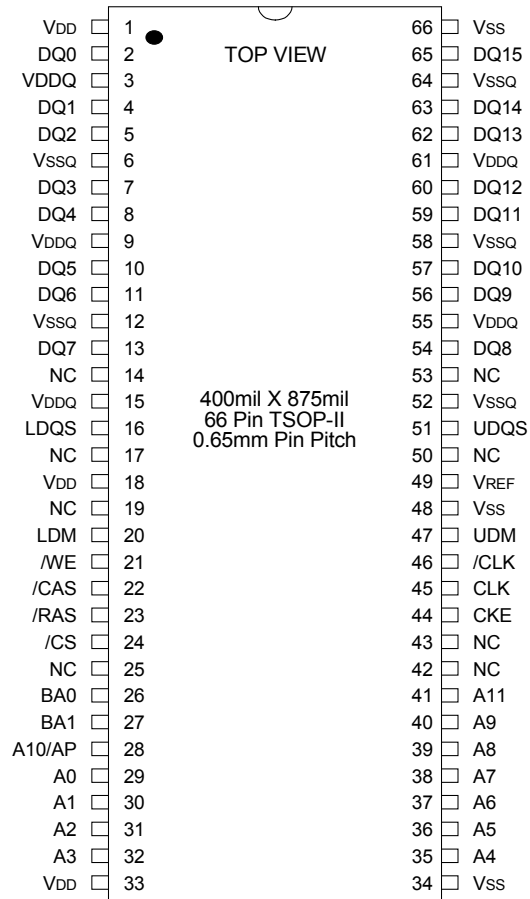
**PIN CONFIGURATION**

**ROW and COLUMN ADDRESS TABLE**

| Items                      | 8Mx16            |
|----------------------------|------------------|
| <b>Organization</b>        | 2M x 16 x 4banks |
| <b>Row Address</b>         | A0 ~ A11         |
| <b>Column Address</b>      | A0 ~ A8          |
| <b>Bank Address</b>        | BA0, BA1         |
| <b>Auto Precharge Flag</b> | A10              |
| <b>Refresh</b>             | 4K               |

**PIN DESCRIPTION**

| PIN             | TYPE   | DESCRIPTION  |
|-----------------|--------|--|
| CK, /CK         | Input  | Clock: CK and /CK are differential clock inputs. All address and control input signals are sampled on the crossing of the positive edge of CK and negative edge of /CK. Output (read) data is referenced to the crossings of CK and /CK (both directions of crossing).   |
| CKE             | Input  | Clock Enable: CKE HIGH activates, and CKE LOW deactivates internal clock signals, and device input buffers and output drivers. Taking CKE LOW provides PRECHARGE POWER DOWN and SELF REFRESH operation (all banks idle), or ACTIVE POWER DOWN (row ACTIVE in any bank). CKE is synchronous for POWER DOWN entry and exit, and for SELF REFRESH entry. CKE is asynchronous for SELF REFRESH exit, and for output disable. CKE must be maintained high throughout READ and WRITE accesses. Input buffers, excluding CK, /CK and CKE are disabled during POWER DOWN. Input buffers, excluding CKE are disabled during SELF REFRESH. CKE is an SSTL_2 input, but will detect an LVCMOS LOW level after Vdd is applied. |
| /CS             | Input  | Chip Select : Enables or disables all inputs except CK, /CK, CKE, DQS and DM. All commands are masked when CS is registered high. CS provides for external bank selection on systems with multiple banks. CS is considered part of the command code.   |
| BA0, BA1        | Input  | Bank Address Inputs: BA0 and BA1 define to which bank an ACTIVE, Read, Write or PRECHARGE command is being applied.  |
| A0 ~ A11        | Input  | Address Inputs: Provide the row address for ACTIVE commands, and the column address and AUTO PRECHARGE bit for READ/WRITE commands, to select one location out of the memory array in the respective bank. A10 is sampled during a precharge command to determine whether the PRECHARGE applies to one bank (A10 LOW) or all banks (A10 HIGH). If only one bank is to be precharged, the bank is selected by BA0, BA1. The address inputs also provide the op code during a MODE REGISTER SET command. BA0 and BA1 define which mode register is loaded during the MODE REGISTER SET command (MRS or EMRS).  |
| /RAS, /CAS, /WE | Input  | Command Inputs: /RAS, /CAS and /WE (along with /CS) define the command being entered.  |
| LDM, UDM        | Input  | Input Data Mask: DM(LDM,UDM) is an input mask signal for write data. Input data is masked when DM is sampled HIGH along with that input data during a WRITE access. DM is sampled on both edges of DQS. Although DM pins are input only, the DM loading matches the DQ and DQS loading. LDM corresponds to the data on DQ0-Q7; UDM corresponds to the data on DQ8-Q15.   |
| LDQS, UDQS      | I/O    | Data Strobe: Output with read data, input with write data. Edge aligned with read data, centered in write data. Used to capture write data. LDQS corresponds to the data on DQ0-Q7; UDQS corresponds to the data on DQ8-Q15.   |
| DQ0 ~ DQ15      | I/O    | Data input / output pin : Data Bus   |
| VDD/VSS         | Supply | Power supply for internal circuits and input buffers.  |
| VDDQ/VSSQ       | Supply | Power supply for output buffers for noise immunity.  |
| VREF            | Supply | Reference voltage for inputs for SSTL interface.   |
| NC              | NC     | No connection.   |

### FUNCTIONAL BLOCK DIAGRAM

4Banks x 2Mbit x 16 I/O Double Data Rate Synchronous DRAM

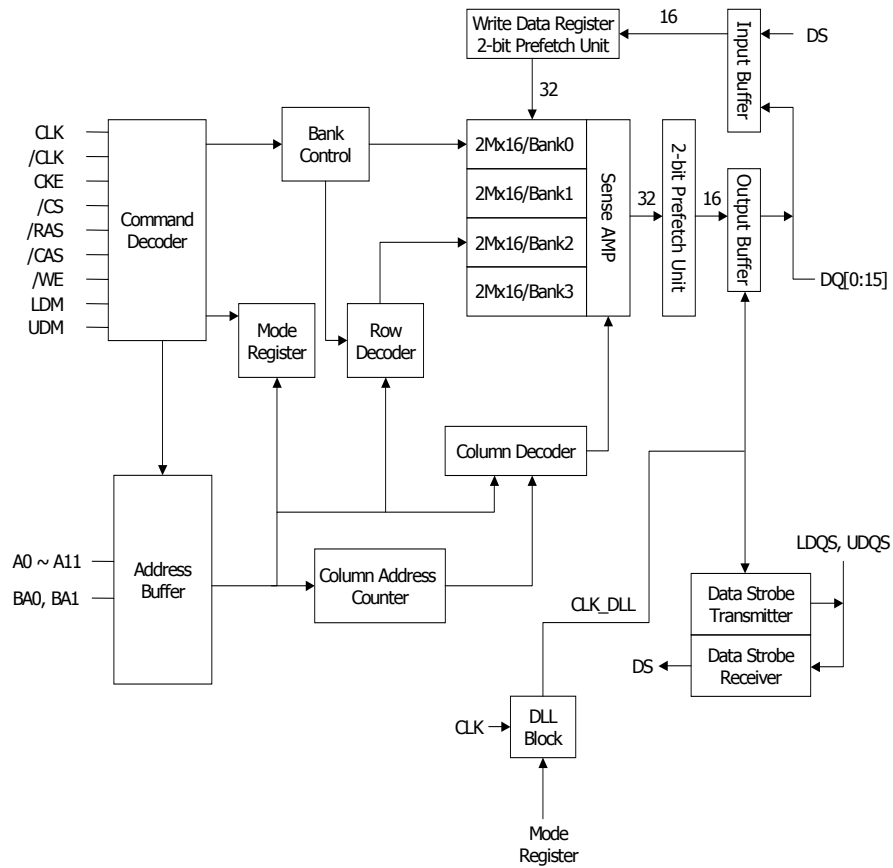

**SIMPLIFIED COMMAND TRUTH TABLE**

| Command                    | CKEn-1 | CKEn | CS | RAS | CAS | WE | ADDR    | A10/<br>AP | BA | Note |
|----------------------------|--------|------|----|-----|-----|----|---------|------------|----|------|
| Extended Mode Register Set | H      | X    | L  | L   | L   | L  | OP code |            |    | 1,2  |
| Mode Register Set          | H      | X    | L  | L   | L   | L  | OP code |            |    | 1,2  |
| Device Deselect            | H      | X    | H  | X   | X   | X  | X       |            |    | 1    |
| No Operation               |        |      | L  | H   | H   | H  |         |            |    |      |
| Bank Active                | H      | X    | L  | L   | H   | H  | RA      |            | V  | 1    |
| Read                       | H      | X    | L  | H   | L   | H  | CA      | L          | V  | 1    |
| Read with Autoprecharge    |        |      |    |     |     |    |         | H          |    | 1,3  |
| Write                      | H      | X    | L  | H   | L   | L  | CA      | L          | V  | 1    |
| Write with Autoprecharge   |        |      |    |     |     |    |         | H          |    | 1,4  |
| Precharge All Banks        | H      | X    | L  | L   | H   | L  | X       | H          | X  | 1,5  |
| Precharge selected Bank    |        |      |    |     |     |    |         | L          | V  | 1    |
| Read Burst Stop            | H      | X    | L  | H   | H   | L  | X       |            |    | 1    |
| Auto Refresh               | H      | H    | L  | L   | L   | H  | X       |            |    | 1    |
| Self Refresh               | Entry  | H    | L  | L   | L   | L  | H       | X          |    | 1    |
|                            | Exit   | L    | H  | H   | X   | X  | X       |            |    | 1    |
| Precharge Power Down Mode  | Entry  |      |    | H   | L   | H  | X       | X          | X  | X    |
|                            |        | L    | H  |     |     | H  | H       | 1          |    |      |
|                            | Exit   | L    | H  | H   | X   | X  | X       | 1          |    |      |
|                            |        |      |    | L   | H   | H  | H       | 1          |    |      |
| Active Power Down Mode     | Entry  | H    | L  | H   | X   | X  | X       | X          |    | 1    |
|                            |        |      |    | L   | V   | V  | V       |            |    | 1    |
|                            | Exit   | L    | H  | X   |     |    | 1       |            |    |      |

( H=Logic High Level, L=Logic Low Level, X=Don't Care, V=Valid Data Input, OP Code=Operand Code, NOP=No Operation )

**Note :**

- LDM/UDM states are Don't Care. Refer to below Write Mask Truth Table.
- OP Code(Operand Code) consists of A0~A11 and BA0~BA1 used for Mode Register setting during Extended MRS or MRS. Before entering Mode Register Set mode, all banks must be in a precharge state and MRS command can be issued after tRP period from Prechagre command.
- If a Read with Autoprecharge command is detected by memory component in CK(n), then there will be no command presented to activated bank until CK(n+BL/2+tRP).
- If a Write with Autoprecharge command is detected by memory component in CK(n), then there will be no command presented to activated bank until CK(n+BL/2+1+tDPL+tRP). Last Data-In to Prechagre delay(tDPL) which is also called Write Recovery Time (tWR) is needed to guarantee that the last data has been completely written.
- If A10/AP is High when Precharge command being issued, BA0/BA1 are ignored and all banks are selected to be precharged.

**WRITE MASK TRUTH TABLE**

| Function                                 | CKEn-1 | CKEn | /CS, /RAS, /CAS, /WE | LDM | UDM | ADDR | A10/<br>AP | BA | Note |
|--|--------|------|----------------------|-----|-----|------|------------|----|------|
| Data Write                               | H      | X    | X                    | L   | L   |      | X          |    | 1,2  |
| Data-In Mask                             | H      | X    | X                    | H   | H   |      | X          |    | 1,2  |
| Lower Byte Write /<br>Upper Byte-In Mask | H      | X    | X                    | L   | H   |      | X          |    | 1,2  |
| Upper Byte Write /<br>Lower Byte-In Mask | H      | X    | X                    | H   | L   |      | X          |    | 1,2  |

**Note :**

1. Write Mask command masks burst write data with reference to LDQS/UDQS(Data Strokes) and it is not related with read data.
2. LDM and UDM control lower byte(DQ0~7) and Upper byte(DQ8~15) respectively.



**OPERATION COMMAND TRUTH TABLE - I**

| Current State | /CS | /RAS | /CAS | /WE | Address    | Command       | Action  |
|---------------|-----|------|------|-----|------------|---------------|---|
| IDLE          | H   | X    | X    | X   | X          | DSEL          | NOP or power down <sup>3</sup>                |
|               | L   | H    | H    | H   | X          | NOP           | NOP or power down <sup>3</sup>                |
|               | L   | H    | H    | L   | X          | BST           | ILLEGAL <sup>4</sup>                          |
|               | L   | H    | L    | H   | BA, CA, AP | READ/READAP   | ILLEGAL <sup>4</sup>                          |
|               | L   | H    | L    | L   | BA, CA, AP | WRITE/WRITEAP | ILLEGAL <sup>4</sup>                          |
|               | L   | L    | H    | H   | BA, RA     | ACT           | Row Activation                                |
|               | L   | L    | H    | L   | BA, AP     | PRE/PALL      | NOP   |
|               | L   | L    | L    | H   | X          | AREF/SREF     | Auto Refresh or Self Refresh <sup>5</sup>     |
| ROW ACTIVE    | L   | L    | L    | L   | OPCODE     | MRS           | Mode Register Set                             |
|               | H   | X    | X    | X   | X          | DSEL          | NOP   |
|               | L   | H    | H    | H   | X          | NOP           | NOP   |
|               | L   | H    | H    | L   | X          | BST           | ILLEGAL <sup>4</sup>                          |
|               | L   | H    | L    | H   | BA, CA, AP | READ/READAP   | Begin read : optional AP <sup>6</sup>         |
|               | L   | H    | L    | L   | BA, CA, AP | WRITE/WRITEAP | Begin write : optional AP <sup>6</sup>        |
|               | L   | L    | H    | H   | BA, RA     | ACT           | ILLEGAL <sup>4</sup>                          |
|               | L   | L    | H    | L   | BA, AP     | PRE/PALL      | Precharge <sup>7</sup>                        |
| READ          | L   | L    | L    | H   | X          | AREF/SREF     | ILLEGAL <sup>11</sup>                         |
|               | L   | L    | L    | L   | OPCODE     | MRS           | ILLEGAL <sup>11</sup>                         |
|               | H   | X    | X    | X   | X          | DSEL          | Continue burst to end                         |
|               | L   | H    | H    | H   | X          | NOP           | Continue burst to end                         |
|               | L   | H    | H    | L   | X          | BST           | Terminate burst                               |
|               | L   | H    | L    | H   | BA, CA, AP | READ/READAP   | Term burst, new read:optional AP <sup>8</sup> |
|               | L   | H    | L    | L   | BA, CA, AP | WRITE/WRITEAP | ILLEGAL                                       |
|               | L   | L    | H    | H   | BA, RA     | ACT           | ILLEGAL <sup>4</sup>                          |
| WRITE         | L   | L    | H    | L   | BA, AP     | PRE/PALL      | Term burst, precharge                         |
|               | L   | L    | L    | H   | X          | AREF/SREF     | ILLEGAL <sup>11</sup>                         |
|               | L   | L    | L    | L   | OPCODE     | MRS           | ILLEGAL <sup>11</sup>                         |
|               | H   | X    | X    | X   | X          | DSEL          | Continue burst to end                         |
|               | L   | H    | H    | H   | X          | NOP           | Continue burst to end                         |
| WRITE         | L   | H    | H    | L   | X          | BST           | ILLEGAL <sup>4</sup>                          |
|               | L   | H    | L    | H   | BA, CA, AP | READ/READAP   | Term burst, new read:optional AP <sup>8</sup> |
| WRITE         | L   | H    | L    | L   | BA, CA, AP | WRITE/WRITEAP | Term burst, new write:optional AP             |

**OPERATION COMMAND TRUTH TABLE - II**

| Current State            | /CS | /RAS | /CAS | /WE | Address    | Command       | Action                   |
|--------------------------|-----|------|------|-----|------------|---------------|--------------------------|
| WRITE                    | L   | L    | H    | H   | BA, RA     | ACT           | ILLEGAL <sup>4</sup>     |
|                          | L   | L    | H    | L   | BA, AP     | PRE/PALL      | Term burst, precharge    |
|                          | L   | L    | L    | H   | X          | AREF/SREF     | ILLEGAL <sup>11</sup>    |
|                          | L   | L    | L    | L   | OPCODE     | MRS           | ILLEGAL <sup>11</sup>    |
| READ WITH AUTOPRE-CHARGE | H   | X    | X    | X   | X          | DSEL          | Continue burst to end    |
|                          | L   | H    | H    | H   | X          | NOP           | Continue burst to end    |
|                          | L   | H    | H    | L   | X          | BST           | ILLEGAL                  |
|                          | L   | H    | L    | H   | BA, CA, AP | READ/READAP   | ILLEGAL <sup>10</sup>    |
|                          | L   | H    | L    | L   | BA, CA, AP | WRITE/WRITEAP | ILLEGAL <sup>10</sup>    |
|                          | L   | L    | H    | H   | BA, RA     | ACT           | ILLEGAL <sup>4,10</sup>  |
|                          | L   | L    | H    | L   | BA, AP     | PRE/PALL      | ILLEGAL <sup>4,10</sup>  |
|                          | L   | L    | L    | H   | X          | AREF/SREF     | ILLEGAL <sup>11</sup>    |
| WRITE AUTOPRE-CHARGE     | H   | X    | X    | X   | X          | DSEL          | Continue burst to end    |
|                          | L   | H    | H    | H   | X          | NOP           | Continue burst to end    |
|                          | L   | H    | H    | L   | X          | BST           | ILLEGAL                  |
|                          | L   | H    | L    | H   | BA, CA, AP | READ/READAP   | ILLEGAL <sup>10</sup>    |
|                          | L   | H    | L    | L   | BA, CA, AP | WRITE/WRITEAP | ILLEGAL <sup>10</sup>    |
|                          | L   | L    | H    | H   | BA, RA     | ACT           | ILLEGAL <sup>4,10</sup>  |
|                          | L   | L    | H    | L   | BA, AP     | PRE/PALL      | ILLEGAL <sup>4,10</sup>  |
|                          | L   | L    | L    | H   | X          | AREF/SREF     | ILLEGAL <sup>11</sup>    |
| PRE-CHARGE               | H   | X    | X    | X   | X          | DSEL          | NOP-Enter IDLE after tRP |
|                          | L   | H    | H    | H   | X          | NOP           | NOP-Enter IDLE after tRP |
|                          | L   | H    | H    | L   | X          | BST           | ILLEGAL <sup>4</sup>     |
|                          | L   | H    | L    | H   | BA, CA, AP | READ/READAP   | ILLEGAL <sup>4,10</sup>  |
|                          | L   | H    | L    | L   | BA, CA, AP | WRITE/WRITEAP | ILLEGAL <sup>4,10</sup>  |
|                          | L   | L    | H    | H   | BA, RA     | ACT           | ILLEGAL <sup>4,10</sup>  |
|                          | L   | L    | H    | L   | BA, AP     | PRE/PALL      | NOP-Enter IDLE after tRP |
|                          | L   | L    | L    | H   | X          | AREF/SREF     | ILLEGAL <sup>11</sup>    |
|                          | L   | L    | L    | L   | OPCODE     | MRS           | ILLEGAL <sup>11</sup>    |

**OPERATION COMMAND TRUTH TABLE - III**

| Current State                        | /CS | /RAS | /CAS | /WE | Address    | Command       | Action                           |
|--------------------------------------|-----|------|------|-----|------------|---------------|----------------------------------|
| ROW ACTIVATING                       | H   | X    | X    | X   | X          | DSEL          | NOP - Enter ROW ACT after tRCD   |
|                                      | L   | H    | H    | H   | X          | NOP           | NOP - Enter ROW ACT after tRCD   |
|                                      | L   | H    | H    | L   | X          | BST           | ILLEGAL <sup>4</sup>             |
|                                      | L   | H    | L    | H   | BA, CA, AP | READ/READAP   | ILLEGAL <sup>4,10</sup>          |
|                                      | L   | H    | L    | L   | BA, CA, AP | WRITE/WRITEAP | ILLEGAL <sup>4,10</sup>          |
|                                      | L   | L    | H    | H   | BA, RA     | ACT           | ILLEGAL <sup>4,9,10</sup>        |
|                                      | L   | L    | H    | L   | BA, AP     | PRE/PALL      | ILLEGAL <sup>4,10</sup>          |
|                                      | L   | L    | L    | H   | X          | AREF/SREF     | ILLEGAL <sup>11</sup>            |
|                                      | L   | L    | L    | L   | OPCODE     | MRS           | ILLEGAL <sup>11</sup>            |
| WRITE RECOVERING                     | H   | X    | X    | X   | X          | DSEL          | NOP - Enter ROW ACT after tWR    |
|                                      | L   | H    | H    | H   | X          | NOP           | NOP - Enter ROW ACT after tWR    |
|                                      | L   | H    | H    | L   | X          | BST           | ILLEGAL <sup>4</sup>             |
|                                      | L   | H    | L    | H   | BA, CA, AP | READ/READAP   | ILLEGAL                          |
|                                      | L   | H    | L    | L   | BA, CA, AP | WRITE/WRITEAP | ILLEGAL                          |
|                                      | L   | L    | H    | H   | BA, RA     | ACT           | ILLEGAL <sup>4,10</sup>          |
|                                      | L   | L    | H    | L   | BA, AP     | PRE/PALL      | ILLEGAL <sup>4,11</sup>          |
|                                      | L   | L    | L    | H   | X          | AREF/SREF     | ILLEGAL <sup>11</sup>            |
|                                      | L   | L    | L    | L   | OPCODE     | MRS           | ILLEGAL <sup>11</sup>            |
| WRITE RECOVERING WITH AUTOPRE-CHARGE | H   | X    | X    | X   | X          | DSEL          | NOP - Enter precharge after tDPL |
|                                      | L   | H    | H    | H   | X          | NOP           | NOP - Enter precharge after tDPL |
|                                      | L   | H    | H    | L   | X          | BST           | ILLEGAL <sup>4</sup>             |
|                                      | L   | H    | L    | H   | BA, CA, AP | READ/READAP   | ILLEGAL <sup>4,8,10</sup>        |
|                                      | L   | H    | L    | L   | BA, CA, AP | WRITE/WRITEAP | ILLEGAL <sup>4,10</sup>          |
|                                      | L   | L    | H    | H   | BA, RA     | ACT           | ILLEGAL <sup>4,10</sup>          |
|                                      | L   | L    | H    | L   | BA, AP     | PRE/PALL      | ILLEGAL <sup>4,11</sup>          |
|                                      | L   | L    | L    | H   | X          | AREF/SREF     | ILLEGAL <sup>11</sup>            |
|                                      | L   | L    | L    | L   | OPCODE     | MRS           | ILLEGAL <sup>11</sup>            |
| REFRESHING                           | H   | X    | X    | X   | X          | DSEL          | NOP - Enter IDLE after tRC       |
|                                      | L   | H    | H    | H   | X          | NOP           | NOP - Enter IDLE after tRC       |
|                                      | L   | H    | H    | L   | X          | BST           | ILLEGAL <sup>11</sup>            |
|                                      | L   | H    | L    | H   | BA, CA, AP | READ/READAP   | ILLEGAL <sup>11</sup>            |

**OPERATION COMMAND TRUTH TABLE - IV**

| Current State           | /CS | /RAS | /CAS | /WE    | Address    | Command               | Action                      |
|-------------------------|-----|------|------|--------|------------|-----------------------|-----------------------------|
| WRITE                   | L   | H    | L    | L      | BA, CA, AP | WRITE/WRITEAP         | ILLEGAL <sup>11</sup>       |
|                         | L   | L    | H    | H      | BA, RA     | ACT                   | ILLEGAL <sup>11</sup>       |
|                         | L   | L    | H    | L      | BA, AP     | PRE/PALL              | ILLEGAL <sup>11</sup>       |
|                         | L   | L    | L    | H      | X          | AREF/SREF             | ILLEGAL <sup>11</sup>       |
|                         | L   | L    | L    | L      | OPCODE     | MRS                   | ILLEGAL <sup>11</sup>       |
| MODE REGISTER ACCESSING | H   | X    | X    | X      | X          | DSEL                  | NOP - Enter IDLE after tMRD |
|                         | L   | H    | H    | H      | X          | NOP                   | NOP - Enter IDLE after tMRD |
|                         | L   | H    | H    | L      | X          | BST                   | ILLEGAL <sup>11</sup>       |
|                         | L   | H    | L    | H      | BA, CA, AP | READ/READAP           | ILLEGAL <sup>11</sup>       |
|                         | L   | H    | L    | L      | BA, CA, AP | WRITE/WRITEAP         | ILLEGAL <sup>11</sup>       |
|                         | L   | L    | H    | H      | BA, RA     | ACT                   | ILLEGAL <sup>11</sup>       |
|                         | L   | L    | H    | L      | BA, AP     | PRE/PALL              | ILLEGAL <sup>11</sup>       |
|                         | L   | L    | L    | H      | X          | AREF/SREF             | ILLEGAL <sup>11</sup>       |
| L                       | L   | L    | L    | OPCODE | MRS        | ILLEGAL <sup>11</sup> |                             |

**Note :**

1. H - Logic High Level, L - Logic Low Level, X - Don't Care, V - Valid Data Input, BA - Bank Address, AP - AutoPrecharge Address, CA - Column Address, RA - Row Address, NOP - NO Operation.
2. All entries assume that CKE was active(high level) during the preceding clock cycle.
3. If both banks are idle and CKE is inactive(low level), then in power down mode.
4. Illegal to bank in specified state. Function may be legal in the bank indicated by Bank Address(BA) depending on the state of that bank.
5. If both banks are idle and CKE is inactive(low level), then self refresh mode.
6. Illegal if tRCD is not met.
7. Illegal if tRAS is not met.
8. Must satisfy bus contention, bus turn around, and/or write recovery requirements.
9. Illegal if tRRD is not met.
10. Illegal for single bank, but legal for other banks in multi-bank devices.
11. Illegal for all banks.

**CKE FUNCTION TRUTH TABLE**

| Current State               | CKEn-1 | CKEn | /CS | /RAS | /CAS | /WE | /ADD | Action                                    |
|-----------------------------|--------|------|-----|------|------|-----|------|---|
| SELF REFRESH <sup>1</sup>   | H      | X    | X   | X    | X    | X   | X    | INVALID                                   |
|                             | L      | H    | H   | X    | X    | X   | X    | Exit self refresh, enter idle after tSREX |
|                             | L      | H    | L   | H    | H    | H   | X    | Exit self refresh, enter idle after tSREX |
|                             | L      | H    | L   | H    | H    | L   | X    | ILLEGAL                                   |
|                             | L      | H    | L   | H    | L    | X   | X    | ILLEGAL                                   |
|                             | L      | H    | L   | L    | X    | X   | X    | ILLEGAL                                   |
|                             | L      | L    | X   | X    | X    | X   | X    | NOP, continue self refresh                |
| POWER DOWN <sup>2</sup>     | H      | X    | X   | X    | X    | X   | X    | INVALID                                   |
|                             | L      | H    | H   | X    | X    | X   | X    | Exit power down, enter idle               |
|                             | L      | H    | L   | H    | H    | H   | X    | Exit power down, enter idle               |
|                             | L      | H    | L   | H    | H    | L   | X    | ILLEGAL                                   |
|                             | L      | H    | L   | H    | L    | X   | X    | ILLEGAL                                   |
|                             | L      | H    | L   | L    | X    | X   | X    | ILLEGAL                                   |
|                             | L      | L    | X   | X    | X    | X   | X    | NOP, continue power down mode             |
| ALL BANKS IDLE <sup>4</sup> | H      | H    | X   | X    | X    | X   | X    | See operation command truth table         |
|                             | H      | L    | L   | L    | L    | H   | X    | Enter self refresh                        |
|                             | H      | L    | H   | X    | X    | X   | X    | Exit power down                           |
|                             | H      | L    | L   | H    | H    | H   | X    | Exit power down                           |
|                             | H      | L    | L   | H    | H    | L   | X    | ILLEGAL                                   |
|                             | H      | L    | L   | H    | L    | X   | X    | ILLEGAL                                   |
|                             | H      | L    | L   | L    | H    | X   | X    | ILLEGAL                                   |
|                             | H      | L    | L   | L    | L    | L   | X    | ILLEGAL                                   |
|                             | L      | L    | X   | X    | X    | X   | X    | NOP                                       |
| ANY STATE OTHER THAN ABOVE  | H      | H    | X   | X    | X    | X   | X    | See operation command truth table         |
|                             | H      | L    | X   | X    | X    | X   | X    | ILLEGAL <sup>5</sup>                      |
|                             | L      | H    | X   | X    | X    | X   | X    | INVALID                                   |
|                             | L      | L    | X   | X    | X    | X   | X    | INVALID                                   |

**Note :**

When CKE=L, all DQ and DQS must be in Hi-Z state.

1. CKE and /CS must be kept high for a minimum of 200 stable input clocks before issuing any command.
2. All command can be stored after 2 clocks from low to high transition of CKE.
3. Illegal if CK is suspended or stopped during the power down mode.
4. Self refresh can be entered only from the all banks idle state.
5. Disabling CK may cause malfunction of any bank which is in active state.

**SIMPLIFIED STATE DIAGRAM**

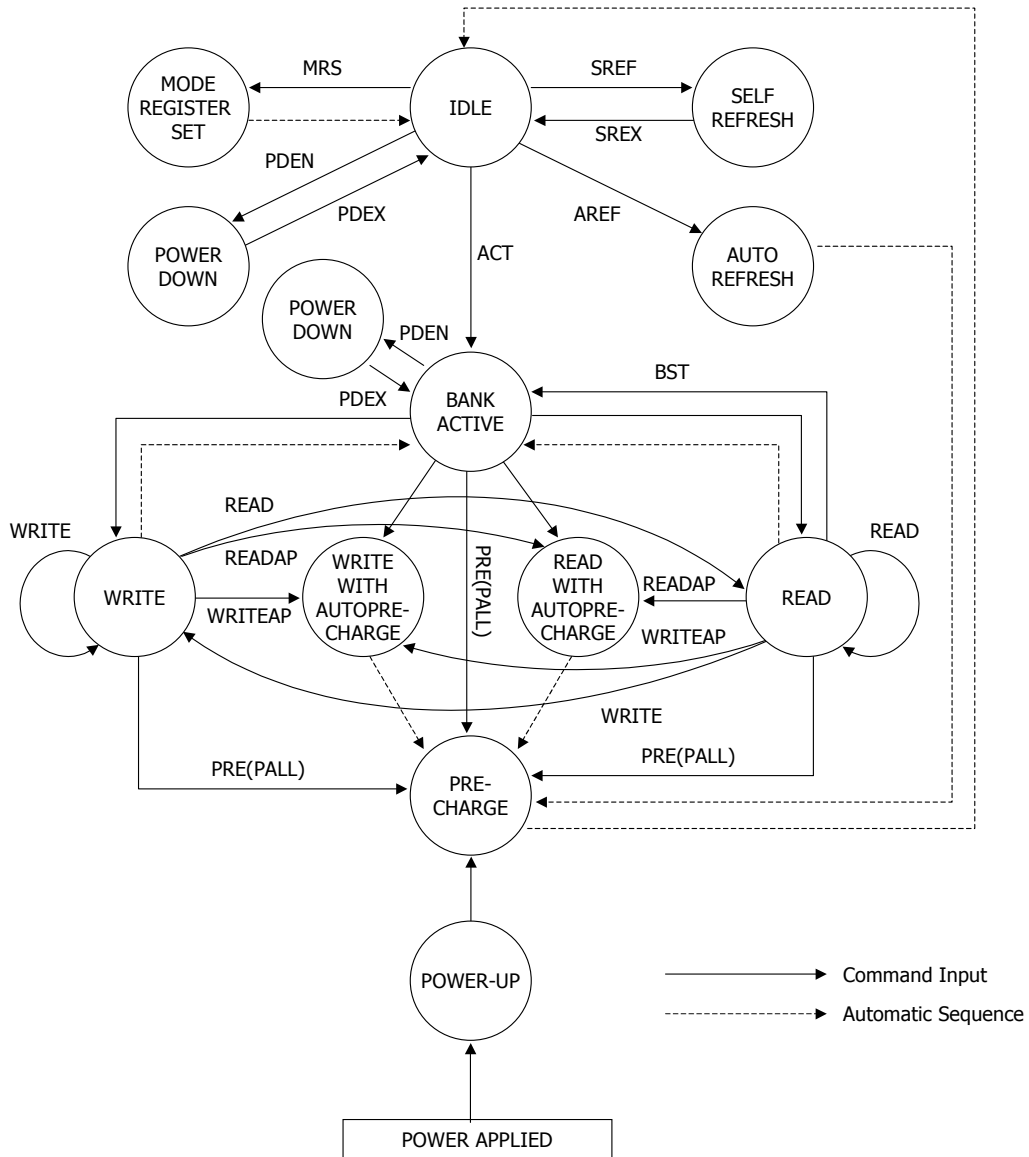

**POWER-UP SEQUENCE AND DEVICE INITIALIZATION**

DDR SDRAMs must be powered up and initialized in a predefined manner. Operational procedures other than those specified may result in undefined operation. Except for CKE, inputs are not recognized as valid until after VREF is applied. CKE is an SSTL\_2 input, but will detect an LVCMOS LOW level after VDD is applied. Maintaining an LVCMOS LOW level on CKE during power-up is required to guarantee that the DQ and DQS outputs will be in the High-Z state, where they will remain until driven in normal operation (by a read access). After all power supply and reference voltages are stable, and the clock is stable, the DDR SDRAM requires a 200us delay prior to applying an executable command.

Once the 200us delay has been satisfied, a DESELECT or NOP command should be applied, and CKE should be brought HIGH. Following the NOP command, a PRECHARGE ALL command should be applied. Next a EXTENDED MODE REGISTER SET command should be issued for the Extended Mode Register, to enable the DLL, then a MODE REGISTER SET command should be issued for the Mode Register, to reset the DLL, and to program the operating parameters. After the DLL reset, tXSRD(DLL locking time) should be satisfied for read command. After the Mode Register set command, a PRECHARGE ALL command should be applied, placing the device in the all banks idle state.

Once in the idle state, two AUTO REFRESH cycles must be performed. Additionally, a MODE REGISTER SET command for the Mode Register, with the reset DLL bit deactivated low (i.e. to program operating parameters without resetting the DLL) must be performed. Following these cycles, the DDR SDRAM is ready for normal operation.

1. Apply power - VDD, VDDQ, VTT, VREF in the following power up sequencing and attempt to maintain CKE at LVCMOS low state. (All the other input pins may be undefined).

No power sequencing is specified during power up or power down given the following criteria :

- VDD and VDDQ are driven from a single power converter output.
- VTT is limited to 1.44V (reflecting VDDQ(max)/2 + 50mV VREF variation + 40mV VTT variation).
- VREF tracks VDDQ/2.
- A minimum resistance of 42 ohms (22 ohm series resistor + 22 ohm parallel resistor - 5% tolerance) limits the input current from the VTT supply into any pin.

If the above criteria cannot be met by the system design, then the following sequencing and voltage relationship must be adhered to during power up :

| Voltage description | Sequencing         | Voltage relationship to avoid latch-up |
|---------------------|--------------------|--|
| VDDQ                | After or with VDD  | < VDD + 0.3V                           |
| VTT                 | After or with VDDQ | < VDDQ + 0.3V                          |
| VREF                | After or with VDDQ | < VDDQ + 0.3V                          |

2. Start clock and maintain stable clock for a minimum of 200usec.
3. After stable power and clock, apply NOP condition and take CKE high.
4. Issue Extended Mode Register Set (EMRS) to enable DLL.
5. Issue Mode Register Set (MRS) to reset DLL and set device to idle state with bit A8=high. (An additional 200 cycles(tXSRD) of clock are required for locking DLL)
6. Issue Precharge commands for all banks of the device.

7. Issue 2 or more Auto Refresh commands.
8. Issue a Mode Register Set command to initialize the mode register with bit A8 = Low.

**Power-Up Sequence**

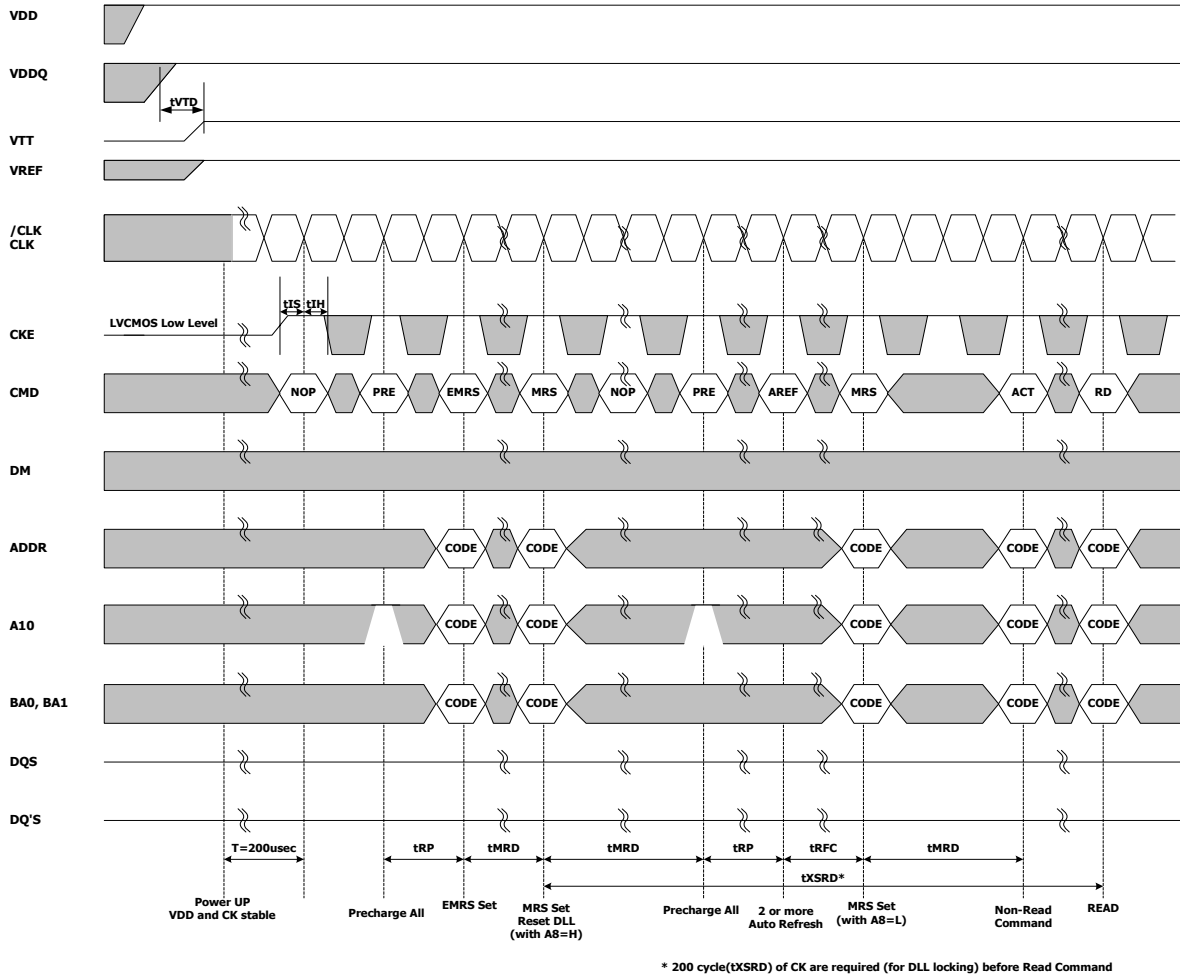



---

## MODE REGISTER SET (MRS)

The mode register is used to store the various operating modes such as /CAS latency, addressing mode, burst length, burst type, test mode, DLL reset. The mode register is program via MRS command. This command is issued by the low signals of /RAS, /CAS, /CS, /WE and BA0. This command can be issued only when all banks are in idle state and CKE must be high at least one cycle before the Mode Register Set Command can be issued. Two cycles are required to write the data in mode register. During the the MRS cycle, any command cannot be issued. Once mode register field is determined, the information will be held until resetted by another MRS command.

| BA1 | BA0 | A12            | A11 | A10 | A9 | A8 | A7          | A6 | A5 | A4 | A3           | A2 | A1 | A0 |
|-----|-----|----------------|-----|-----|----|----|-------------|----|----|----|--------------|----|----|----|
| 0   | 0   | Operating Mode |     |     |    |    | CAS Latency |    |    | BT | Burst Length |    |    |    |

| BA0 | MRS Type |
|-----|----------|
| 0   | MRS      |
| 1   | EMRS     |

| A6 | A5 | A4 | CAS Latency |
|----|----|----|-------------|
| 0  | 0  | 0  | Reserved    |
| 0  | 0  | 1  | Reserved    |
| 0  | 1  | 0  | 2           |
| 0  | 1  | 1  | 3           |
| 1  | 0  | 0  | Reserved    |
| 1  | 0  | 1  | 1.5         |
| 1  | 1  | 0  | 2.5         |
| 1  | 1  | 1  | Reserved    |

| A3 | Burst Type |
|----|------------|
| 0  | Sequential |
| 1  | Interleave |

| A12~A9 | A8 | A7 | A6~A0 | Operating Mode              |
|--------|----|----|-------|-----------------------------|
| 0      | 0  | 0  | Valid | Normal Operation            |
| 0      | 1  | 0  | Valid | Normal Operation/ Reset DLL |
| 0      | 0  | 1  | VS    | Vendor specific Test Mode   |
| -      | -  | -  |       | All other states reserved   |

| A2 | A1 | A0 | Burst Length |            |
|----|----|----|--------------|------------|
|    |    |    | Sequential   | Interleave |
| 0  | 0  | 0  | Reserved     | Reserved   |
| 0  | 0  | 1  | 2            | 2          |
| 0  | 1  | 0  | 4            | 4          |
| 0  | 1  | 1  | 8            | 8          |
| 1  | 0  | 0  | Reserved     | Reserved   |
| 1  | 0  | 1  | Reserved     | Reserved   |
| 1  | 1  | 0  | Reserved     | Reserved   |
| 1  | 1  | 1  | Reserved     | Reserved   |

**BURST DEFINITION**

| Burst Length | Starting Address (A2,A1,A0) | Sequential             | Interleave             |
|--------------|-----------------------------|------------------------|------------------------|
| 2            | XX0                         | 0, 1                   | 0, 1                   |
|              | XX1                         | 1, 0                   | 1, 0                   |
| 4            | X00                         | 0, 1, 2, 3             | 0, 1, 2, 3             |
|              | X01                         | 1, 2, 3, 0             | 1, 0, 3, 2             |
|              | X10                         | 2, 3, 0, 1             | 2, 3, 0, 1             |
|              | X11                         | 3, 0, 1, 2             | 3, 2, 1, 0             |
| 8            | 000                         | 0, 1, 2, 3, 4, 5, 6, 7 | 0, 1, 2, 3, 4, 5, 6, 7 |
|              | 001                         | 1, 2, 3, 4, 5, 6, 7, 0 | 1, 0, 3, 2, 5, 4, 7, 6 |
|              | 010                         | 2, 3, 4, 5, 6, 7, 0, 1 | 2, 3, 0, 1, 6, 7, 4, 5 |
|              | 011                         | 3, 4, 5, 6, 7, 0, 1, 2 | 3, 2, 1, 0, 7, 6, 5, 4 |
|              | 100                         | 4, 5, 6, 7, 0, 1, 2, 3 | 4, 5, 6, 7, 0, 1, 2, 3 |
|              | 101                         | 5, 6, 7, 0, 1, 2, 3, 4 | 5, 4, 7, 6, 1, 0, 3, 2 |
|              | 110                         | 6, 7, 0, 1, 2, 3, 4, 5 | 6, 7, 4, 5, 2, 3, 0, 1 |
|              | 111                         | 7, 0, 1, 2, 3, 4, 5, 6 | 7, 6, 5, 4, 3, 2, 1, 0 |

**BURST LENGTH & TYPE**

Read and write accesses to the DDR SDRAM are burst oriented, with the burst length being programmable. The burst length determines the maximum number of column locations that can be accessed for a given Read or Write command. Burst lengths of 2, 4 or 8 locations are available for both the sequential and the interleaved burst types. Reserved states should not be used, as unknown operation or incompatibility with future versions may result.

When a Read or Write command is issued, a block of columns equal to the burst length is effectively selected. All accesses for that burst take place within this block, meaning that the burst wraps within the block if a boundary is reached. The block is uniquely selected by A1-Ai when the burst length is set to two, by A2-Ai when the burst length is set to four and by A3-Ai when the burst length is set to eight (where Ai is the most significant column address bit for a given configuration). The remaining (least significant) address bit(s) is (are) used to select the starting location within the block. The programmed burst length applies to both Read and Write bursts.

Accesses within a given burst may be programmed to be either sequential or interleaved; this is referred to as the burst type and is selected via bit A3. The ordering of accesses within a burst is determined by the burst length, the burst type and the starting column address, as shown in Burst Definitionon Table

## CAS LATENCY

The Read latency or CAS latency is the delay in clock cycles between the registration of a Read command and the availability of the first burst of output data. The latency can be programmed 3 or 4 clocks.

If a Read command is registered at clock edge  $n$ , and the latency is  $m$  clocks, the data is available nominally coincident with clock edge  $n + m$ .

Reserved states should not be used as unknown operation or incompatibility with future versions may result.

## DLL RESET

The DLL must be enabled for normal operation. DLL enable is required during power up initialization, and upon returning to normal operation after having disabled the DLL for the purpose of debug or evaluation. The DLL is automatically disabled when entering self refresh operation and is automatically re-enabled upon exit of self refresh operation. Any time the DLL is enabled, 200 clock cycles must occur to allow time for the internal clock to lock to the externally applied clock before an any command can be issued.

## OUTPUT DRIVER IMPEDANCE CONTROL

The HY5DV281622D supports Full, Half strength driver and Matched impedance driver, intended for lighter load and/or point-to-point environments. The Full drive strength for all output is specified to be SSTL\_2, CLASS II. Half strength driver is to define about 50% of Full drive strength and Matched impedance driver, about 30% of Full drive strength.

**EXTENDED MODE REGISTER SET (EMRS)**

The Extended Mode Register controls functions beyond those controlled by the Mode Register; these additional functions include DLL enable/disable, output driver strength selection(optional). These functions are controlled via the bits shown below. The Extended Mode Register is programmed via the Mode Register Set command ( BA0=1 and BA1=0) and will retain the stored information until it is programmed again or the device loses power.

The Extended Mode Register must be loaded when all banks are idle and no bursts are in progress, and the controller must wait the specified time before initiating any subsequent operation. Violating either of these requirements will result in unspecified operation.

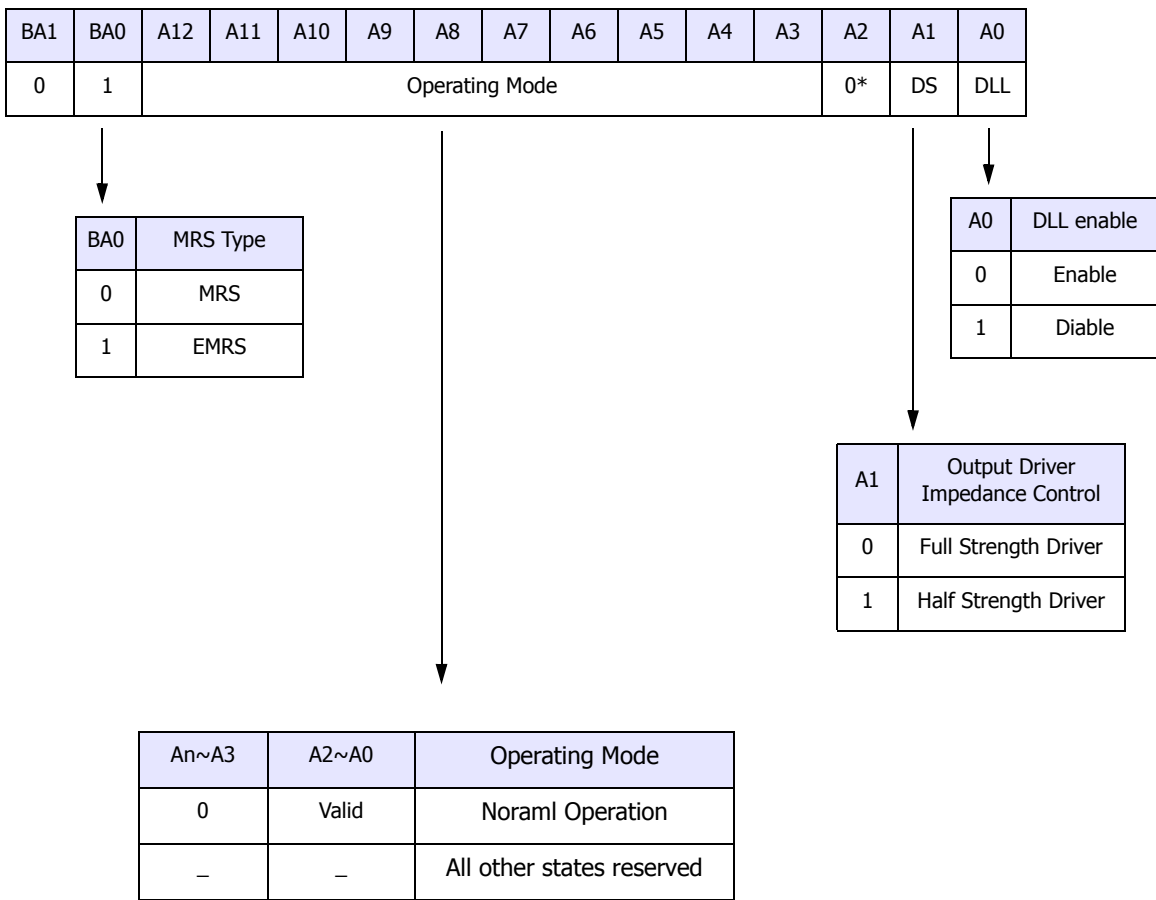

\* This part do not support/QFC function, A2 must be programmed to Zero.

**ABSOLUTE MAXIMUM RATINGS**

| Parameter                          | Symbol    | Rating     | Unit     |
|------------------------------------|-----------|------------|----------|
| Ambient Temperature                | TA        | 0 ~ 70     | °C       |
| Storage Temperature                | TSTG      | -55 ~ 125  | °C       |
| Voltage on Any Pin relative to VSS | VIN, VOUT | -0.5 ~ 3.6 | V        |
| Voltage on VDD relative to VSS     | VDD       | -0.5 ~ 3.6 | V        |
| Voltage on VDDQ relative to VSS    | VDDQ      | -0.5 ~ 3.6 | V        |
| Output Short Circuit Current       | IOS       | 50         | mA       |
| Power Dissipation                  | PD        | 1          | W        |
| Soldering Temperature · Time       | TSOLDER   | 260 · 10   | °C · sec |

**Note :** Operation at above absolute maximum rating can adversely affect device reliability

**DC OPERATING CONDITIONS** (TA=0 to 70°C, Voltage referenced to VSS = 0V)

| Parameter                                      | Symbol    | Min         | Typ.       | Max         | Unit          | Note |
|--|-----------|-------------|------------|-------------|---------------|------|
| Power Supply Voltage                           | VDD       | 3.15        | 3.3        | 3.45        | V             |      |
| Power Supply Voltage                           | VDD       | 3.15        | 3.3        | 3.65        | V             | 4    |
| Power Supply Voltage                           | VDDQ      | 2.375       | 2.5        | 2.625       | V             | 1    |
| Power Supply Voltage                           | VDDQ      | 2.375       | 2.5        | 3.15        | V             | 1,4  |
| Input High Voltage                             | VIH       | VREF + 0.15 | -          | VDDQ + 0.3  | V             |      |
| Input Low Voltage                              | VIL       | -0.3        | -          | VREF - 0.15 | V             | 2    |
| Termination Voltage                            | VTT       | VREF - 0.04 | VREF       | VREF + 0.04 | V             |      |
| Reference Voltage                              | VREF      | 0.49*VDDQ   | 0.5*VDDQ   | 0.51*VDDQ   | V             | 3    |
| Input Voltage Level, CK and CK inputs          | VIN(DC)   | -0.3        | VDDQ+0.3   | V           |               |      |
| Input Differential Voltage, CK and CK inputs   | VID(DC)   | 0.36        | VDDQ+0.6   | V           | 4             |      |
| V-I Matching: Pullup to Pulldown Current Ratio | VI(RATIO) | 0.71        | 1.4        | -           | 5             |      |
| Input Leakage Current                          | ILI       | -2          | 2          | µA          | 6             |      |
| Output Leakage Current                         | ILO       | -5          | 5          | µA          |               |      |
| Output High Voltage                            | VOH       | VTT + 0.76  | -          | V           | IOL = -15.2mA |      |
| Output Low Voltage                             | VOL       | -           | VTT - 0.76 | V           | IOL = +15.2mA |      |

**Note :**

- VDDQ must not exceed the level of VDD.
- VIL (min) is acceptable -1.5V AC pulse width with  $\leq 5$ ns of duration.
- VREF is expected to be equal to 0.5\*VDDQ of the transmitting device, and to track variations in the dc level of the same.  
Peak to peak noise on VREF may not exceed  $\pm 2\%$  of the dc value.
- Supports 300/275MHz
- VID is the magnitude of the difference between the input level on CK and the input level on /CK.
- The ratio of the pullup current to the pulldown current is specified for the same temperature and voltage, over the entire temperature and voltage range, for device drain to source voltages from 0.25V to 1.0V. For a given output, it represents the maximum difference between pullup and pulldown drivers due to process variation. The full variation in the ratio of the maximum to minimum pullup and pulldown current will not exceed 1/7 for device drain to source voltages from 0.1 to 1.0.
- VIN=0 to VDD, All other pins are not tested under VIN =0V. 2. DOUT is disabled, VOUT=0 to VDDQ

**DC CHARACTERISTICS I** (TA=0 to 70oC, Voltage referenced to VSS = 0V)

| Parameter              | Symbol | Min.       | Max        | Unit | Note          |
|------------------------|--------|------------|------------|------|---------------|
| Input Leakage Current  | ILI    | -5         | 5          | uA   | 1             |
| Output Leakage Current | ILO    | -5         | 5          | uA   | 2             |
| Output High Voltage    | VOH    | VTT + 0.76 | -          | V    | IOH = -15.2mA |
| Output Low Voltage     | VOL    | -          | VTT - 0.76 | V    | IOL = +15.2mA |

**Note** : 1. VIN = 0 to 3.6V, All other pins are not tested under VIN = 0V. 2. DOUT is disabled, VOUT = 0 to 2.7V

**DC CHARACTERISTICS II** (TA=0 to 70°C, Voltage referenced to VSS = 0V)

| Parameter                               | Symbol | Test Condition  | Speed |     |     |     |     | Unit | Note |
|---|--------|---|-------|-----|-----|-----|-----|------|------|
|   |        |   | 33    | 36  | 4   | 5   | 6   |      |      |
| Operating Current                       | IDD0   | One bank; Active - Precharge; tRC=tRC(min); tCK=tCK(min); DQ,DM and DQS inputs changing twice per clock cycle; address and control inputs changing once per clock cycle                           | 150   | 140 | 130 | 120 | 100 | mA   |      |
| Operating Current                       | IDD1   | One bank; Active - Read - Precharge; Burst=2; tRC=tRC(min); tCK=tCK(min); address and control inputs changing once per clock cycle; IOU=0mA   | 170   | 150 | 140 | 130 | 110 | mA   |      |
| Precharge Power Down Standby Current    | IDD2P  | All banks idle; Power down mode; CKE=Low, tCK=tCK(min)  | 20    |     |     |     |     | mA   |      |
| Idle Standby Current                    | IDD2F  | /CS=High, All banks idle; tCK=tCK(min); CKE=High; address and control inputs changing once per clock cycle. VIN=VREF for DQ, DQS and DM   | 90    | 80  | 70  | 60  | 50  | mA   |      |
| Active Power Down Standby Current       | IDD3P  | One bank active; Power down mode ; CKE=Low, tCK=tCK(min)  | 20    |     |     |     |     | mA   |      |
| Active Standby Current                  | IDD3N  | /CS=HIGH; CKE=HIGH; One bank; Active-Precharge; tRC=tRAS(max); tCK=tCK(min); DQ, DM and DQS inputs changing twice per clock cycle; Address and other control inputs changing once per clock cycle | 90    | 80  | 70  | 60  | 50  | mA   |      |
| Operating Current                       | IDD4R  | Burst=2; Reads; Continuous burst; One bank active; Address and control inputs changing once per clock cycle; tCK=tCK(min); IOU=0mA  | 250   | 230 | 210 | 180 | 160 | mA   |      |
| Operating Current                       | IDD4W  | Burst=2; Writes; Continuous burst; One bank active; Address and control inputs changing once per clock cycle; tCK=tCK(min); DQ, DM and DQS inputs changing twice per clock cycle                  | 210   | 190 | 170 | 150 | 140 | mA   |      |
| Auto Refresh Current                    | IDD5   | tRC=tRFC(min); All banks active   | 220   | 200 | 180 | 150 | 140 | mA   |      |
| Self Refresh Current                    | IDD6   | CKE=<0.2V; External clock on; tCK=tCK(min)  | 2     |     |     |     |     | mA   |      |
| Operating Current - Four Bank Operation | IDD7   | Four bank interleaving with BL=4  | 350   | 330 | 310 | 270 | 250 | mA   |      |



**AC OPERATING CONDITIONS** (TA=0 to 70°C, Voltage referenced to VSS = 0V)

| Parameter  | Symbol  | Min          | Max          | Unit | Note |
|--|---------|--------------|--------------|------|------|
| Input High (Logic 1) Voltage, DQ, DQS and DM signals | VIH(AC) | VREF + 0.35  |              | V    |      |
| Input Low (Logic 0) Voltage, DQ, DQS and DM signals  | VIL(AC) |              | VREF - 0.35  | V    |      |
| Input Differential Voltage, CK and /CK inputs        | VID(AC) | 0.7          | VDDQ + 0.6   | V    | 1    |
| Input Crossing Point Voltage, CK and /CK inputs      | VIX(AC) | 0.5*VDDQ-0.2 | 0.5*VDDQ+0.2 | V    | 2    |

**Note :**

1. VID is the magnitude of the difference between the input level on CK and the input on CK.
2. The value of VIX is expected to equal 0.5\*VDDQ of the transmitting device and must track variations in the DC level of the same.

**AC OPERATING TEST CONDITIONS** (TA=0 to 70°C, Voltage referenced to VSS = 0V)

| Parameter  | Value       | Unit |
|--|-------------|------|
| Reference Voltage  | VDDQ x 0.5  | V    |
| Termination Voltage                                      | VDDQ x 0.5  | V    |
| AC Input High Level Voltage (VIH, min)                   | VREF + 0.35 | V    |
| AC Input Low Level Voltage (VIL, max)                    | VREF - 0.35 | V    |
| Input Timing Measurement Reference Level Voltage         | VREF        | V    |
| Output Timing Measurement Reference Level Voltage        | VTT         | V    |
| Input Signal maximum peak swing                          | 1.5         | V    |
| Input minimum Signal Slew Rate                           | 1           | V/ns |
| Termination Resistor (RT)                                | 50          | Ω    |
| Series Resistor (RS)                                     | 25          | Ω    |
| Output Load Capacitance for Access Time Measurement (CL) | 30          | pF   |

### AC Overshoot/Undershoot Specification for Address and Control Pins

This specification is intended for devices with no clamp protection and is guaranteed by design

| Parameter  | Specification |            |
|--|---------------|------------|
|  | DDR333        | DDR200/266 |
| Maximum peak amplitude allowed for overshoot (See Figure 1):                                 | 1.5V          | 1.5V       |
| Maximum peak amplitude allowed for undershoot (See Figure 1):                                | 1.5V          | 1.5V       |
| The area between the overshoot signal and VDD must be less than or equal to (See Figure 1):  | 4.5V - ns     | 4.5V - ns  |
| The area between the undershoot signal and GND must be less than or equal to (See Figure 1): | 4.5V - ns     | 4.5V - ns  |

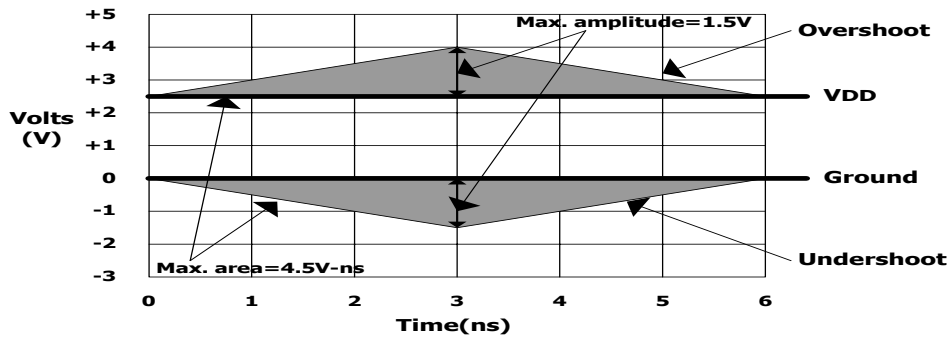

Figure 1: Address and Control AC Overshoot and Undershoot Definition

### Overshoot/Undershoot Specification for Data, Strobe, and Mask Pins

| Parameter  | Specification |            |
|--|---------------|------------|
|  | DDR333        | DDR200/266 |
| Maximum peak amplitude allowed for overshoot (See Figure 2):                                 | 1.2V          | 1.2V       |
| Maximum peak amplitude allowed for undershoot (See Figure 2):                                | 1.2V          | 1.2V       |
| The area between the overshoot signal and VDD must be less than or equal to (See Figure 2):  | 2.4V - ns     | 2.4V - ns  |
| The area between the undershoot signal and GND must be less than or equal to (See Figure 2): | 2.4V - ns     | 2.4V - ns  |

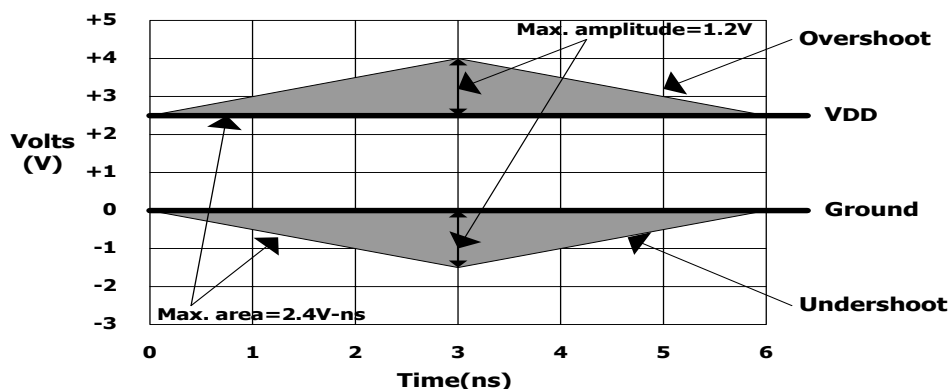

Figure 2: DQ/DM/DQS AC Overshoot and Undershoot Definition

**AC CHARACTERISTICS - I** (AC operating conditions unless otherwise noted)

| Parameter   | Symbol | 33            |      | 36            |      | 4             |      | 5             |      | 6             |      | Unit | Note |  |
|---|--------|---------------|------|---------------|------|---------------|------|---------------|------|---------------|------|------|------|--|
|   |        | Min           | Max  | Min           | Max  | Min           | Max  | Min           | Max  | Min           | Max  |      |      |  |
| Row Cycle Time  | tRC    | 18            | -    | 16            | -    | 15            | -    | 12            | -    | 11            | -    | CK   |      |  |
| Auto Refresh Row Cycle Time                                 | tRFC   | 22            | -    | 20            | -    | 18            | -    | 14            | -    | 12            | -    | CK   |      |  |
| Row Active Time   | tRAS   | 12            | 100K | 11            | 100K | 10            | 100K | 8             | 100K | 7             | 100K | CK   |      |  |
| Row Address to Column Address Delay                         | tRCDRD | 6             | -    | 5             | -    | 5             | -    | 4             | -    | 4             | -    | CK   |      |  |
|   | tRCDWT | 2             | -    | 2             | -    | 2             | -    | 2             | -    | 2             | -    | CK   |      |  |
| Row Active to Row Active Delay                              | tRRD   | 2             | -    | 2             | -    | 2             | -    | 2             | -    | 2             | -    | CK   |      |  |
| Column Address to Column Address Delay                      | tCCD   | 1             | -    | 1             | -    | 1             | -    | 1             | -    | 1             | -    | CK   |      |  |
| Row Precharge Time  | tRP    | 6             | -    | 5             | -    | 5             | -    | 4             | -    | 4             | -    | CK   |      |  |
| Last Data-In to Precharge Delay (Write Recovery Time : tWR) | tDPL   | 3             | -    | 3             | -    | 3             | -    | 3             | -    | 2             | -    | CK   |      |  |
| Last Data-In to Read Command                                | tDRL   | 2             | -    | 2             | -    | 2             | -    | 2             | -    | 2             | -    | CK   |      |  |
| Auto Precharge Write Recovery + Precharge Time              | tDAL   | 9             | -    | 8             | -    | 8             | -    | 7             | -    | 6             | -    | CK   |      |  |
| System Clock Cycle Time                                     | tCK    | CL = 4.0      | 3.3  | 6.0           | 3.6  | 6.0           | 4.0  | 6.0           | -    | -             | -    | -    | ns   |  |
|   |        | CL = 3.0      | -    | -             | -    | -             | 4.3  | 7.0           | 5.0  | 7.0           | 6.0  | 7.0  | ns   |  |
| Clock High Level Width                                      | tCH    | 0.45          | 0.55 | 0.45          | 0.55 | 0.45          | 0.55 | 0.45          | 0.55 | 0.45          | 0.55 | CK   |      |  |
| Clock Low Level Width                                       | tCL    | 0.45          | 0.55 | 0.45          | 0.55 | 0.45          | 0.55 | 0.45          | 0.55 | 0.45          | 0.55 | CK   |      |  |
| Data-Out edge to Clock edge Skew                            | tAC    | -0.7          | 0.7  | -0.7          | 0.7  | -0.7          | 0.7  | -0.7          | 0.7  | -0.75         | 0.75 | ns   |      |  |
| DQS-Out edge to Clock edge Skew                             | tDQSCK | -0.7          | 0.7  | -0.7          | 0.7  | -0.7          | 0.7  | -0.7          | 0.7  | -0.75         | 0.75 | ns   |      |  |
| DQS-Out edge to Data-Out edge Skew                          | tDQSQ  | -             | 0.4  | -             | 0.4  | -             | 0.4  | -             | 0.45 | -             | 0.5  | ns   |      |  |
| Data-Out hold time from DQS                                 | tQH    | tHPmin - tQHS | -    | tHPmin - tQHS | -    | tHPmin - tQHS | -    | tHPmin - tQHS | -    | tHPmin - tQHS | -    | ns   | 1, 6 |  |
| Clock Half Period   | tHP    | tCH/L min     | -    | tCH/L min     | -    | tCH/L min     | -    | tCH/L min     | -    | tCH/L min     | -    | ns   | 1, 5 |  |
| Data Hold Skew Factor                                       | tQHS   | -             | 0.4  | -             | 0.4  | -             | 0.4  | -             | 0.75 | -             | 0.75 | ns   | 6    |  |
| Input Setup Time  | tIS    | 0.9           | -    | 0.9           | -    | 0.9           | -    | 0.9           | -    | 0.9           | -    | ns   | 2    |  |
| Input Hold Time   | tIH    | 0.9           | -    | 0.9           | -    | 0.9           | -    | 0.9           | -    | 0.9           | -    | ns   | 2    |  |

| Parameter                                | Symbol | 33         |      | 36         |      | 4          |      | 5          |      | 6          |      | Unit | Note |
|--|--------|------------|------|------------|------|------------|------|------------|------|------------|------|------|------|
|  |        | Min        | Max  | Min        | Max  | Min        | Max  | Min        | Max  | Min        | Max  |      |      |
| Write DQS High Level Width               | tDQSH  | 0.4        | 0.6  | 0.4        | 0.6  | 0.4        | 0.6  | 0.4        | 0.6  | 0.4        | 0.6  | CK   |      |
| Write DQS Low Level Width                | tDQSL  | 0.4        | 0.6  | 0.4        | 0.6  | 0.4        | 0.6  | 0.4        | 0.6  | 0.4        | 0.6  | CK   |      |
| Clock to First Rising edge of DQS-In     | tDQSS  | 0.85       | 1.15 | 0.85       | 1.15 | 0.85       | 1.15 | 0.75       | 1.25 | 0.75       | 1.25 | CK   |      |
| Data-In Setup Time to DQS-In (DQ & DM)   | tDS    | 0.4        | -    | 0.4        | -    | 0.4        | -    | 0.5        | -    | 0.5        | -    | ns   | 3    |
| Data-In Hold Time to DQS-In (DQ & DM)    | tDH    | 0.4        | -    | 0.4        | -    | 0.4        | -    | 0.5        | -    | 0.5        | -    | ns   | 3    |
| Read DQS Preamble Time                   | trPRE  | 0.9        | 1.1  | 0.9        | 1.1  | 0.9        | 1.1  | 0.9        | 1.1  | 0.9        | 1.1  | CK   |      |
| Read DQS Postamble Time                  | trPST  | 0.4        | 0.6  | 0.4        | 0.6  | 0.4        | 0.6  | 0.4        | 0.6  | 0.4        | 0.6  | CK   |      |
| Write DQS Preamble Setup Time            | tWPRES | 0          | -    | 0          | -    | 0          | -    | 0          | -    | 0          | -    | ns   |      |
| Write DQS Preamble Hold Time             | tWPREH | 1.5        | -    | 1.5        | -    | 1.5        | -    | 1.5        | -    | 1.5        | -    | ns   |      |
| Write DQS Postamble Time                 | tWPST  | 0.4        | 0.6  | 0.4        | 0.6  | 0.4        | 0.6  | 0.4        | 0.6  | 0.4        | 0.6  | CK   |      |
| Mode Register Set Delay                  | tMRD   | 3          | -    | 3          | -    | 3          | -    | 2          | -    | 2          | -    | CK   |      |
| Exit Self Refresh to Any Execute Command | tXSC   | 200        | -    | 200        | -    | 200        | -    | 200        | -    | 200        | -    | CK   | 4    |
| Power Down Exit Time                     | tPDEX  | 1tCK + tIS | -    | 1tCK + tIS | -    | 1tCK + tIS | -    | 1tCK + tIS | -    | 1tCK + tIS | -    | CK   |      |
| Average Periodic Refresh Interval        | tREFI  | -          | 7.8  | -          | 7.8  | -          | 7.8  | -          | 7.8  | -          | 7.8  | us   |      |

**Note :**

1. This calculation accounts for tDQSQ(max), the pulse width distortion of on-chip circuit and jitter.
2. Data sampled at the rising edges of the clock : A0~A11, BA0~BA1, CKE, /CS, /RAS, /CAS, /WE.
3. Data latched at both rising and falling edges of Data Strobes(LDQS/UDQS) : DQ, LDM/UDM.
4. Minimum of 200 cycles of stable input clocks after Self Refresh Exit command, where CKE is held high, is required to complete Self Refresh Exit and lock the internal DLL circuit of DDR SDRAM.
5. Min (tCL, tCH) refers to the smaller of the actual clock low time and the actual clock high time as provided to the device (i.e. this value can be greater than the minimum specification limits for tCL and tCH).
6. tHP = minimum half clock period for any given cycle and is defined by clock high or clock low (tCH, tCL). tQHS consists of tDQSQmax, the pulse width distortion of on-chip clock circuits, data pin to pin skew and output pattern effects, and p-channel to n-channel variation of the output drivers.
7. DQS, DM and DQ input slew rate is specified to prevent double clocking of data and preserve setup and hold times. Signal transitions through the DC region must be monotonic.

**AC CHARACTERISTICS - II**

| Frequency      | CL | tRC | tRFC | tRAS | tRCDRD | tRCDWR | tRP | tDAL | Unit |
|----------------|----|-----|------|------|--------|--------|-----|------|------|
| 300MHz (3.3ns) | 4  | 18  | 22   | 12   | 6      | 2      | 6   | 9    | tCK  |
| 275MHz (3.6ns) | 4  | 16  | 20   | 11   | 5      | 2      | 5   | 8    | tCK  |
| 250MHz (4.0ns) | 4  | 15  | 18   | 10   | 5      | 2      | 5   | 8    | tCK  |
| 233MHz (4.3ns) | 3  | 15  | 18   | 10   | 5      | 2      | 5   | 8    | tCK  |
| 200MHz (5.0ns) | 3  | 12  | 14   | 8    | 4      | 2      | 4   | 7    | tCK  |
| 166MHz (6.0ns) | 3  | 11  | 12   | 7    | 4      | 2      | 4   | 6    | tCK  |

## CAPACITANCE (TA=25°C, f=1MHz )

| Parameter                  | Pin                        | Symbol | Min | Max | Unit |
|----------------------------|----------------------------|--------|-----|-----|------|
| Input Clock Capacitance    | CK, $\overline{\text{CK}}$ | CCK    | 2.0 | 3.0 | pF   |
| Input Capacitance          | All other input-only pins  | CIN    | 2.0 | 3.0 | pF   |
| Input / Output Capacitance | DQ, DQS, DM                | CIO    | 4.0 | 5.0 | pF   |

**Note :**

1. VDD = min. to max., VDDQ = 2.3V to 2.7V, VODC = VDDQ/2, VOpeak-to-peak = 0.2V
2. Pins not under test are tied to GND.
3. These values are guaranteed by design and are tested on a sample basis only.

## OUTPUT LOAD CIRCUIT

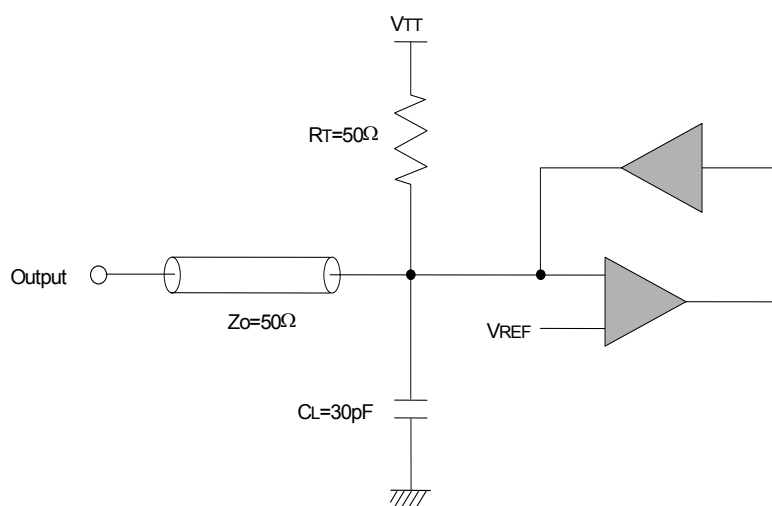

## PACKAGE INFORMATION

400mil 66pin Thin Small Outline Package

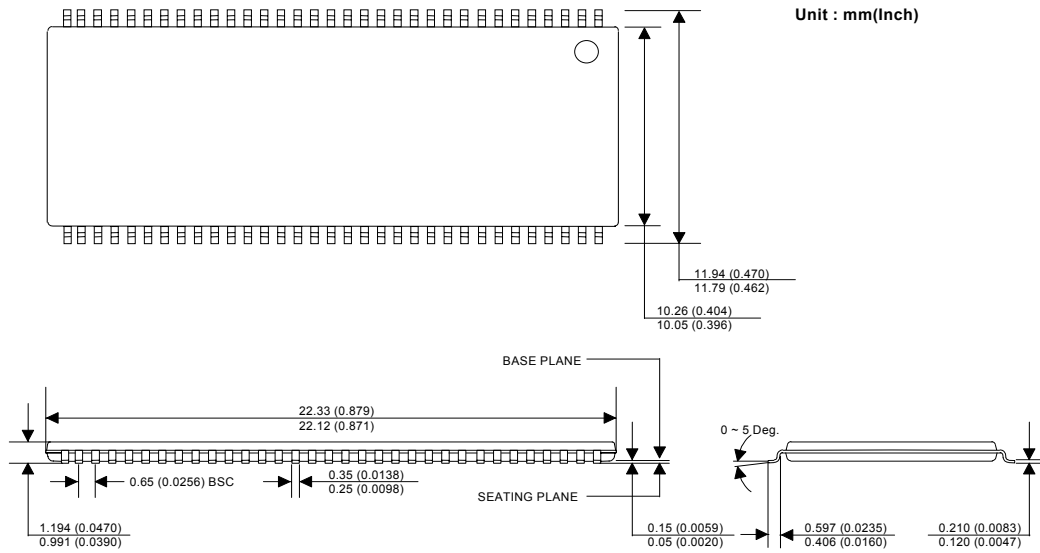

**Note :** Package do not mold protrusion. Allowable protrusion of both sides is 0.4mm.