

128Mbit GDDR SDRAM

Revision 1.8
March 2005

INFORMATION IN THIS DOCUMENT IS PROVIDED IN RELATION TO SAMSUNG PRODUCTS, AND IS SUBJECT TO CHANGE WITHOUT NOTICE.

NOTHING IN THIS DOCUMENT SHALL BE CONSTRUED AS GRANTING ANY LICENSE, EXPRESS OR IMPLIED, BY ESTOPPEL OR OTHERWISE,

TO ANY INTELLECTUAL PROPERTY RIGHTS IN SAMSUNG PRODUCTS OR TECHNOLOGY. ALL INFORMATION IN THIS DOCUMENT IS PROVIDED

ON AS "AS IS" BASIS WITHOUT GUARANTEE OR WARRANTY OF ANY KIND.

1. For updates or additional information about Samsung products, contact your nearest Samsung office.
2. Samsung products are not intended for use in life support, critical care, medical, safety equipment, or similar applications where Product failure could result in loss of life or personal or physical harm, or any military or defense application, or any governmental procurement to which special terms or provisions may apply.

Samsung Electronics reserves the right to change products or specification without notice.

Revision History**Revision 1.8 (March 5, 2005)**

- Remove 80% and 120% of the IBIS(I - V) curve in the data sheet

Revision 1.7 (February 5, 2005)

- Changed EMRS table for Driver Impedance control .
- Added IBIS (I - V) curve in the data sheet

Revision 1.6 (January 5, 2005)

- Added 200MHz/ 166MHz AC characteristics in AC CHARACTERISTICS (II) table of K4D263238G-VC2A and K4D263238G-VC33.
- Typo corrected

Revision 1.5 (December 29, 2004)

- Added tCK(min)=5ns @ CL3
- Changed tCK(max) of K4D263238G-GC2A from 4ns to 10ns

Revision 1.4 (November 30, 2004)

- Typo Corrected in DC table

Revision 1.3 (November 12, 2004)

- Changed AC spec format
- Changed DC spec measurement condition from VDD(typ) to VDD(max)

Revision 1.2 (October 18, 2004)

- Changed unit of tWR and tWR_A from ns to tCK to avoid misuse.
- Added lower speed timing set

Revision 1.1 (August 31, 2004)

- Added 100% driver strength option as A6A1="11"

Revision 1.0 (July 12, 2004)

- Defined DC spec

Revision 0.4 (June 20, 2004)

- Removed K4D26323QG-GC40/45 from the spec
- Added dummy cycle (20tCK) between EMRS and MRS during the power-up sequence.

Revision 0.3 (June 8, 2004)

- Internal only

Revision 0.2 (April 22, 2004)

- Changed CAS latency of K4D263238G-GC2A from 4tCK to 5tCK
- Changed tWR & tWR_A of K4D263238G-GC2A from 4tCK to 5tCK

Revision History**Revision 0.1 (April 19, 2004)**

- Changed tRCDRD of K4D263238G-GC33/36 from 4tCK to 5tCK
- Changed tRCDWR of K4D263238G-GC33/36 from 2tCK to 3tCK
- Changed tWR of K4D263238G-GC2A/33/36 from 3tCK to 4tCK.
- Changed tDAL of K4D263238G-GC2A from 8tCK to 9tCK
- Changed tDAL of K4D263238G-GC33/36 from 7tCK to 8tCK

Revision 0.0 (April 7, 2004) - *Target spec*

- Defined Target specification

**1M x 32Bit x 4 Banks Graphic Double Data Rate Synchronous DRAM
with Bi-directional Data Strobe and DLL****FEATURES**

- 2.5V ± 5% power supply for device operation
- 2.5V ± 5% power supply for I/O interface
- SSTL_2 compatible inputs/outputs
- 4 banks operation
- MRS cycle with address key programs
 - Read latency 3, 4 (clock)
 - Burst length (2, 4 and 8)
 - Burst type (sequential & interleave)
- All inputs except data & DM are sampled at the positive going edge of the system clock
- Differential clock input
- No Write-Interrupted by Read Function
- 4 DQS's (1DQS / Byte)
- Data I/O transactions on both edges of Data strobe
- DLL aligns DQ and DQS transitions with Clock transition
- Edge aligned data & data strobe output
- Center aligned data & data strobe input
- DM for write masking only
- Auto & Self refresh
- 32ms refresh period (4K cycle)
- 144-Ball FBGA
- Maximum clock frequency up to 350MHz
- Maximum data rate up to 700Mbps/pin

ORDERING INFORMATION

Part NO.	Max Freq.	Max Data Rate	Interface	Package
K4D263238G-GC2A	350MHz	700Mbps/pin	SSTL_2	144-Ball FBGA
K4D263238G-GC33	300MHz	600Mbps/pin		
K4D263238G-GC36	275MHz	550Mbps/pin		

K4D263238G-VC is the Lead Free package part number.

GENERAL DESCRIPTION**FOR 1M x 32Bit x 4 Bank DDR SDRAM**

The K4D263238G is 134,217,728 bits of hyper synchronous data rate Dynamic RAM organized as 4 x1,048,576 words by 32 bits, fabricated with SAMSUNG's high performance CMOS technology. Synchronous features with Data Strobe allow extremely high performance up to 2.8GB/s/chip. I/O transactions are possible on both edges of the clock cycle. Range of operating frequencies, programmable burst length and programmable latencies allow the device to be useful for a variety of high performance memory system applications.

PIN CONFIGURATION (Top View)

	2	3	4	5	6	7	8	9	10	11	12	13
B	DQS0	DM0	VSSQ	DQ3	DQ2	DQ0	DQ31	DQ29	DQ28	VSSQ	DM3	DQS3
C	DQ4	VDDQ	NC	VDDQ	DQ1	VDDQ	VDDQ	DQ30	VDDQ	NC	VDDQ	DQ27
D	DQ6	DQ5	VSSQ	VSSQ	VSSQ	VDD	VDD	VSSQ	VSSQ	VSSQ	DQ26	DQ25
E	DQ7	VDDQ	VDD	VSS	VSSQ	VSS	VSS	VSSQ	VSS	VDD	VDDQ	DQ24
F	DQ17	DQ16	VDDQ	VSSQ	VSS Thermal	VSS Thermal	VSS Thermal	VSS Thermal	VSSQ	VDDQ	DQ15	DQ14
G	DQ19	DQ18	VDDQ	VSSQ	VSS Thermal	VSS Thermal	VSS Thermal	VSS Thermal	VSSQ	VDDQ	DQ13	DQ12
H	DQS2	DM2	NC	VSSQ	VSS Thermal	VSS Thermal	VSS Thermal	VSS Thermal	VSSQ	NC	DM1	DQS1
J	DQ21	DQ20	VDDQ	VSSQ	VSS Thermal	VSS Thermal	VSS Thermal	VSS Thermal	VSSQ	VDDQ	DQ11	DQ10
K	DQ22	DQ23	VDDQ	VSSQ	VSS	VSS	VSS	VSS	VSSQ	VDDQ	DQ9	DQ8
L	$\overline{\text{CAS}}$	$\overline{\text{WE}}$	VDD	VSS	A10	VDD	VDD	RFU ₁	VSS	VDD	NC	NC
M	$\overline{\text{RAS}}$	NC	NC	BA1	A2	A11	A9	A5	RFU ₂	CK	$\overline{\text{CK}}$	MCL
N	$\overline{\text{CS}}$	NC	BA0	A0	A1	A3	A4	A6	A7	A8/AP	CKE	VREF

NOTE:

1. RFU1 is reserved for A12
2. RFU2 is reserved for BA2
3. VSS Thermal balls are optional

PIN DESCRIPTION

CK, $\overline{\text{CK}}$	Differential Clock Input	BA0, BA1	Bank Select Address
CKE	Clock Enable	A0 ~ A11	Address Input
$\overline{\text{CS}}$	Chip Select	DQ0 ~ DQ31	Data Input/Output
$\overline{\text{RAS}}$	Row Address Strobe	VDD	Power
$\overline{\text{CAS}}$	Column Address Strobe	VSS	Ground
WE	Write Enable	VDDQ	Power for DQ's
DQS	Data Strobe	VSSQ	Ground for DQ's
DM	Data Mask	NC	No Connection
RFU	Reserved for Future Use	MCL	Must Connect Low

INPUT/OUTPUT FUNCTIONAL DESCRIPTION

Symbol	Type	Function
CK, \overline{CK}^{*1}	Input	The differential system clock Input. All of the inputs are sampled on the rising edge of the clock except DQ's and DM's that are sampled on both edges of the DQS.
CKE	Input	Activates the CK signal when high and deactivates the \overline{CK} signal when low. By deactivating the clock, CKE low indicates the Power down mode or Self refresh mode.
\overline{CS}	Input	\overline{CS} enables the command decoder when low and disabled the command decoder when high. When the command decoder is disabled, new commands are ignored but previous operations continue.
\overline{RAS}	Input	Latches row addresses on the positive going edge of the CK with \overline{RAS} low. Enables row access & precharge.
\overline{CAS}	Input	Latches column addresses on the positive going edge of the CK with \overline{CAS} low. Enables column access.
\overline{WE}	Input	Enables write operation and row precharge. Latches data in starting from \overline{CAS} , \overline{WE} active.
DQS0 ~ DQS3	Input/Output	Data input and output are synchronized with both edge of DQS. DQS0 for DQ0 ~ DQ7, DQS1 for DQ8 ~ DQ15, DQS2 for DQ16 ~ DQ23, DQS3 for DQ24 ~ DQ31.
DM0 ~ DM3	Input	Data In mask. Data In is masked by DM Latency=0 when DM is high in burst write. DM0 for DQ0 ~ DQ7, DM1 for DQ8 ~ DQ15, DM2 for DQ16 ~ DQ23, DM3 for DQ24 ~ DQ31.
DQ0 ~ DQ31	Input/Output	Data inputs/Outputs are multiplexed on the same pins.
BA0, BA1	Input	Selects which bank is to be active.
A0 ~ A11	Input	Row/Column addresses are multiplexed on the same pins. Row addresses : RA0 ~ RA11, Column addresses : CA0 ~ CA7. Column address CA8 is used for auto precharge.
VDD/VSS	Power Supply	Power and ground for the input buffers and core logic.
VDDQ/VSSQ	Power Supply	Isolated power supply and ground for the output buffers to provide improved noise immunity.
VREF	Power Supply	Reference voltage for inputs, used for SSTL interface.
NC/RFU	No connection/ Reserved for future use	This pin is recommended to be left "No connection" on the device
MCL	Must Connect Low	Must connect low

*1 : The timing reference point for the differential clocking is the cross point of CK and \overline{CK} .

For any applications using the single ended clocking, apply VREF to \overline{CK} pin.

BLOCK DIAGRAM (1Mbit x 32I/O x 4 Bank)

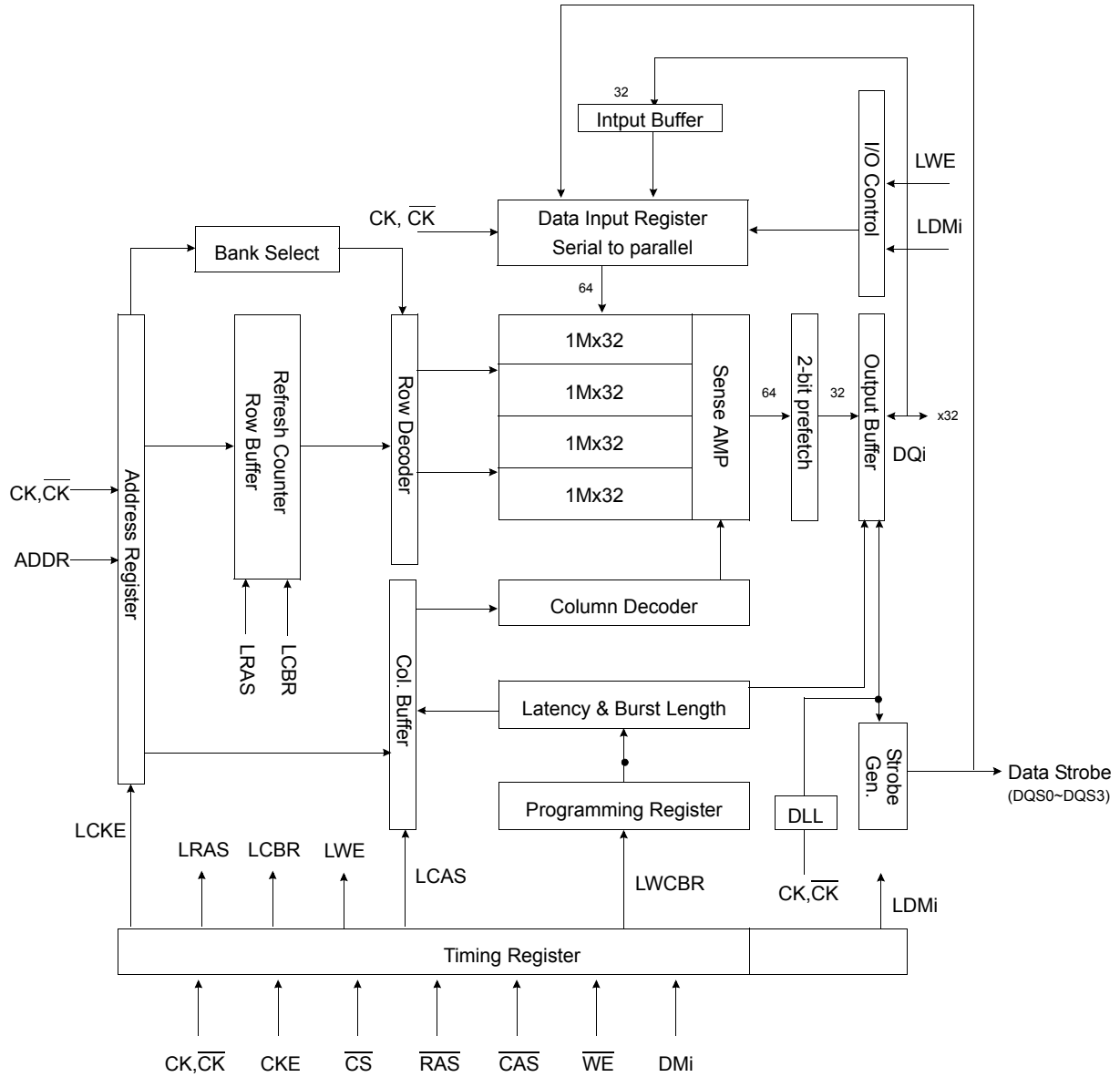

FUNCTIONAL DESCRIPTION

• Power-Up Sequence

DDR SDRAMs must be powered up and initialized in a predefined manner to prevent undefined operations.

1. Apply power and keep CKE at low state (All other inputs may be undefined)
 - Apply VDD before VDDQ .
 - Apply VDDQ before VREF & VTT
 2. Start clock and maintain stable condition for minimum 200us.
 3. The minimum of 200us after stable power and clock(CK,CK $\bar{}$), apply NOP and take CKE to be high .
 4. Issue precharge command for all banks of the device.
 5. Issue a EMRS command to enable DLL.
 - (Minimum 20 clock cycles are recommended prior to MRS command, however not mandatory just in case tMRD met)
 - *1 6. Issue a MRS command to reset DLL. The additional 200 clock cycles are required to lock the DLL.
 - *1,2 7. Issue precharge command for all banks of the device.
 8. Issue at least 2 or more auto-refresh commands.
 9. Issue a mode register set command with A8 to low to initialize the mode register.
- *1 The additional 200cycles of clock input is required to lock the DLL after enabling DLL.
 *2 Sequence of 6&7 is regardless of the order

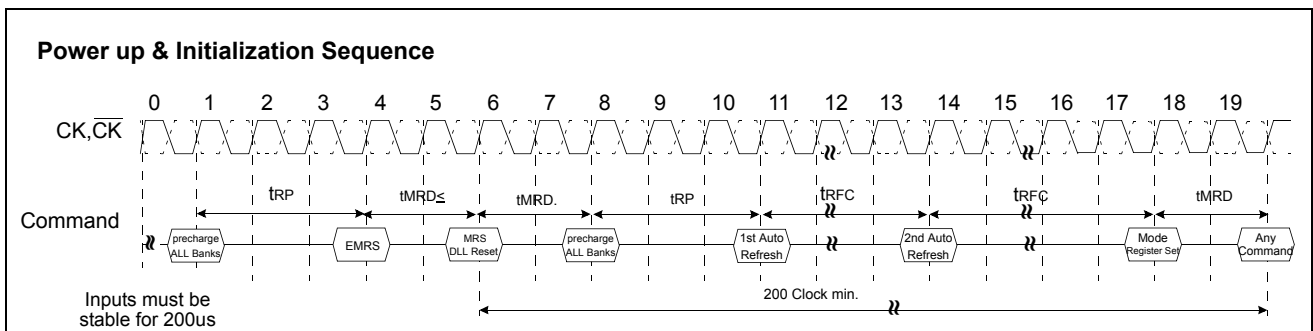

*** When the operating frequency is changed, DLL reset should be required again.
 After DLL reset again, the minimum 200 cycles of clock input is needed to lock the DLL.**

MODE REGISTER SET(MRS)

The mode register stores the data for controlling the various operating modes of DDR SDRAM. It programs CAS latency, addressing mode, burst length, test mode, DLL reset and various vendor specific options to make DDR SDRAM useful for variety of different applications. The default value of the mode register is not defined, therefore the mode register must be written after EMRS setting for proper operation. The mode register is written by asserting low on CS, RAS, CAS and WE (The DDR SDRAM should be in active mode with CKE already high prior to writing into the mode register). The state of address pins A0 ~ A11 and BA0, BA1 in the same cycle as CS, RAS, CAS and WE going low is written in the mode register. Minimum two clock cycles are requested to complete the write operation in the mode register. The mode register contents can be changed using the same command and clock cycle requirements during operation as long as all banks are in the idle state. The mode register is divided into various fields depending on functionality. The burst length uses A0 ~ A2, addressing mode uses A3, CAS latency(read latency from column address) uses A4 ~ A6. A7 is used for test mode. A8 is used for DLL reset. A7,A8, BA0 and BA1 must be set to low for normal MRS operation. Refer to the table for specific codes for various burst length, addressing modes and CAS latencies.

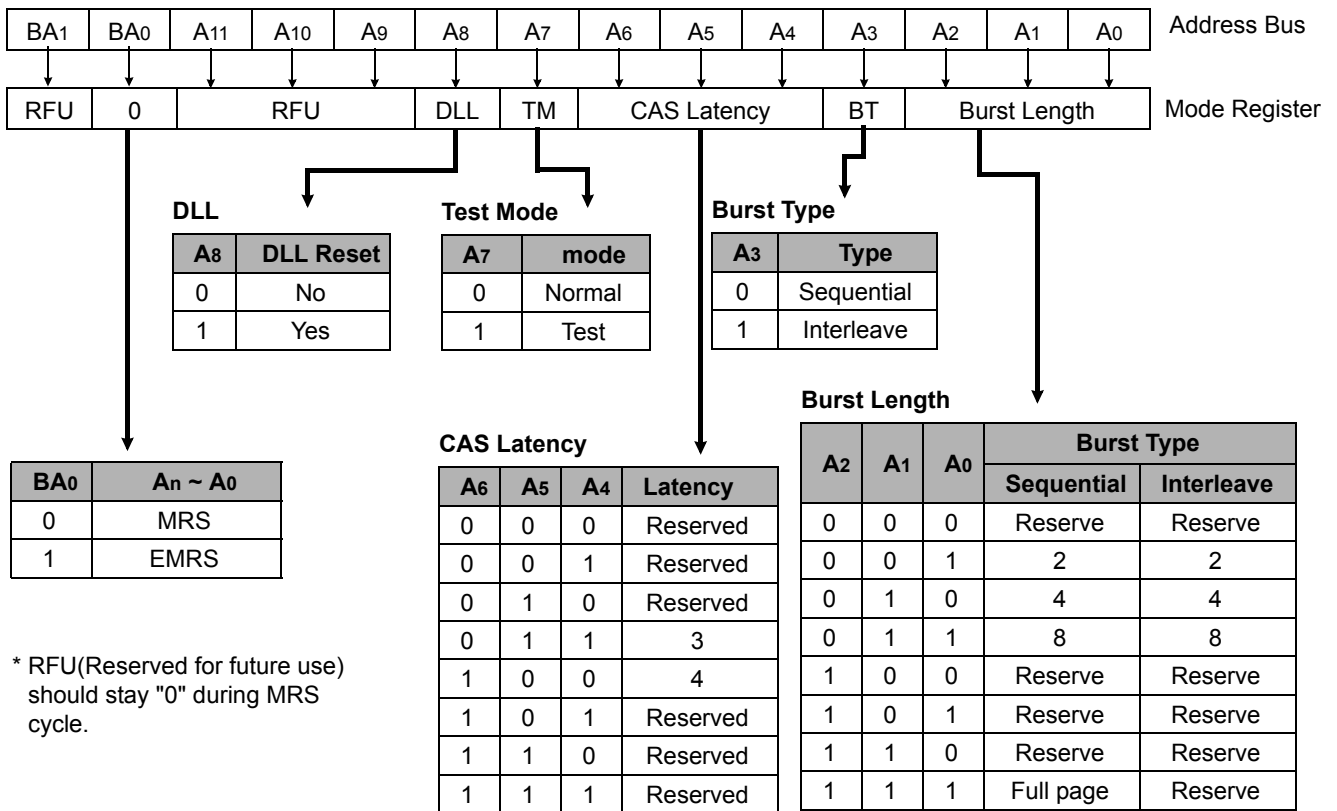

* RFU(Reserved for future use) should stay "0" during MRS cycle.

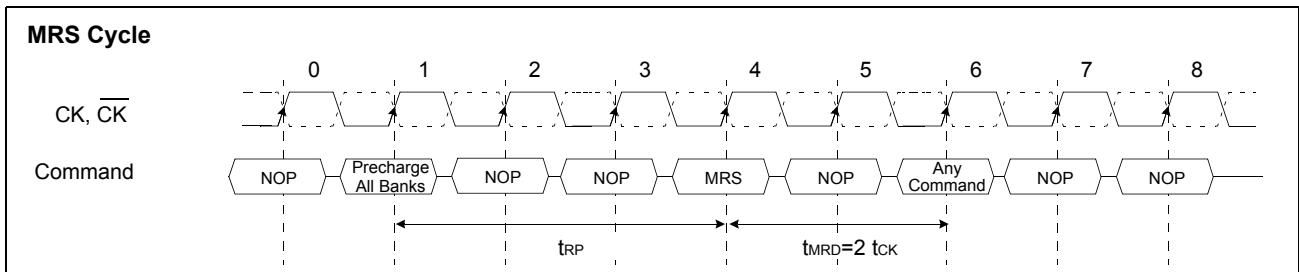

*1 : MRS can be issued only at all banks precharge state.
 *2 : Minimum trp is required to issue MRS command.

EXTENDED MODE REGISTER SET(EMRS)

The extended mode register stores the data for enabling or disabling DLL and selecting output driver strength. The default value of the extended mode register is not defined, therefore the extended mode register must be written after power up for enabling or disabling DLL. The extended mode register is written by asserting low on CS, RAS, CAS, WE and high on BA0(The DDR SDRAM should be in all bank precharge with CKE already high prior to writing into the extended mode register). The state of address pins A0, A2 ~ A5, A7 ~ A11 and BA1 in the same cycle as CS, RAS, CAS and WE going low are written in the extended mode register. A1 and A6 are used for setting driver strength to normal, weak or matched impedance. Two clock cycles are required to complete the write operation in the extended mode register. The mode register contents can be changed using the same command and clock cycle requirements during operation as long as all banks are in the idle state. A0 is used for DLL enable or disable. "High" on BA0 is used for EMRS. All the other address pins except A0,A1,A6 and BA0 must be set to low for proper EMRS operation. Refer to the table for specific codes.

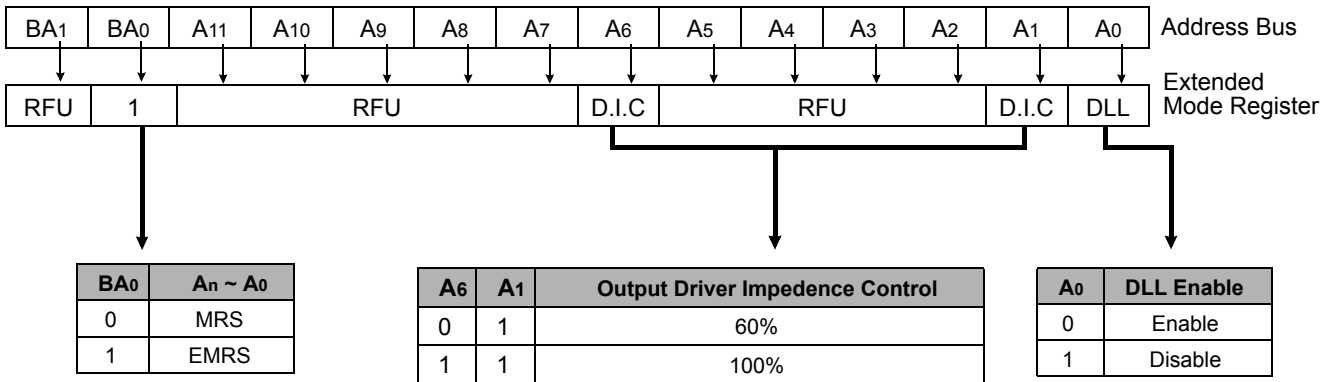

*1 : RFU(Reserved for future use) should stay "0" during EMRS cycle.

Figure 7. Extended Mode Register set

IBIS : I/V Characteristics for Input and Output Buffers

Voltage (V)	Pulldown Current (mA)		Pullup Current (mA)	
	60%	100%	60%	100%
0.0	-0.2	-0.36	5.04	8.12
0.1	2.12	3.04	2.64	4.28
0.2	4.32	6.24	0.24	0.52
0.3	6.44	9.32	-2.0	-3.08
0.4	8.32	12.2	-4.2	-6.52
0.5	10.0	14.8	-6.28	-9.84
0.6	11.6	17.1	-8.28	-13.0
0.7	13.0	19.0	-10.2	-16.0
0.8	14.0	20.7	-11.9	-18.8
0.9	15.0	22.0	-13.6	-21.5
1.0	15.6	23.0	-15.1	-23.9
1.1	16.1	23.7	-16.5	-26.1
1.2	16.5	24.2	-17.8	-28.1
1.3	16.8	24.6	-18.8	-29.9
1.4	17.0	25.0	-19.9	-31.5
1.5	17.0	25.1	-20.6	-32.9
1.6	17.2	25.3	-21.4	-34.1
1.7	17.3	25.4	-22.1	-35.1
1.8	17.4	25.6	-22.6	-36.0
1.9	17.4	25.6	-23.1	-36.7
2.0	17.5	25.8	-23.5	-37.4
2.1	17.6	25.8	-23.8	-37.9
2.2	17.6	25.9	-24.2	-38.4
2.3	17.7	26.0	-24.4	-38.9
2.4	17.7	26.1	-24.7	-39.3
2.5	17.8	26.1	-24.9	-39.7
2.6	17.8	26.2	-25.2	-40.1
2.7	17.8	26.2	-25.4	-40.4

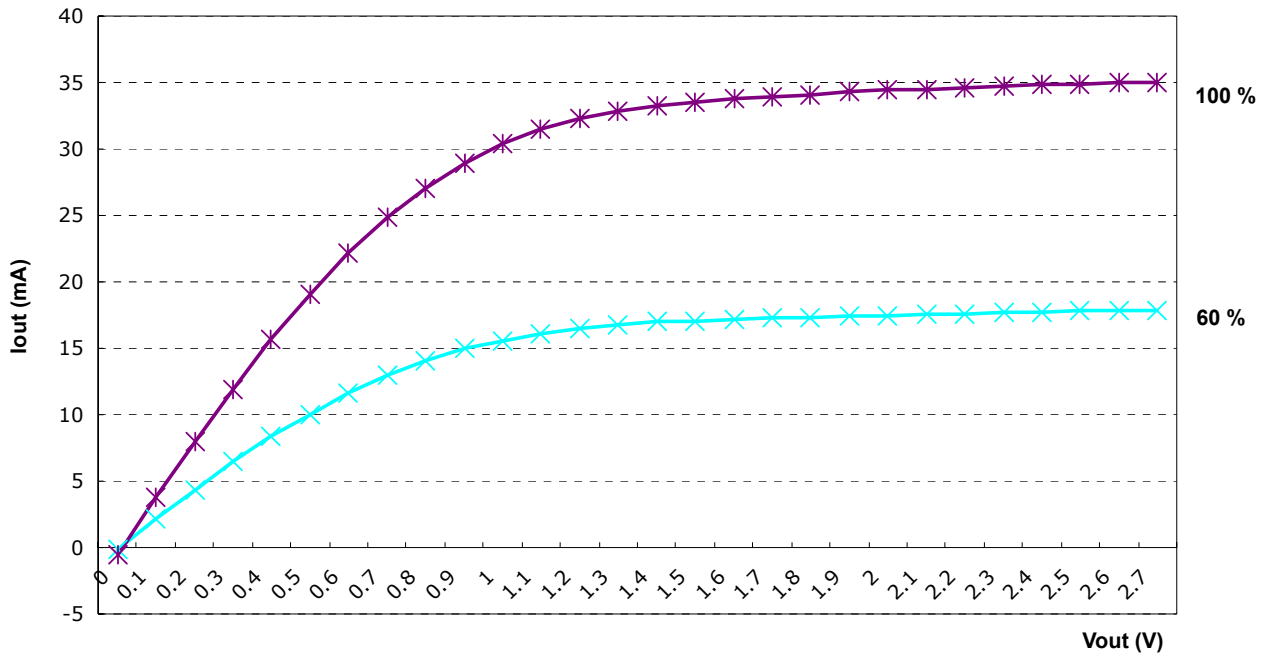

Pullup Characteristics I - V Curve

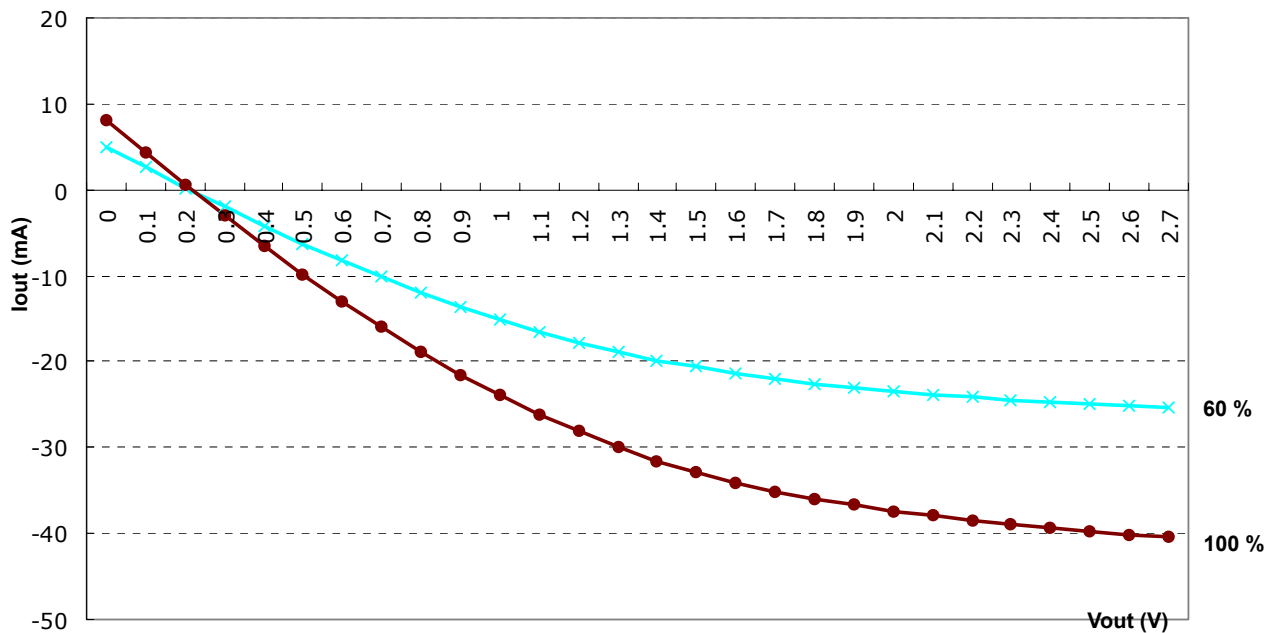

Pulldown Characteristics I - V Curve

ABSOLUTE MAXIMUM RATINGS

Parameter	Symbol	Value	Unit
Voltage on any pin relative to Vss	V _{IN} , V _{OUT}	-0.5 ~ 3.6	V
Voltage on VDD supply relative to Vss	VDD	-1.0 ~ 3.6	V
Voltage on VDDQ supply relative to Vss	VDDQ	-0.5 ~ 3.6	V
Storage temperature	T _{STG}	-55 ~ +150	°C
Power dissipation	P _D	3.3	W
Short circuit current	I _{OS}	50	mA

Note : Permanent device damage may occur if ABSOLUTE MAXIMUM RATINGS are exceeded.
 Functional operation should be restricted to recommended operating condition.
 Exposure to higher than recommended voltage for extended periods of time could affect device reliability.

POWER & DC OPERATING CONDITIONS(SSTL_2 In/Out)

Recommended operating conditions(Voltage referenced to Vss=0V, TA=0 to 65°C)

Parameter	Symbol	Min	Typ	Max	Unit	Note
Device Supply voltage	VDD	2.375	2.5	2.625	V	1
Output Supply voltage	VDDQ	2.375	2.5	2.625	V	1
Reference voltage	VREF	0.49*VDDQ	-	0.51*VDDQ	V	2
Termination voltage	V _{tt}	VREF-0.04	VREF	VREF+0.04	V	3
Input logic high voltage	V _{IH(DC)}	VREF+0.15	-	VDDQ+0.30	V	4
Input logic low voltage	V _{IL(DC)}	-0.30	-	VREF-0.15	V	5
Output logic high voltage	V _{OH}	V _{tt} +0.76	-	-	V	I _{OH} =-15.2mA, 7
Output logic low voltage	V _{OL}	-	-	V _{tt} -0.76	V	I _{OL} =+15.2mA, 7
Input leakage current	I _{IL}	-5	-	5	uA	6
Output leakage current	I _{OL}	-5	-	5	uA	6

- Note** :
- Under all conditions VDDQ must be less than or equal to VDD.
 - VREF is expected to equal 0.50*VDDQ of the transmitting device and to track variations in the DC level of the same. Peak to peak noise on the VREF may not exceed + 2% of the DC value.
 - V_{tt} of the transmitting device must track VREF of the receiving device.
 - V_{IH(max.)}= VDDQ +1.5V for a pulse width and it can not be greater than 1/3 of the cycle rate.
 - V_{IL(min.)}= -1.5V for a pulse width and it can not be greater than 1/3 of the cycle rate.
 - For any pin under test input of 0V ≤ V_{IN} ≤ VDD is acceptable. For all other pins that are not under test V_{IN}=0V.
 - Output logic high voltage and low voltage is depend on output channel condition.

DC CHARACTERISTICS

Recommended operating conditions Unless Otherwise Noted, TA=0 to 65°C)

Parameter	Symbol	Test Condition	Version			Unit	Note
			-2A	-33	-36		
Operating Current (One Bank Active)	I _{CC1}	Burst Lenth=2 t _{RC} ≥ t _{RC} (min) I _{OL} =0mA, t _{CC} = t _{CC} (min)	315	285	270	mA	1
Precharge Standby Current in Power-down mode	I _{CC2P}	CKE ≤ V _{IL} (max), t _{CC} = t _{CC} (min)	15	15	15	mA	
Precharge Standby Current in Non Power-down mode	I _{CC2N}	CKE ≥ V _{IH} (min), CS ≥ V _{IH} (min), t _{CC} = t _{CC} (min)	75	65	65	mA	
Active Standby Current power-down mode	I _{CC3P}	CKE ≤ V _{IL} (max), t _{CC} = t _{CC} (min)	75	70	65	mA	
Active Standby Current in Non Power-down mode	I _{CC3N}	CKE ≥ V _{IH} (min), CS ≥ V _{IH} (min), t _{CC} = t _{CC} (min)	240	220	210	mA	
Operating Current (Burst Mode)	I _{CC4}	I _{OL} =0mA ,t _{CC} = t _{CC} (min), Page Burst, All Banks activated.	505	465	445	mA	
Refresh Current	I _{CC5}	t _{RC} ≥ t _{RFC} (min)	280	250	230	mA	2
Self Refresh Current	I _{CC6}	CKE ≤ 0.2V	8	8	8	mA	
Operating Current (4Bank interleaving)	I _{CC7}	Burst Length=4 t _{RC} ≥ t _{RC} (min) I _{OL} =0mA, t _{CC} = t _{CC} (min)	600	550	520	mA	

- Note** : 1. Measured with outputs open.
2. Refresh period is 32ms.
3. Current measured at VDD(max)

AC INPUT OPERATING CONDITIONSRecommended operating conditions(Voltage referenced to V_{SS}=0V, TA=0 to 65°C)

Parameter	Symbol	Min	Typ	Max	Unit	Note
Input High (Logic 1) Voltage ;DQ	V _{IH}	V _{REF} +0.35	-	-	V	
Input Low (Logic 0) Voltage; DQ	V _{IL}	-	-	V _{REF} -0.35	V	
Clock Input Differential Voltage; CK and \overline{CK}	V _{ID}	0.7	-	V _{DDQ} +0.6	V	1
Clock Input Crossing Point Voltage; CK and \overline{CK}	V _{IX}	0.5*V _{DDQ} -0.2	-	0.5*V _{DDQ} +0.2	V	2

- Note** : 1. V_{ID} is the magnitude of the difference between the input level on CK and the input level on \overline{CK}
2. The value of V_{IX} is expected to equal 0.5*V_{DDQ} of the transmitting device and must track variations in the DC level of the same

AC OPERATING TEST CONDITIONS (TA= 0 to 65°C)

Parameter	Value	Unit	Note
Input reference voltage for CK(for single ended)	0.50*VDDQ	V	1
CK and \overline{CK} signal maximum peak swing	1.5	V	
CK signal minimum slew rate	1.0	V/ns	
Input Levels(VIH/VIL)	VREF+0.4/VREF-0.4	V	
Input timing measurement reference level	VREF	V	
Output timing measurement reference level	Vtt	V	
Output load condition	See Fig.1		

Note 1 : In case of differential clocks(CK and \overline{CK}), input reference voltage for clock is a CK and \overline{CK} 's crossing point
Accordingly, clock duty should be measured at a CK and \overline{CK} 's crossing point.

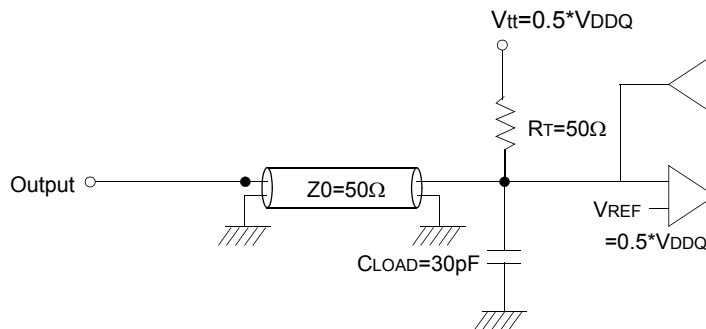

(Fig. 1) Output Load Circuit

CAPACITANCE (TA= 25°C, f=1MHz)

Parameter	Symbol	Min	Max	Unit
Input capacitance(CK, \overline{CK})	CIN1	1.0	5.0	pF
Input capacitance(A0~A11, BA0~BA1)	CIN2	1.0	4.0	pF
Input capacitance(CKE, \overline{CS} , RAS, CAS, \overline{WE})	CIN3	1.0	4.0	pF
Data & DQS input/output capacitance(DQ0~DQ31)	COUT	1.0	6.5	pF
Input capacitance(DM0 ~ DM3)	CIN4	1.0	6.5	pF

DECOUPLING CAPACITANCE GUIDE LINE

Recommended decoupling capacitance added to power line at board.

Parameter	Symbol	Value	Unit
Decoupling Capacitance between VDD and Vss	CDC1	0.1 + 0.01	uF
Decoupling Capacitance between VDDQ and VSSQ	CDC2	0.1 + 0.01	uF

Note : 1. VDD and VDDQ pins are separated each other.
All VDD pins are connected in chip. All VDDQ pins are connected in chip.
2. Vss and VSSQ pins are separated each other
All Vss pins are connected in chip. All VSSQ pins are connected in chip.

AC CHARACTERISTICS

Parameter	Symbol	-2A		-33		-36		Unit	Note	
		Min	Max	Min	Max	Min	Max			
CK cycle time	CL=3 CL=4	tCK	5	10	5	10	5	10	ns	
			2.86		3.3		3.6		ns	
CK high level width	tCH	0.45	0.55	0.45	0.55	0.45	0.55	tCK		
CK low level width	tCL	0.45	0.55	0.45	0.55	0.45	0.55	tCK		
DQS out access time from CK	tDQSK	-0.55	0.55	-0.55	0.55	-0.6	0.6	ns		
Output access time from CK	tAC	-0.55	0.55	-0.55	0.55	-0.6	0.6	ns		
Data strobe edge to Dout edge	tDQSQ	-	0.35	-	0.35	-	0.40	ns	1	
Read preamble	tRPRE	0.9	1.1	0.9	1.1	0.9	1.1	tCK		
Read postamble	tRPST	0.4	0.6	0.4	0.6	0.4	0.6	tCK		
CK to valid DQS-in	tDQSS	0.85	1.15	0.85	1.15	0.85	1.15	tCK		
DQS-In setup time	tWPRES	0	-	0	-	0	-	ns		
DQS-in hold time	tWPREH	0.35	-	0.35	-	0.35	-	tCK		
DQS write postamble	tWPST	0.4	0.6	0.4	0.6	0.4	0.6	tCK		
DQS-In high level width	tDQSH	0.45	0.55	0.45	0.55	0.45	0.55	tCK		
DQS-In low level width	tDQSL	0.45	0.55	0.45	0.55	0.45	0.55	tCK		
Address and Control input setup	tIS	0.8	-	0.8	-	0.9	-	ns		
Address and Control input hold	tIH	0.8	-	0.8	-	0.9	-	ns		
DQ and DM setup time to DQS	tDS	0.35	-	0.35	-	0.40	-	ns		
DQ and DM hold time to DQS	tDH	0.35	-	0.35	-	0.40	-	ns		
Clock half period	tHP	tCLmin	-	tCLmin	-	tCLmin	-	ns	1	
		tCHmin	-	tCHmin	-	tCHmin	-			
Data Hold skew factor	tQHS	-	0.4	-	0.4	-	0.45	ns		
Data output hold time from DQS	tQH	tHP-tQHS	-	tHP-tQHS	-	tHP-tQHS	-	ns	1	
Jitter over 1~6 clock cycle error	tJ*1	-	75	-	85	-	95	ps		
Cycle to cycle duty cycle error	tDCERR	-	75	-	85	-	95	ps		
Rise and fall times of CK	tR, tF	-	600	-	700	-	700	ps		

*1. The cycle to cycle jitter over 1~6 cycle short term jitter.

Simplified Timing @ BL=2, CL=4

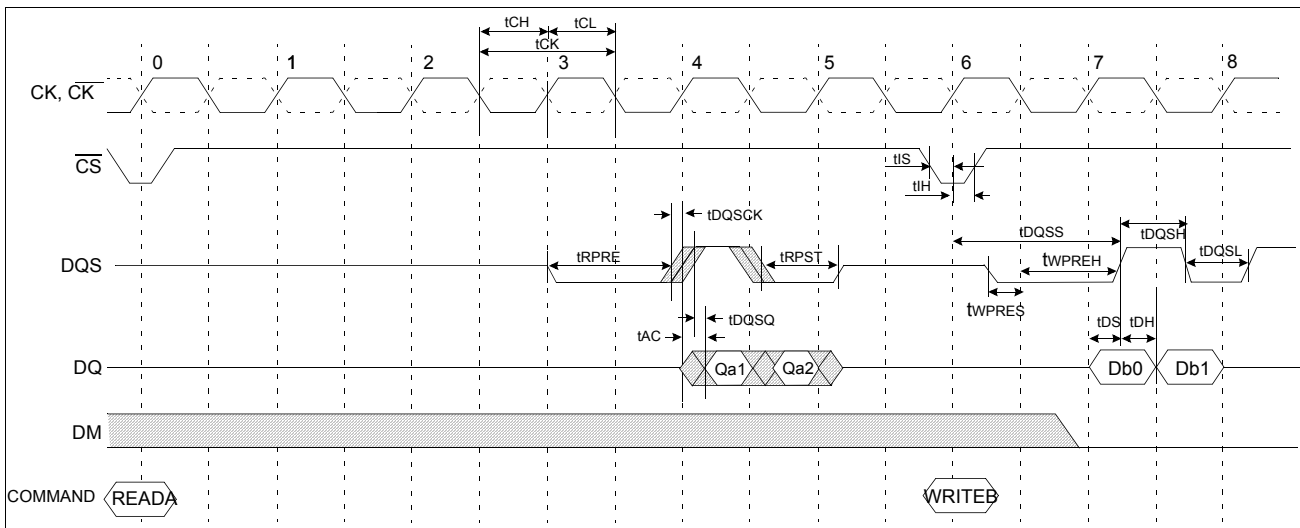

Note 1 :

- The JEDEC DDR specification currently defines the output data valid window(t_{DV}) as the time period when the data strobe and all data associated with that data strobe are coincidentally valid.
- The previously used definition of $t_{DV}(=0.35t_{CK})$ artificially penalizes system timing budgets by assuming the worst case output valid window even then the clock duty cycle applied to the device is better than 45/55%
- A new AC timing term, t_{QH} which stands for data output hold time from DQS is defined to account for clock duty cycle variation and replaces t_{DV}
- $t_{QHmin} = t_{HP}-X$ where
 - . t_{HP} =Minimum half clock period for any given cycle and is defined by clock high or clock low time(t_{CH},t_{CL})
 - . X =A frequency dependent timing allowance account for $t_{DQSQmax}$

t_{QH} Timing (CL4, BL2)

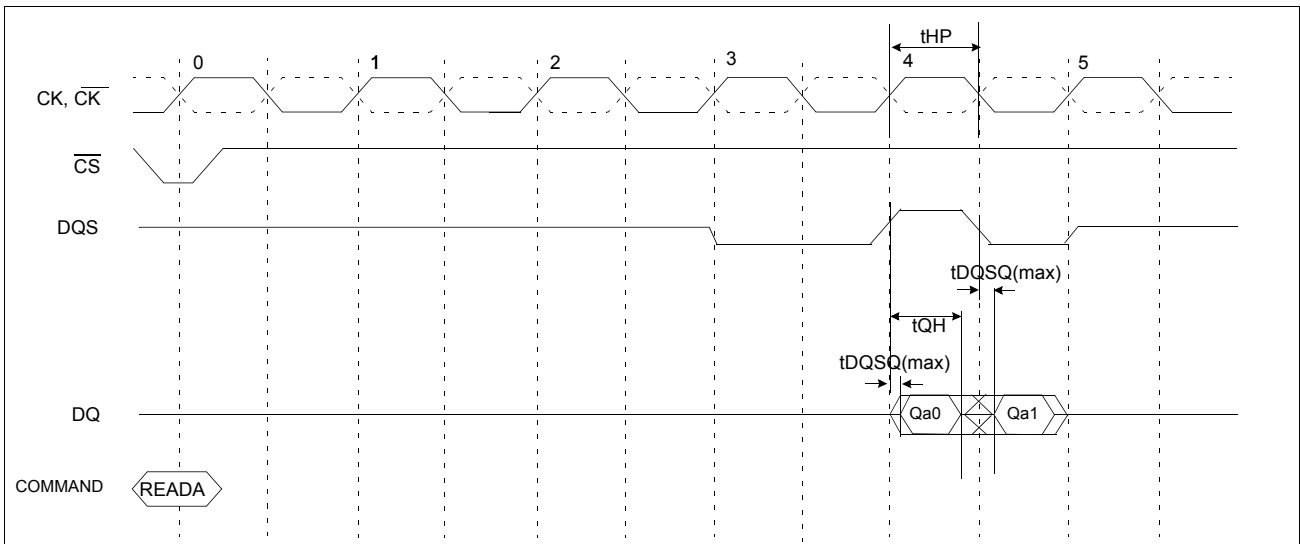

Power Down Timing

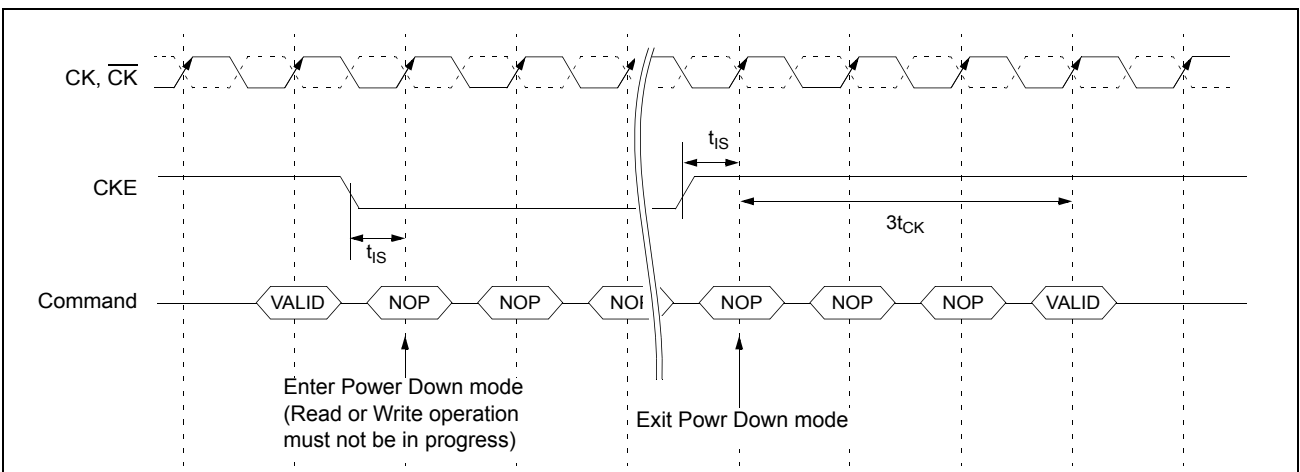

AC CHARACTERISTICS (I)

Parameter	Symbol	-2A		-33		-36		Unit	Note
		Min	Max	Min	Max	Min	Max		
Row cycle time	tRC	42.9	-	42.9	-	46.8	-	ns	2,5
Refresh row cycle time	tRFC	48.6	-	49.5	-	54	-	ns	5
Row active time	tRAS	28.6	100K	29.7	100K	32.4	100K	ns	5
RAS to CAS delay for Read	tRCDRD	13.2	-	13.2	-	14.4	-	ns	5
RAS to CAS delay for Write	tRCDWR	6.6	-	6.6	-	7.2	-	ns	4
Row precharge time	tRP	13.2	-	13.2	-	14.4	-	ns	5
Row active to Row active	tRRD	9.9	-	9.9	-	10.8	-	ns	5
Last data in to Row precharge	tWR	14.3	-	16.5	-	18	-	ns	5
Last data in to Row precharge @Auto Precharge	tWR_A	5	-	5	-	5	-	tCK	3
Auto precharge write recovery + Pre-charge	tDAL	10	-	9	-	9	-	tCK	3,5
Last data in to Read command	tCDLR	2	-	2	-	2	-	tCK	1
Col. address to Col. address	tCCD	1	-	1	-	1	-	tCK	
Mode register set cycle time	tMRD	2	-	2	-	2	-	tCK	
Exit self refresh to read command	tXSR	200	-	200	-	200	-	tCK	
Power down exit time	tPDEX	3tCK+ tIS	-	3tCK+ tIS	-	3tCK+ tIS	-	ns	
Refresh interval time	tREF	7.8	-	7.8	-	7.8	-	us	

- Note : 1. For normal write operation, even numbers of Din are to be written inside DRAM
2. The number of clock of tRP is restricted by the number of clock of tRAS and tRP
3. The number of clock of tWR_A is fixed. It can't be changed by tCK
4. tRCDWR is equal to tRCDRD-2tCK and the number of clock can not be lower than 2tCK.
5. The minimum number of clock cycles is determined by dividing the minimum time required with clock cycle time and then rounding off to the next higher integer unconditionally.

AC CHARACTERISTICS (II)

K4D263238G-GC2A

Frequency	Cas Latency	tRC	tRFC	tRAS	tRCDRD	tRCDWR	tRP	tRRD	tDAL	Unit
350MHz (2.86ns)	4	15	17	10	5	3	5	4	10	tCK
300MHz (3.3ns)	4	13	15	9	4	2	4	3	9	tCK
275MHz (3.6ns)	4	13	15	9	4	2	4	3	9	tCK
200MHz (5.0ns)	3	10	11	7	3	2	3	3	8	tCK
166MHz (6.0ns)	3	8	9	6	3	2	3	2	8	tCK

K4D263238G-GC33

Frequency	Cas Latency	tRC	tRFC	tRAS	tRCDRD	tRCDWR	tRP	tRRD	tDAL	Unit
300MHz (3.3ns)	4	13	15	9	4	2	4	3	9	tCK
275MHz (3.6ns)	4	13	15	9	4	2	4	3	9	tCK
200MHz (5.0ns)	3	10	11	7	3	2	3	3	8	tCK
166MHz (6.0ns)	3	8	9	6	3	2	3	2	8	tCK

K4D263238G-GC36

Frequency	Cas Latency	tRC	tRFC	tRAS	tRCDRD	tRCDWR	tRP	tRRD	tDAL	Unit
275MHz (3.6ns)	4	13	15	9	4	2	4	3	9	tCK
200MHz (5.0ns)	3	10	11	7	3	2	3	3	8	tCK
166MHz (6.0ns)	3	8	9	6	3	2	3	2	8	tCK

PACKAGE DIMENSIONS (144-Ball FBGA)

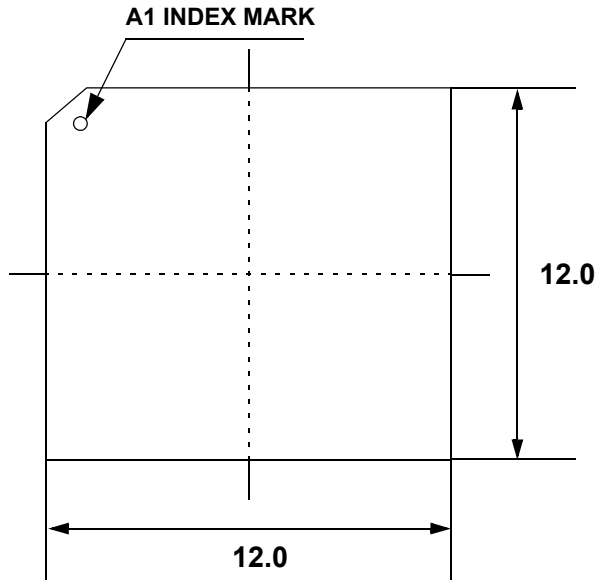

<Top View>

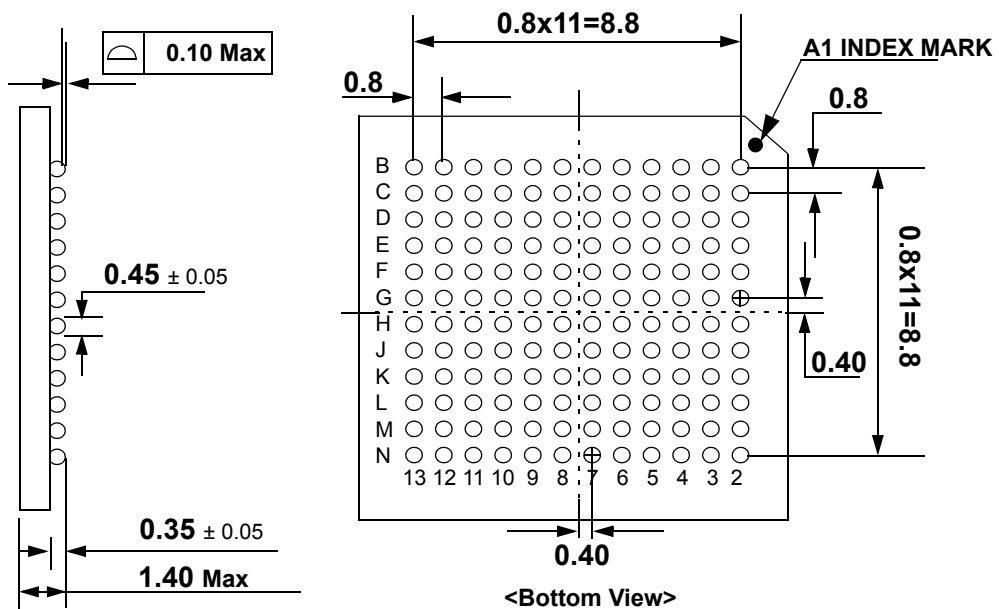

<Bottom View>

Unit : mm