

HIGH DENSITY PIN & SOCKET P.C. BOARD CONNECTORS Up to 90 CONTACTS

- Any even number contact positions up to 90 available²
- Very low mating forces
- 2 styles
 - plug (with pins) to receptacle (with sockets)
 - pins (bed of nails) to receptacle with sockets
- Alignment pins and keying optional⁶
- Plugs and carriers have male contacts.
- Receptacles have female contacts.
- $\varnothing.018$ " (.45mm) pins
- Two rows on $.100$ " (2.54mm) x $.100$ " (2.54mm) centers
- Parallel board connectors
- As little as $.240$ " (6.1mm) or $.480$ " (12.2mm) between boards

GENERAL SPECIFICATIONS

Number Contacts	22 - 90 (any even no. contact count up to 90 available)
Contact Diameter	.018 (.45)
Current Rating	2.5 amps
Contact Resistance	< 8 milliohms
Extraction Force	.3 - 2 oz.
Contact Life Cycles	100,000
Breakdown voltage between contacts	>1200V RMS
Dielectric Withstanding Voltage:	900V RMS
Insulation Resistance	>10 ⁵ Megohms @ 500 VDC
Insulator Material/ Temperature Rating:	Nylon -55°C to + 105°C
Contact Material: Plating:	Brass (pin) BeCu wires & brass body (socket) Gold over nickel
Guide Hardware	Stainless steel

Plating Reference

Male Pins: TH = 50 μ in gold (min) over Ni

Female Sockets: TAH = 50 μ in gold (min) over Ni on mating surface, gold flash over Ni on termination
TABH = 50 μ in gold (min) over Ni on mating surface, tin/lead over Ni on termination (straight D style only)

Standard Sizes (other sizes available)

No. of Contacts ⁵	22	24	44	46	66	68	90
Dim. A	1.000 (25.40)	1.100 (27.94)	2.100 (53.34)	2.200 (55.88)	3.200 (81.28)	3.300 (83.82)	4.400 (111.76)
Dim. B ³	1.141 (28.99)	1.239 (31.47)	2.239 (56.87)	2.341 (59.47)	3.341 (84.86)	3.441 (87.41)	4.557 (115.76)

Notes

- 1) Dimensions in inches (mm).
- 2) Standoffs location will vary depending on the number of contact positions.
- 3) Tolerance: $\pm .020$ (.5).
- 4) Insulators with < 22 contact positions will not have standoffs.
- 5) Sizes that have standoffs at end position.
- 6) Keying is accomplished by locating alignment pins in different positions.

CONNECTOR DIMENSIONS¹

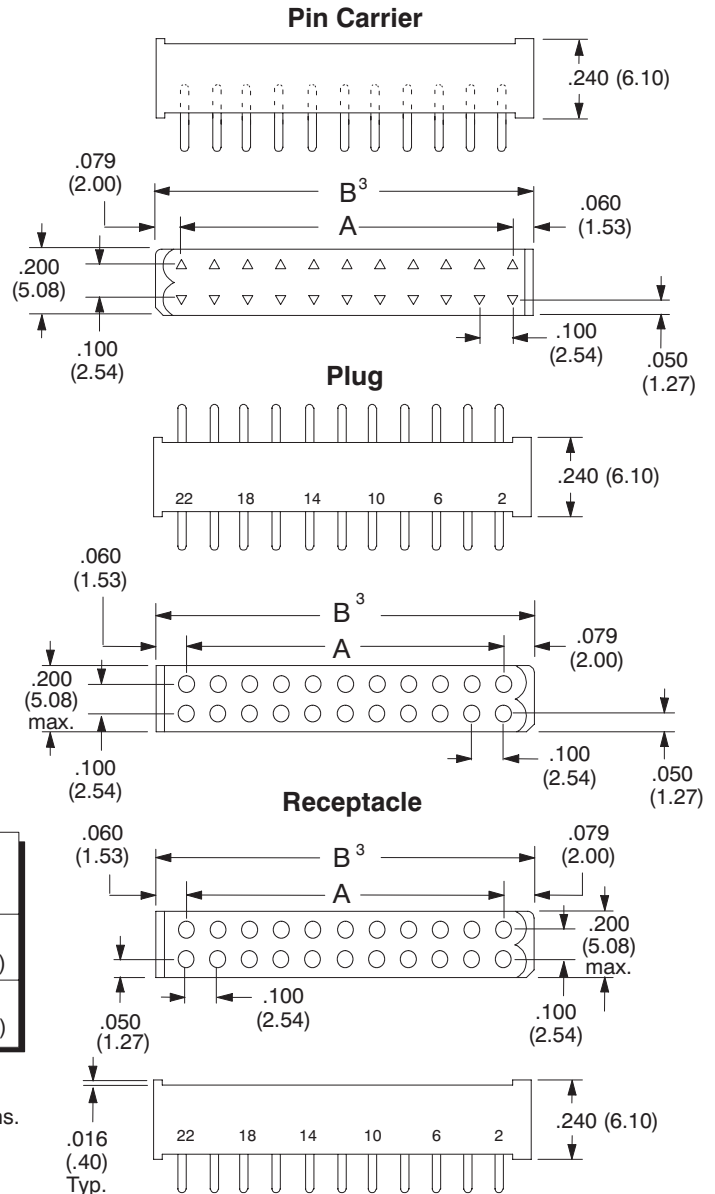

TERMINAL STYLES

Ref.

Pin Carrier

Plugs

Receptacles

D
Straight dip
solder

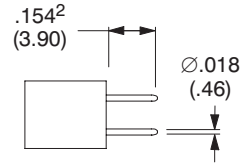
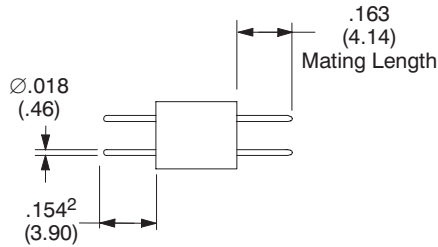
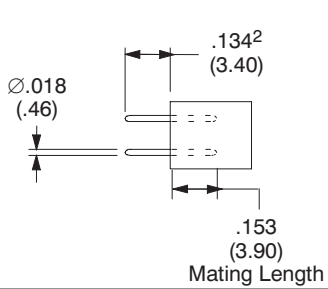

R⁴
Crimp
Accepts 22,
24 and 26
AWG wire
stripped back
.173 (4.4)

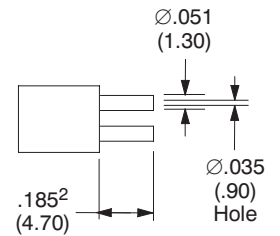
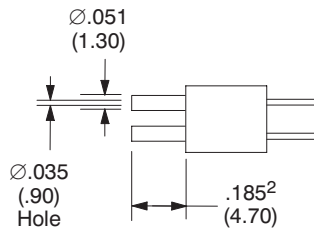

S
Solder cup
Accepts up to
22 AWG wire
stripped back
.125 (3.2)

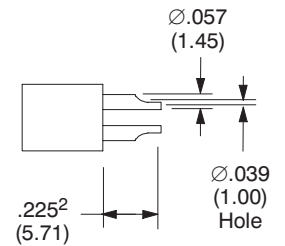
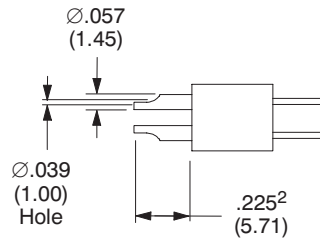

Notes:

- 1) Dimensions in inches (mm).
- 2) All dimensions are based upon insulators having standoffs.
- 3) All the tails are ± .015 (.4) long.
- 4) Crimp contacts will be shipped unmounted.

MOUNTING STYLES

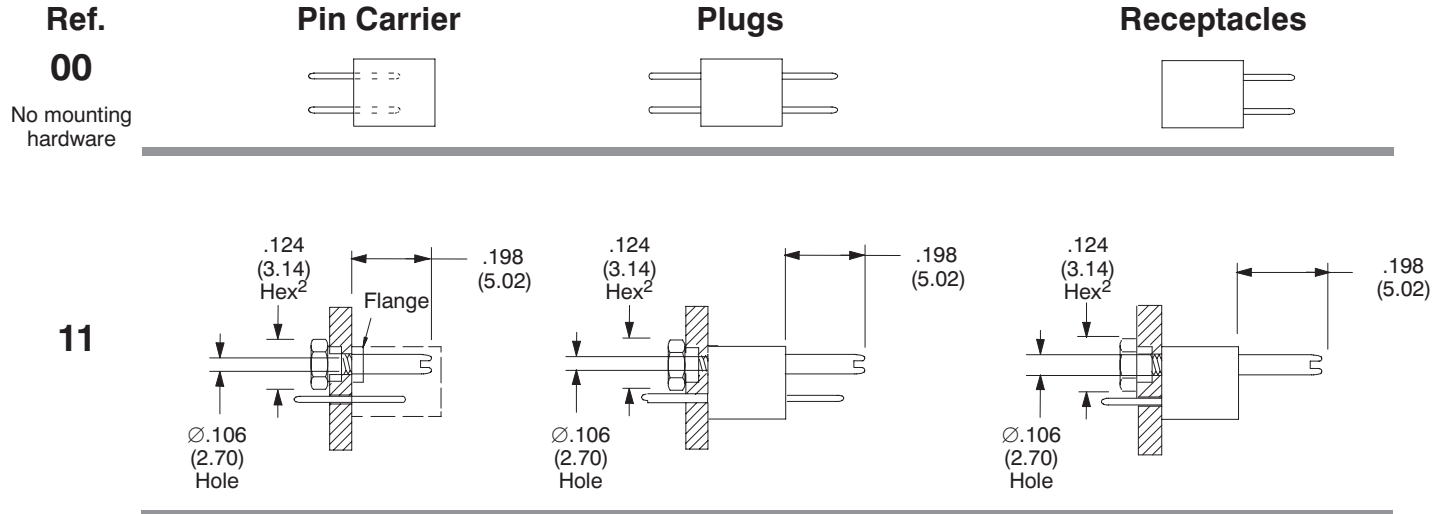

MOUNTING DIMENSIONS¹
(Top of Board)

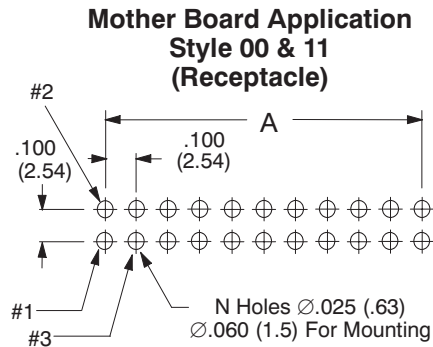

No. of Contacts	22	24	44	46	66	68	90
Dim. A	1.000 (25.40)	1.100 (27.94)	2.100 (53.34)	2.200 (55.88)	3.200 (81.28)	3.300 (83.82)	4.400 (111.76)

Notes:

- 1) Dimensions in inches (mm)
- 2) 9.5 oz.in [.07 N•m (.68kg•cm)] torque.

**ASSEMBLY METHOD
with pin carrier**

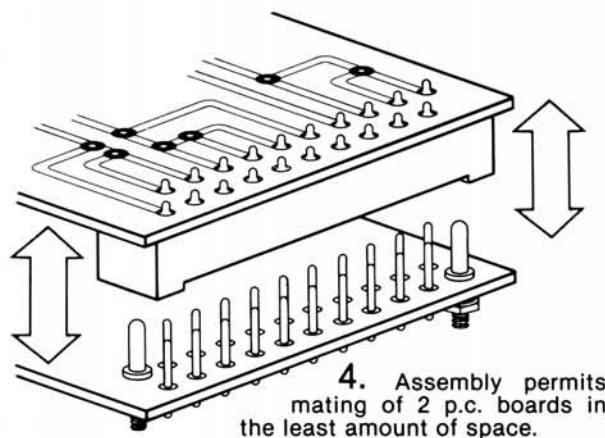
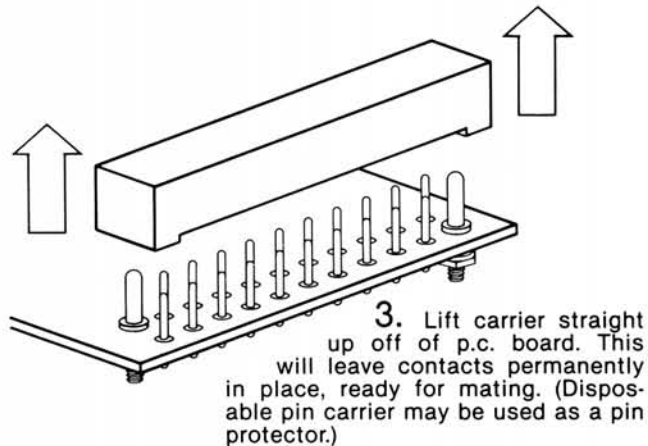
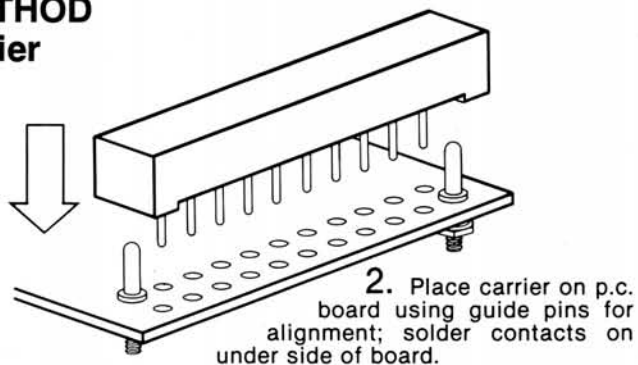
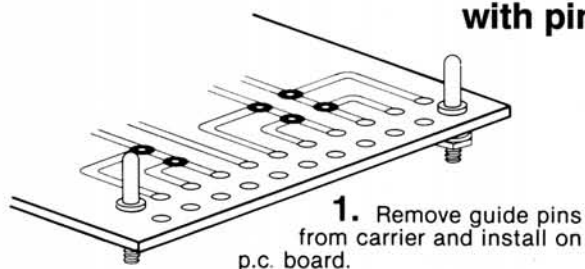

Notes:

- 1) Number of contacts. (special pad configuration required next to mounting holes).
- 2) See pg. 65 for a description of mounting styles/guides/keys.
- 3) Dimensions in inches (mm).

TYPICAL APPLICATIONS

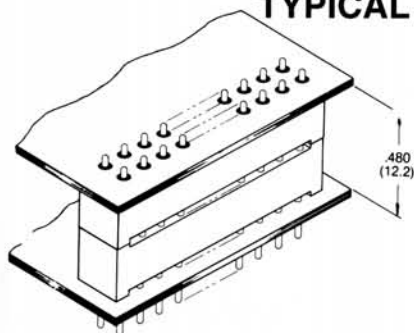

P.C. Board to P.C. Board —
Thick Parallel Sandwich
for tall board components
[Mounting Style 00 to 00]

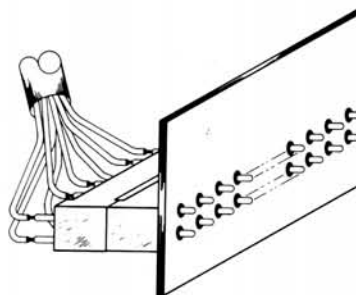

Cable to P.C. Board
[Mounting Style 00 to 00]

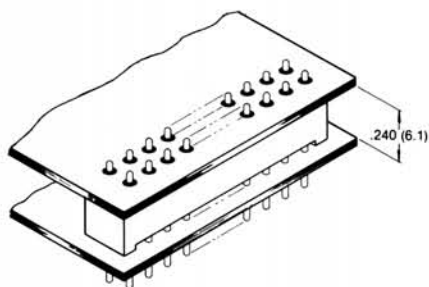

P.C. Board to P.C. Board —
Thin Parallel Sandwich
for maximum density
[Mounting Style 00 to 00 (Carrier)]

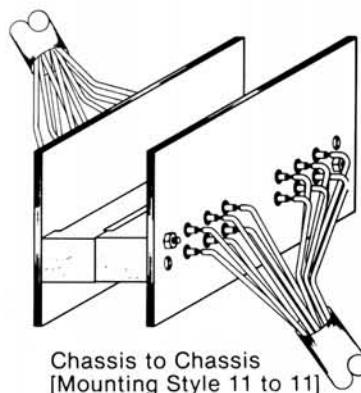

Chassis to Chassis
[Mounting Style 11 to 11]

ORDERING INFORMATION

KG 22 B P D 11

TH-P2-21-H1-22

KG 22 B E D 11

TABH-P1-22-H2-21

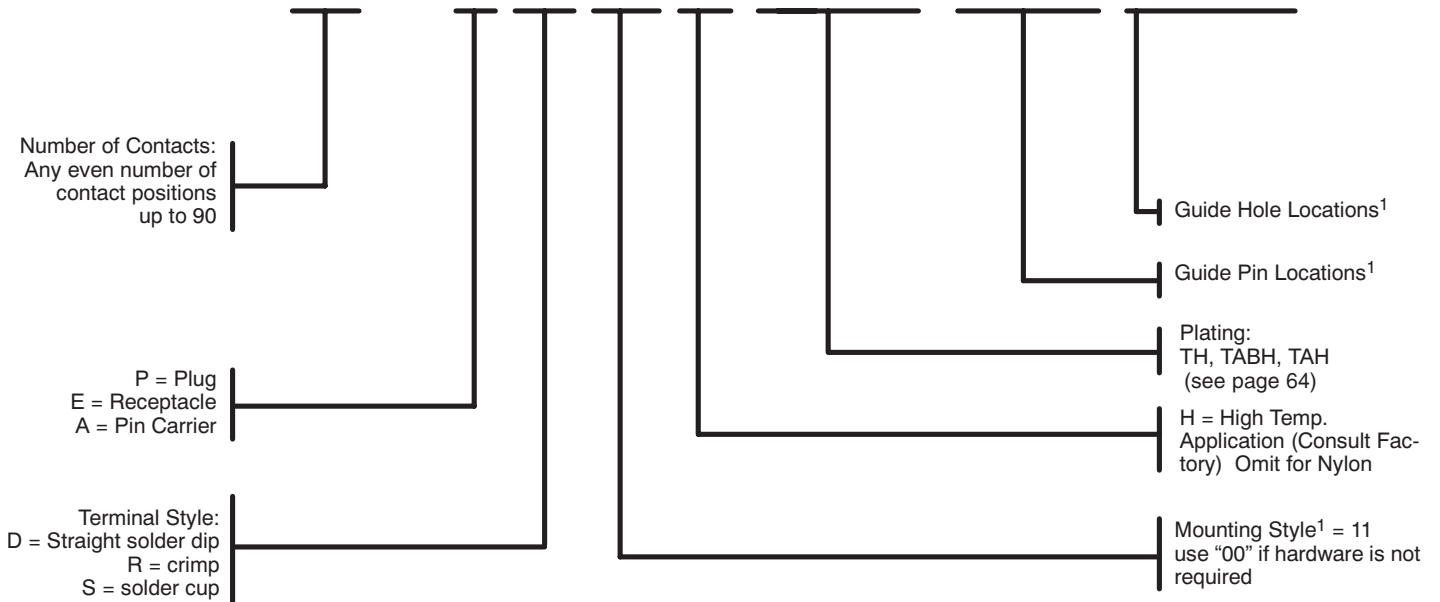

ACCESSORIES	
Crimp Tool	AFM8 or (M22520/2-01)
Positioner	SS1.0045
Insertion Tool	S/MONT1.0045

Notes:

- 1) Style 11 uses 1 contact position per guide pin. For a mated pair, holes and guides must be complementary (i.e., if position 1 in the plug has a guide pin then, position 1 in the receptacle must have a guide hole, etc.). If omitted, connectors will be shipped fully loaded without guiding hardware.