



OHM4 Series 5.0V CMOS Oven Controlled Oscillators

October 2007

- Ovenized quartz crystal high precision square wave generator with a CMOS output.
- Tube packaging is available.
- 10 to 40 MHz
- Full Size Thru-Hole DIP package
- Electronic Frequency Control (EFC) optional
- Low Jitter - Good phase noise characteristics

Pletronics Inc. certifies this device is in accordance with the RoHS 6/6 (2002/95/EC) and WEEE (2002/96/EC) directives.

Pletronics Inc. guarantees the device does not contain the following:
 Cadmium, Hexavalent Chromium, Lead, Mercury, PBB's, PBDE's
 Weight of the Device: 6.2 grams
 Moisture Sensitivity Level: 1 As defined in J-STD-020C
 Second Level Interconnect code: e1

Absolute Maximum Ratings:

Parameter	Unit
V _{CC} Supply Voltage	-0.5V to +7.0V
V _i Input Voltage	-0.5V to V _{CC} + 0.5V
V _o Output Voltage	-0.5V to V _{CC} + 0.5V

Reliability: Environmental Compliance

Parameter	Condition
Vibration	10 to 2000 Hz / 10 g
Shock	2000 g, 0.3 mS, ½ sine
Solderability	MIL-STD-883 Method 2003
Thermal Shock	MIL-STD-883 Method 1011, Condition A



OHM4 Series 5.0V CMOS Oven Controlled Oscillators

October 2007

Part Number:

OHM4048052 G G 010 040 -20.00M -XX

OHM4048052 G G 010 040 -20.00M -XX	Internal code or blank
	Frequency MHz (standards Shown) 10.000 12.800 16.000 16.384 19.440 20.000 32.768 40.000
	Electronic Frequency Control 000 = No EFC 020 = ± 2.0 ppm minimum 040 = ± 4.0 ppm minimum 150 = ± 15.0 ppm minimum 999 = ± 4.0 ppm with 0 to 10K ohm
	Frequency Stability 003 = ± 25 ppb for 0°C to 60°C 008 = ± 75 ppb for 0°C to 60°C 005 = ± 50 ppb for -20°C to 70°C 015 = ± 150 ppb for -20°C to 70°C 010 = ± 100 ppb for -40°C to 85°C 025 = ± 250 ppb for -40°C to 85°C
	Upper Operating Temperature C = 50°C F = 65°C J = 80°C D = 55°C G = 70°C K = 85°C E = 60°C H = 75°C L = 90°C
	Lower Operating Temperature A = 10°C D = -5°C G = -20°C J = -30°C B = 5°C E = -10°C H = -25°C K = -35°C C = 0°C F = -15°C I = -30°C L = -40°C
Series Model	

Part Marking:

PLE
OHM4050c
fff.fff M
ymdannn

Where: **c** = N for no EFC, R for resistor, V for voltage
fff.fff = Frequency in MHz
Ymday = Date code (Year Month Day plus internal code)
nnn = Device number

Standard values are listed, consult Pletronics Inc. for other options. Specifications such as frequency stability and operating temperature range, etc. are not identified from the marking. External packaging labels and packing list will correctly identify the ordered Pletronics part number.

Codes for Date Code YMD

Code	6	7	8	9	0	1	2
Year	2006	2007	2008	2009	2010	2011	2012

Code	A	B	C	D	E	F	G	H	J	K	L	M
Month	JAN	FEB	MAR	APR	MAY	JUN	JUL	AUG	SEP	OCT	NOV	DEC

Code	1	2	3	4	5	6	7	8	9	A	B	C
Day	1	2	3	4	5	6	7	8	9	10	11	12
Code	D	E	F	G	H	J	K	L	M	N	P	R
Day	13	14	15	16	17	18	19	20	21	22	23	24
Code	T	U	V	W	X	Y	Z					
Day	25	26	27	28	29	30	31					

Specification for 5.00V $\pm 0.20V$ over the specified temperature range

Item	Min	Max	Unit	Condition	
Frequency Range	10	40	MHz	See list of standard frequencies	
Frequency Accuracy vs. Temperature	250	± 250	ppb	determined by part number	
Frequency Accuracy vs. Supply	-100	+100	ppb	for Supply change of 0.2V	
Frequency Accuracy vs. Load	-10	+10	ppb	Load change of $\pm 10\%$	
Frequency Accuracy Short Term	-0.5	+0.5	ppb	for periods of 0.1 seconds to 30 seconds	
Aging 1 st Year	-0.70	+0.70	ppm		
10 Years	-4.0	+4.0	ppm	Accumulated for 10 years	
Frequency Control Voltage	-4.0	+4.0	ppm	0.5V to 5.0V, determined by part number > 47 K ohm	
(positive slope) Resistance	-4.0	+4.0	ppm	0 to 10 Kohm, determined by part number > 4.7 K ohm	
Phase Noise 1 Hz	--	-70	dBc/Hz		
10 Hz	--	-100			
100 Hz	--	-130			
1,000Hz	--	-140			
Warmup	--	30	sec	within specification after turn on at 0°C	
Output Waveform	CMOS				
Output High Level	0.4	--	V	Below V_{CC}	See Load Circuit Clod = 15 pF
Output Low Level	--	0.4	V		
Output Symmetry	40	60	%	at 50% of V_{CC}	
T_{rise} and T_{fall}	--	7	nS	10% to 90% of V_{CC}	
Power Supply Current	--	110	mA	at -20°C	
	--	70	mA	at +30°C	
Warmup	--	250	mA	for 10 seconds maximum	
Operating Temperature Range	-40	+85	°C	Part number defines the temperature range to meet the accuracy specification	
Storage Temperature Range	-55	+125	°C		

Load Circuit and Test Waveform

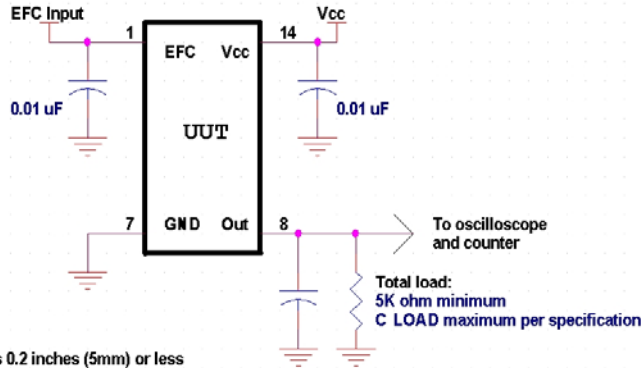

All leads 0.2 inches (5mm) or less

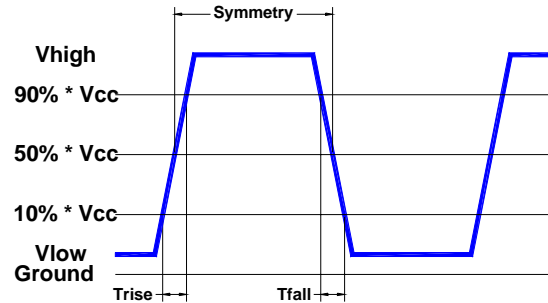

ESD Rating

Model	Minimum Voltage	Conditions
Human Body Model	2000	MIL-STD-883 Method 3115
Charged Device Model	2000	JESD 22-C101

Package Labeling

Label is 1" x 2.6" (25.4mm x 66.7mm)
Font is Courier New
Bar code is 39-Full ASCII

Label is 1" x 2.6" (25.4mm x 66.7mm)
Font is Arial

P/N:	
	OHM4048052GG010040-20.00M
Customer P/N:	
	12345678
Qty:	
	1000
D/C	
	0510M012

RoHS Compliant
2nd LvL Interconnect Category=e1
Max Safe Temp=250C for 10s Per Lead
Hand Solder Recommended

PCB Mounting (typical for lead free processing)

Hand soldering is recommended at 245°C ± 5°C for 5 seconds maximum per pin

Mechanical:

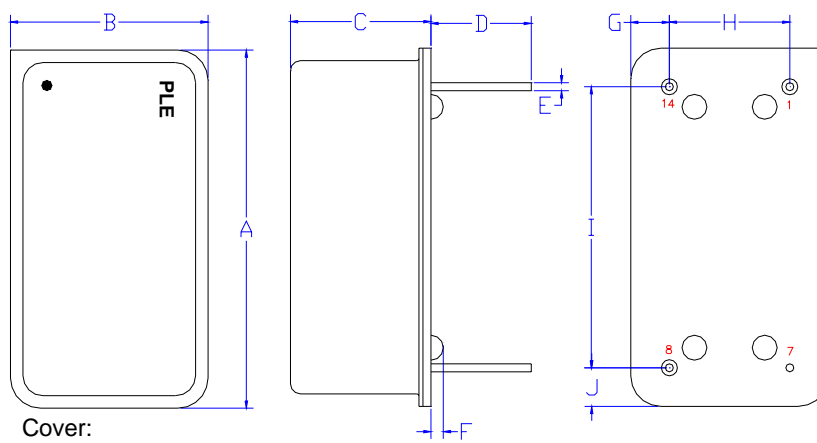

Cover:
Kovar
Electroless Nickel Plated
1 μinch (25 μm) typical
Resistance welded to base

Base:
Kovar
Glass to metal sealed leads

Label:
Laser Engraved – or –

Pin 7 Connected to case

White Kapton with Black Letters

Not to scale

	Inches	mm
A	0.800 ±0.005	20.3 max
B	0.52 ±0.005	13.2 max
C	0.315 max	8.00 max
D ¹	0.250	6.35
E ¹	0.020	0.51
F ¹	0.040 max	1.0 max
G ¹	0.110	2.79
H	0.300	7.62
I ¹	0.600	15.24
J ¹	0.100	2.53

¹ Nominal dimension

Pin	Function	Note
1	EFC	10 K ohm to ground –OR– 0.5 to 5.0V control voltage, depends on option ordered. Use the 30% value for initial operation
7	Ground (GND)	
8	Output	
14	Supply Voltage (V _{CC})	Recommend connecting appropriate power supply bypass capacitors as close as possible.

Layout and application information

For Optimum Jitter Performance, Pletronics recommends:

- Minimize air flow over the oscillator
- Stabilize the power supply voltage for best performance.

IMPORTANT NOTICE

Pletronics Incorporated (PLE) reserves the right to make corrections, improvements, modifications and other changes to this product at anytime. PLE reserves the right to discontinue any product or service without notice. Customers are responsible for obtaining the latest relevant information before placing orders and should verify that such information is current and complete. All products are sold subject to PLE's terms and conditions of sale supplied at the time of order acknowledgment.

PLE warrants performance of this product to the specifications applicable at the time of sale in accordance with PLE's limited warranty. Testing and other quality control techniques are used to the extent PLE deems necessary to support this warranty. Except where mandated by specific contractual documents, testing of all parameters of each product is not necessarily performed.

PLE assumes no liability for application assistance or customer product design. Customers are responsible for their products and applications using PLE components. To minimize the risks associated with the customer products and applications, customers should provide adequate design and operating safeguards.

PLE products are not designed, intended, authorized or warranted to be suitable for use in life support applications, devices or systems or other critical applications that may involve potential risks of death, personal injury or severe property or environmental damage. Inclusion of PLE products in such applications is understood to be fully at the risk of the customer. Use of PLE products in such applications requires the written approval of an appropriate PLE officer. Questions concerning potential risk applications should be directed to PLE.

PLE does not warrant or represent that any license, either express or implied, is granted under any PLE patent right, copyright, artwork or other intellectual property right relating to any combination, machine or process which PLE product or services are used. Information published by PLE regarding third-party products or services does not constitute a license from PLE to use such products or services or a warranty or endorsement thereof. Use of such information may require a license from a third party under the patents or other intellectual property of the third party, or a license from PLE under the patents or other intellectual property of PLE.

Reproduction of information in PLE data sheets or web site is permissible only if the reproduction is without alteration and is accompanied by associated warranties, conditions, limitations and notices. Reproduction of this information with alteration is an unfair and deceptive business practice. PLE is not responsible or liable for such altered documents.

Resale of PLE products or services with statements different from or beyond the parameters stated by PLE for that product or service voids all express and implied warranties for the associated PLE product or service and is an unfair or deceptive business practice. PLE is not responsible for any such statements.

Contacting Pletronics Inc.

Pletronics Inc.
19013 36th Ave. West
Lynnwood, WA 98036-5761 USA

Tel: 425-776-1880
Fax: 425-776-2760
E-mail: ple-sales@pletronics.com
URL: www.pletronics.com

Copyright © 2006, 2007, Pletronics Inc.