

UNLESS OTHERWISE NOTED

DIMENSIONS ARE IN INCHES	TOLERANCES ARE:	TITLE: HIGH TEMP 2mm TERMINAL STRIP (BOARD STACKING)
ONE PLACE DECIMALS ±.1[2.54mm]	THREE PLACE DECIMALS ± .005[.13mm]	DWG NO: YTW-XX-XX-XXX-X-XXX-XXX-XXX-XX SHEET 1 OF 3
TWO PLACE DECIMALS ±.01[.25mm]	FOUR PLACE DECIMALS ± .002[.05mm]	

ANGLES ± 5°

		TABLE 1	
		OVERALL LENGTH	
LEAD STYLE	TERMINAL	INCHES	MILLIMETERS
-01	T-1S13-20-XXX-2	.3228	8.0 mm
-02	T-1S13-02-XXX-2	.3770	9.6 mm
-03	T-1S13-03-XXX-2	.5347	13.6 mm
-04	T-1S13-06-XXX-2	.5550	14.01 mm
-05	T-1S13-09-XXX-2	.5940	15.10 mm
-06	T-1S13-10-XXX-2	.6730	17.10 mm
-07	T-1S13-11-XXX-2	.7510	19.10 mm
-09	T-1S13-13-XXX-2	.4560	11.60 mm
-10	T-1S13-14-XXX-2	.6140	15.60 mm
-11	T-1S13-05-XXX-2	.3970	10.08 mm

YTW-XX-XX-XXX-X-XXX-XXX-XXX-XX

No. OF POSITIONS
EXPRESSED IN # OF POS.
-02 THRU -50
"XX" = No. OF POS. X .07874 [2.00]

LEAD STYLE
(SEE TABLE 1)
(SEE *NOTE)

PLATING

- G: GOLD (SPECIFY -G IN T-1S13-XX-G-2)
- T: TIN (SPECIFY -T IN T-1S13-XX-T-2)
- S: SELECTIVE (SPECIFY -S IN T-1S13-XX-S-2)
- L: SELECTIVE (SPECIFY -L IN T-1S13-XX-L-2)
- TL: TIN/LEAD (SPECIFY -TL IN T-1S13-XX-TL-2)
- F: FLASH GOLD (SPECIFY -F IN T-1S13-XX-F-2)
- H: HEAVY GOLD (SPECIFY -H IN T-1S13-XX-H-2)
- LTL: LIGHT SELECTIVE TIN/LEAD (SPECIFY -LTL IN T-1S13-XX-LTL-2)
- STL: SELECTIVE TIN/LEAD (SPECIFY -STL IN T-1S13-XX-STL-2)
- TM: MATTE TIN (SPECIFY -T IN T-1S13-XX-T-2)
- SM: HEAVY SELECTIVE GOLD, MATTE TIN TAIL (SPECIFY -S IN T-1S13-XX-S-2)
- LM: LIGHT SELECTIVE GOLD, MATTE TIN TAIL (SPECIFY -L IN T-1S13-XX-L-2)
- FM: FLASH SELECTIVE GOLD, MATTE TIN TAIL (SPECIFY -F IN T-1S13-XX-F-2)

OPTION
** -MW: METAL WASHER
(SEE FIG. 2, SHT. 3)
(.300 [7.62] MAX TAIL)
(.090 [2.27] MIN. TAIL)

POLARIZATION OPTION
SPECIFY POS. TO BE REMOVED
(SEE FIGURE 1)

TAIL LENGTH

SPACE OPTION
-Q: (.120 MIN.)
-5, -6: (.160 MIN.)
MAX = 'L' - .050

ROW OPTION
-Q: QUAD (USE BODY TMM-50-Q: .120-.160 BOARD SPACE)
(ABOVE .160 BOARD SPACE, USE BODY TMMH-50-Q)
-5: FIVE ROW (USE BODY TMMH-50-5)
-6: SIX ROW (USE BODY TMMH-50-6)

**** - MW OPTION, DO NOT DESIGN IN. SAMTEC WILL ONLY SUPPORT EXISTING BUSINESS 2/11/02.**

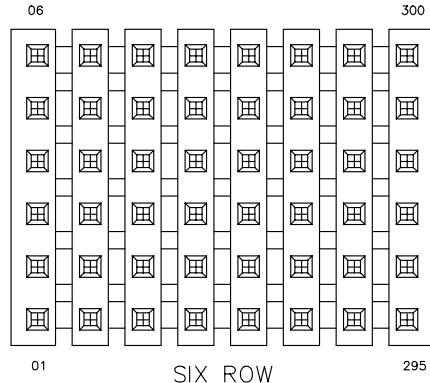
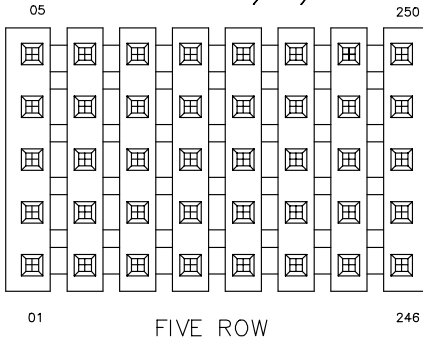
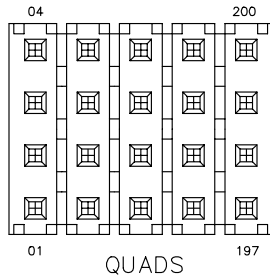

FIG. 1
SCALE: .75x
(SEE NOTE 6)

PACKAGING TUBE TABLE
(SEE NOTE 9)

LEAD STYLE	ROW	PACKAGING TUBE	PLUG
-01, -02, -11	Q	PT-1-24-02-70	TP-29
-03, -04	Q	PT-1-24-02-75	TP-07
-06, -07	Q	PT-1-24-01-67	TP-13
-05, -10	Q	PT-1-24-02-08	TP-13
-01, -02	6	PT-1-24-01-70	TP-29
-03, -04	6	PT-1-24-01-75	TP-13
-05, -06, -10	6	PT-1-24-01-91	TP-29
-07	6	PT-1-24-02-74	TP-13
-09, -11	6	PT-1-24-01-08	TP-13
-01, -02, -11	5	PT-1-24-01-70	TP-29
-03, -04, -05, -09, -10	5	PT-1-24-04-101	TP-29
-06, -07	5	PT-1-24-03-60	TP-29

- NOTES:
- 1.) MAX ALLOWABLE BOW: .005 IN/IN AFTER ASSEMBLY.
 - 2.) MAX PIN ROTATION IN BODY: 2°.
 - 3.) PUSHOUT FORCE SHALL BE 1 lb. MIN.
 - 4.) (⊙) REPRESENTS A CRITICAL DIMENSION.
 - 5.) ON SELECTIVELY PLATED PARTS, GOLD AREA TO APPEAR ON POST.
 - 6.) TOP VIEW (VIEW OF CONTACT AREA, OPPOSITE VIEW OF CUSTOMER SPECIFIED TAIL (SEE PAGE 2)).
 - 7.) .020 MAX FLASH
 - 8.) MUST USE CARBIDE BLADES.
 - 9.) ONLY -MW OPTION TO BE TUBED.

PLOT SCALE 1=11

PROPRIETARY NOTE
THIS DOCUMENT CONTAINS INFORMATION CONFIDENTIAL AND PROPRIETARY TO SAMTEC INC. AND SHALL NOT BE REPRODUCED OR TRANSFERRED TO OTHER DOCUMENTS OR DISCLOSED TO OTHERS OR USED FOR ANY PURPOSE OTHER THAN THAT FOR WHICH IT WAS OBTAINED WITHOUT THE EXPRESSED WRITTEN CONSENT OF SAMTEC INC.

MATERIAL:

TMM BODY:
LCP
COLOR: BLACK

TMMH BODY:
LCP
COLOR: BLACK

TERMINALS:
PHOSPHOR BRONZE

EXISPROD\ASSEMBLY\2MM
YTWSM1

samtec

520 PARK EAST BLVD. NEW ALBANY, INDIANA 47150
PHONE (812) 944-6733 P.O. BOX 1147
CODE 55322

MADE BY:
BRYANT 02/09/99

YTW-XX-XX-XXX-X-XXX-XXX-XXX-XX
SHEET 1 OF 3

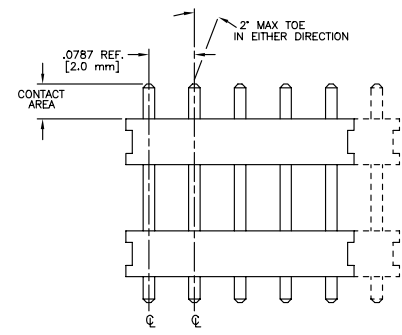
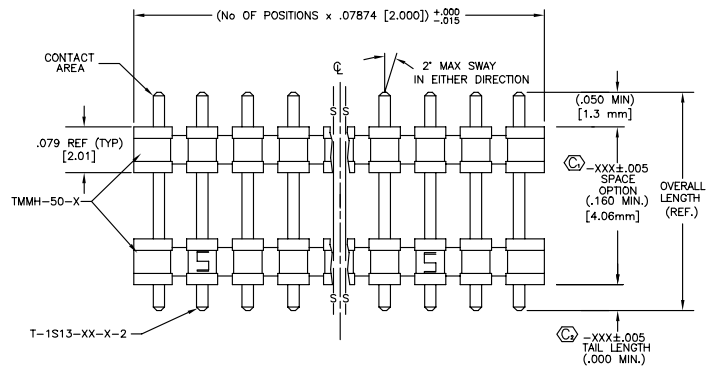

-5: FIVE ROW
-6: SIX ROW

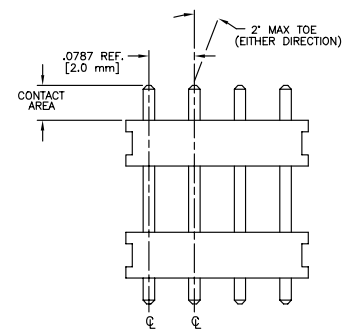
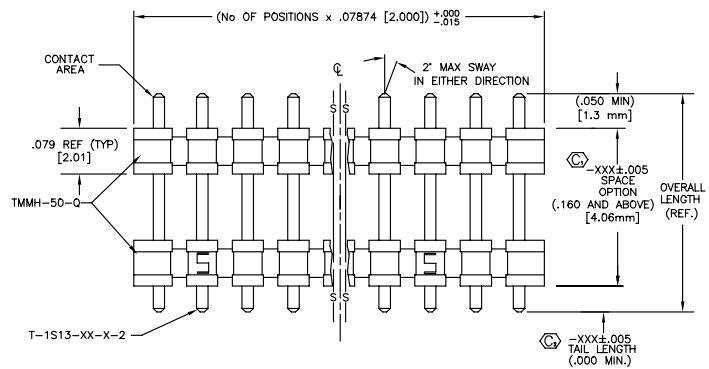

-Q: QUAD

Do not scale from this print

PROPRIETARY NOTE
THIS DOCUMENT CONTAINS INFORMATION CONFIDENTIAL AND PROPRIETARY TO SAMTEC INC. AND SHALL NOT BE REPRODUCED OR TRANSFERRED TO OTHER DOCUMENTS OR DISCLOSED TO OTHERS OR USED FOR ANY PURPOSE OTHER THAN THAT FOR WHICH IT WAS OBTAINED WITHOUT THE EXPRESSED WRITTEN CONSENT OF SAMTEC INC.

PLOT SCALE 1=11

		MISC\MKTG YTWMKT2
520 PARK EAST BLVD. NEW ALBANY, INDIANA 47150 PHONE (812) 944-6733 P.O. BOX 1147 CODE 55322		
MADE BY: BRYANT 02/09/99	YTW-XX-XX-X-X-XXX-XXX-XXX-XX SHEET 2 OF 3	

REV. H

.0900 [2.287]
(MIN. TAIL)

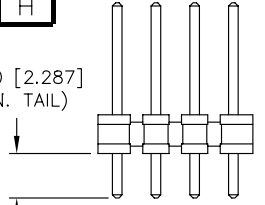

IN PROCESS 1

.0900 [2.287]
.007 MAX [.178]

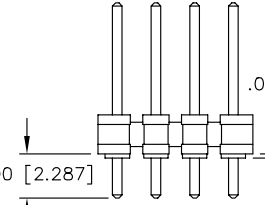

IN PROCESS 2

RE-PRESS TO
DESIRED TAIL (.300 MAX)

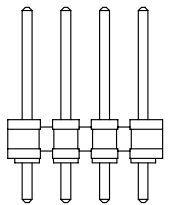

IN PROCESS 3

MOUNT
STACKER
BODY

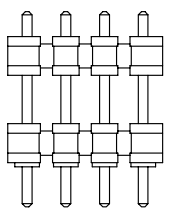

IN PROCESS 4

DIMENSIONS ARE IN INCHES		UNLESS OTHERWISE NOTED	
TOLERANCES ARE:		ANGLES ± 2°	
ONE PLACE DECIMALS ± .1 [2.5]	THREE PLACE DECIMALS ± .005 [.13]		
TWO PLACE DECIMALS ± .01 [.25]	FOUR PLACE DECIMALS ± .0020 [.05]		

TITLE: 2mm
TERMINAL STRIP
ASSEMBLY

DWG NO: YTW-XX-XX-X-X-XXX-XXX-XXX-XX
SHEET 3 OF 3

FIG. 2
** -MW: METAL WASHER
(ONE PER POSITION)
(30 POS MAX)

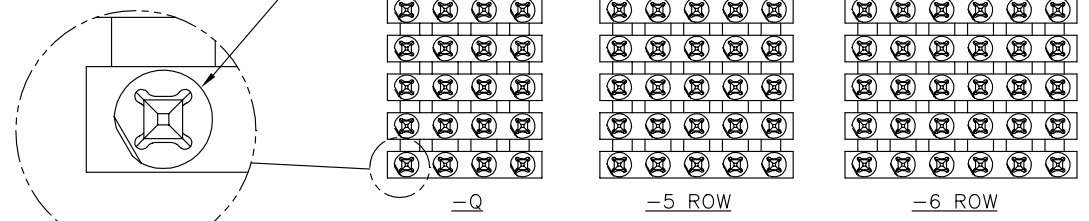
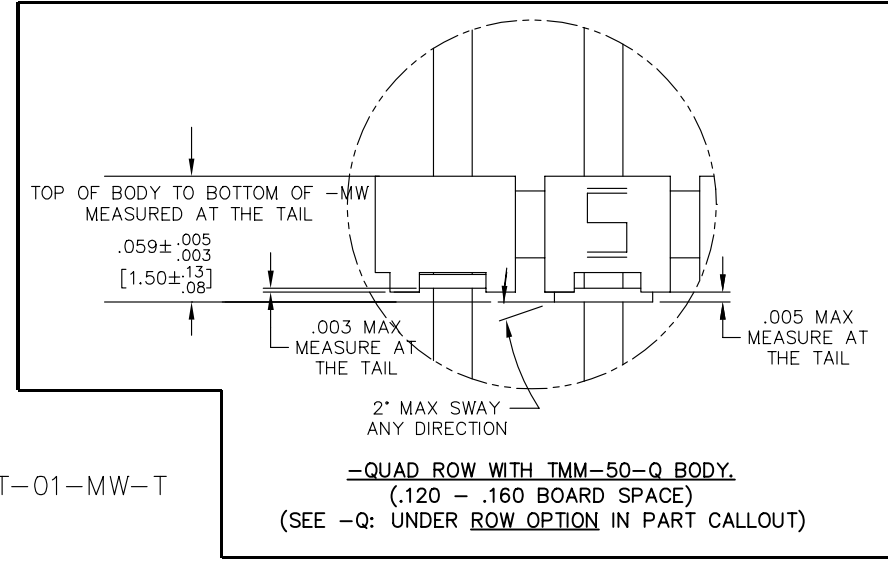
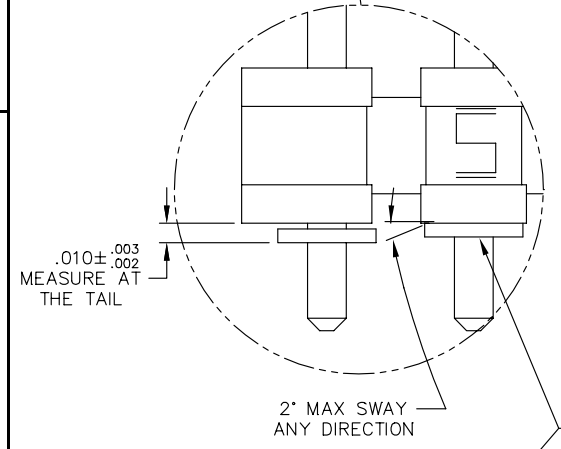
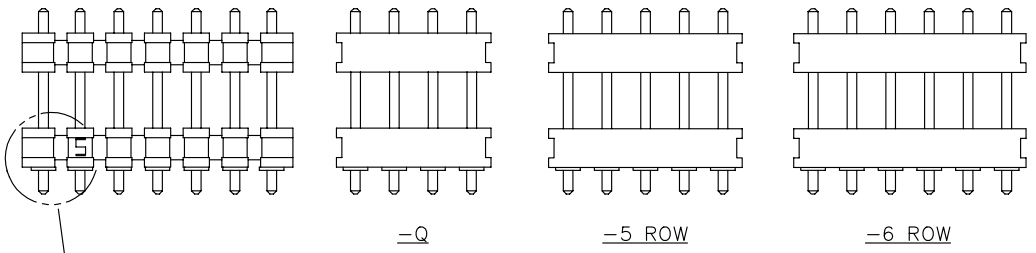

** - MW OPTION, DO NOT DESIGN IN. SAMTEC WILL ONLY SUPPORT EXISTING BUSINESS 2/11/02.

PROPRIETARY NOTE
THIS DOCUMENT CONTAINS INFORMATION CONFIDENTIAL AND PROPRIETARY TO SAMTEC INC. AND SHALL NOT BE REPRODUCED OR TRANSFERRED TO OTHER DOCUMENTS OR DISCLOSED TO OTHERS OR USED FOR ANY PURPOSE OTHER THAN THAT FOR WHICH IT WAS OBTAINED WITHOUT THE EXPRESSED WRITTEN CONSENT OF SAMTEC INC.

samtec

520 PARK EAST BLVD. NEW ALBANY, INDIANA 47150
PHONE (812) 944-6733 P.O. BOX 1147
CODE 55322

MISC\MKGT
YTWMKT3

MADE BY:
BRYANT 02/09/99

YTW-XX-XX-X-X-XXX-XXX-XXX-XX
SHEET 3 OF 3

PLOT SCALE 1=2