



Technical Specification
of
1.27 μ m~1.61 μ m MQW-DFB Laser Diode Module
for CWDM of 622Mb/s and 2.5Gb/s transmission

SLT4460-xx/RH2-xnnnx Series

RoHS Compliant



1. General

SLT4460-xx/RH2-xnnnx Series are 1.27 μ m~1.61 μ m InGaAsP/InP MQW-DFB laser diode modules designed for fiber optic communication systems. These modules are ideally suitable for CWDM of 622Mb/s or 2.5Gb/s transmission applications.

A laser diode is mounted into a coaxial package integrated with an InGaAs monitor PD, a single mode fiber pigtail and a single-stage isolator. The lead content of this isolator is less than 1000ppm.

2. Package dimension and pin assignment

(See attached appendix.)

3. Absolute maximum ratings

Parameter	Symbol	Ratings	Unit
Storage temperature	Tstg	-40~+85	°C
Operating case temperature	Top	0~+70	°C
Fiber output power	Pf	10	mW
Forward current (LD)	IfL	150	mA
Reverse voltage (LD)	VrL	2	V
Reverse voltage (PD)	VrP	15	V
Reverse current (PD)	IrP	2	mA
Soldering temperature (<10s)	Stemp	260	°C

4. Electrical and optical characteristics (Pf=2mW, Tc=+25°C, unless otherwise noted.)

Parameter	Symbol	Condition	Min.	Typ.	Max.	Unit
Threshold current	Ith	CW	—	10	20	mA
		CW, Tc=0~+70°C	—	—	50	
Optical output power	Pf	CW, If=Ith+20mA	1.0	2	3.0	mW
		CW, If=Ith+20mA, Tc=0~+70°C	0.6	—	5.0	
Operating voltage	Vf	CW, Tc=0~+70°C	—	—	1.7	V
Slope efficiency	Se	CW	0.05	—	0.15	mW/mA
		CW, Tc=0~+70°C	0.03	—	0.25	
Peak wavelength	λ_p	CW	(*1)			nm
Wavelength temperature coeff.	—	CW, Tc=0~+70°C	0.07	0.1	0.12	nm/°C
Side-mode suppression ratio	SSR	CW, Tc=0~+70°C	30	—	—	dB
Tracking error	ΔPf	Im hold(@Pf=2mW(+25°C)), CW Tc=0~+70°C	-1.0	—	1.0	dB
Rise time	tr	Ib=Ith, 20-80%, Tc=0~+70°C	—	0.05	0.10	ns
Fall time	tf	Ib=Ith, 80-20%, Tc=0~+70°C	—	0.10	0.15	ns
Extinction ratio	Er	10log(2mW/Pf(Ith)), Tc=0~+70°C	10	—	—	dB
Monitor current	Im	CW, VrP=5V, Tc=0~+70°C	50	—	1500	μ A
Monitor dark current	Id	VrP=5V	—	1	10	nA
Monitor capacitance	C	VrP=5V, f=1MHz	—	—	10	pF

Note: *1. Detail of peak wavelength specification

Rank A				Rank B					
Channel No.	Min.	Typ.	Max.	Unit	Channel No.	Min.	Typ.	Max.	Unit
-K605A	1268	1270	1272	nm	-K605B	1267	1270	1273	nm
-K240A	1288	1290	1292		-K240B	1287	1290	1293	
-J885A	1308	1310	1312		-J885B	1307	1310	1313	
-J540A	1328	1330	1332		-J540B	1327	1330	1333	
-J205A	1348	1350	1352		-J205B	1347	1350	1353	
-H885A	1368	1370	1372		-H885B	1367	1370	1373	
-H570A	1388	1390	1392		-H570B	1387	1390	1393	
-H260A	1408	1410	1412		-H260B	1407	1410	1413	
-G965A	1428	1430	1432		-G965B	1427	1430	1433	
-G675A	1448	1450	1452		-G675B	1447	1450	1453	
-G390A	1468	1470	1472		-G390B	1467	1470	1473	
-G120A	1488	1490	1492		-G120B	1487	1490	1493	
-F850A	1508	1510	1512		-F850B	1507	1510	1513	
-F590A	1528	1530	1532		-F590B	1527	1530	1533	
-F340A	1548	1550	1552		-F340B	1547	1550	1553	
-F095A	1568	1570	1572		-F095B	1567	1570	1573	
-E855A	1588	1590	1592		-E855B	1587	1590	1593	
-E620A	1608	1610	1612		-E620B	1607	1610	1613	

5. Fiber pigtail specification

Parameter	Min.	Typ.	Max.	Unit
Type	Single Mode			—
Mode field diameter@1310nm	8.5	9.5	10.5	μm
Cladding diameter	122	125	128	μm
Outer jacket diameter	0.8	0.9	1.0	mm
Bending radius	30	—	—	mm

6. Ordering Information

Part Number for RoHS compliance	Pin assignment	Optical isolator	Connector type	Flange type (hole pitch)	
SLT4460-CP/RH2-xnnnx	Type A	Single-stage isolator	SC/PC	Vertical (12mm)	
SLT4460-CS/ RH2-xnnnx				Horizontal (12.7mm)	
SLT4460-CN/ RH2-xnnnx				Flangeless	
SLT4460-XP/ RH2-xnnnx			No connector	Vertical (12mm)	
SLT4460-XS/ RH2-xnnnx				Horizontal (12.7mm)	
SLT4460-XN/ RH2-xnnnx				Flangeless	
SLT4466-CP/ RH2-xnnnx	Type C		Single-stage isolator	SC/PC	Vertical (12mm)
SLT4466-CS/ RH2-xnnnx					Horizontal (12.7mm)
SLT4466-CN/ RH2-xnnnx					Flangeless
SLT4466-XP/ RH2-xnnnx				No connector	Vertical (12mm)
SLT4466-XS/ RH2-xnnnx					Horizontal (12.7mm)
SLT4466-XN/ RH2-xnnnx					Flangeless

Channel (-xnnnx)	$\lambda_p@25^\circ\text{C}$	Range
-K605A	1270nm	$\pm 2\text{nm}$
-K605B		$\pm 3\text{nm}$
-K240A	1290nm	$\pm 2\text{nm}$
-K240B		$\pm 3\text{nm}$
-J885A	1310nm	$\pm 2\text{nm}$
-J885B		$\pm 3\text{nm}$
-J540A	1330nm	$\pm 2\text{nm}$
-J540B		$\pm 3\text{nm}$
-J205A	1350nm	$\pm 2\text{nm}$
-J205B		$\pm 3\text{nm}$
-H885A	1370nm	$\pm 2\text{nm}$
-H885B		$\pm 3\text{nm}$
-H570A	1390nm	$\pm 2\text{nm}$
-H570B		$\pm 3\text{nm}$
-H260A	1410nm	$\pm 2\text{nm}$
-H260B		$\pm 3\text{nm}$
-G965A	1430nm	$\pm 2\text{nm}$
-G965B		$\pm 3\text{nm}$
-G675A	1450nm	$\pm 2\text{nm}$
-G675B		$\pm 3\text{nm}$
-G390A	1470nm	$\pm 2\text{nm}$
-G390B		$\pm 3\text{nm}$
-G120A	1490nm	$\pm 2\text{nm}$
-G120B		$\pm 3\text{nm}$
-F850A	1510nm	$\pm 2\text{nm}$
-F850B		$\pm 3\text{nm}$
-F590A	1530nm	$\pm 2\text{nm}$
-F590B		$\pm 3\text{nm}$
-F340A	1550nm	$\pm 2\text{nm}$
-F340B		$\pm 3\text{nm}$
-F095A	1570nm	$\pm 2\text{nm}$
-F095B		$\pm 3\text{nm}$
-E855A	1590nm	$\pm 2\text{nm}$
-E855B		$\pm 3\text{nm}$
-E620A	1610nm	$\pm 2\text{nm}$
-E620B		$\pm 3\text{nm}$

7. Precaution

- (1) Radiation emitted by laser devices can be dangerous to the eyes. Avoid eye or skin exposure to direct or scattered radiation.
- (2) The modules should be handled in the same manner as ordinary semiconductor devices to prevent the electro-static damages. For safe keeping and carrying, the modules should be packaged with ESD proof material. To assemble the modules on PCB, the workbench, the soldering iron and the human body should be grounded.
- (3) The stress to the fiber pigtail may cause the damage on the performance. The fiber pigtail may snap off by dropping the module.
- (4) Please pay special attention to the atmosphere condition because the dew on the module may cause some electrical damages.
- (5) Under such a strong vibration environment as in automobile, the performance and reliability are not guaranteed.

8. RoHS Compliancy

On January 27, 2003, the European Parliament and the Council of the European Union issued the directive 2002/95/EC on the restriction of the use of certain hazardous substances in electrical and electronic equipment (RoHS).

Member States shall ensure that, from July 1, 2006, new electrical and electronic equipment put on the market does not contain lead, mercury, cadmium, hexavalent chromium, polybrominated biphenyls (PBB) or polybrominated diphenyl ethers (PBDE).

Applications listed in the Annex are exempted.

This product is compliant with RoHS 6/6 directive with exemptions "Lead in glass of cathode ray tubes, electronic components and fluorescent tubes" and "Lead as an alloying element in steel containing up to 0.35 % lead by weight, aluminium containing up to 0.4 % lead by weight and as a copper alloy containing up to 4 % lead by weight".

Appendix

Part No.: SLT446□-□□□ / □□□□-□□□□□□□□□□
 (RH2 or Customize Code)

Code	Connector type
C	SC/PC
D	FC/PC
L	LC/PC
M	MU/PC
Q	SC/Angled PC
X	No connector

Code	Flange type
N	Flangeless
P	Vertical (12.0mm)
S	Horizontal (12.7mm)

Code	Pin assignment
0	Type A
6	Type C

Pin No.	Pin function for type A
1	LD anode (CASE)
2	LD cathode
3	PD cathode
4	PD anode

Code	Wavelength range
A	±2nm
B	±3nm

Pin No.	Pin function for type C
1	(CASE)
2	LD cathode
3	PD anode
4	LD anode/ PD cathode

Channel	Wavelength @25deg.C
-K605	1270nm
-K240	1290nm
-J885	1310nm
-J540	1330nm
-J205	1350nm
-H885	1370nm
-H570	1390nm
-H260	1410nm
-G965	1430nm
-G675	1450nm
-G390	1470nm
-G120	1490nm
-F850	1510nm
-F590	1530nm
-F340	1550nm
-F095	1570nm
-E855	1590nm
-E620	1610nm

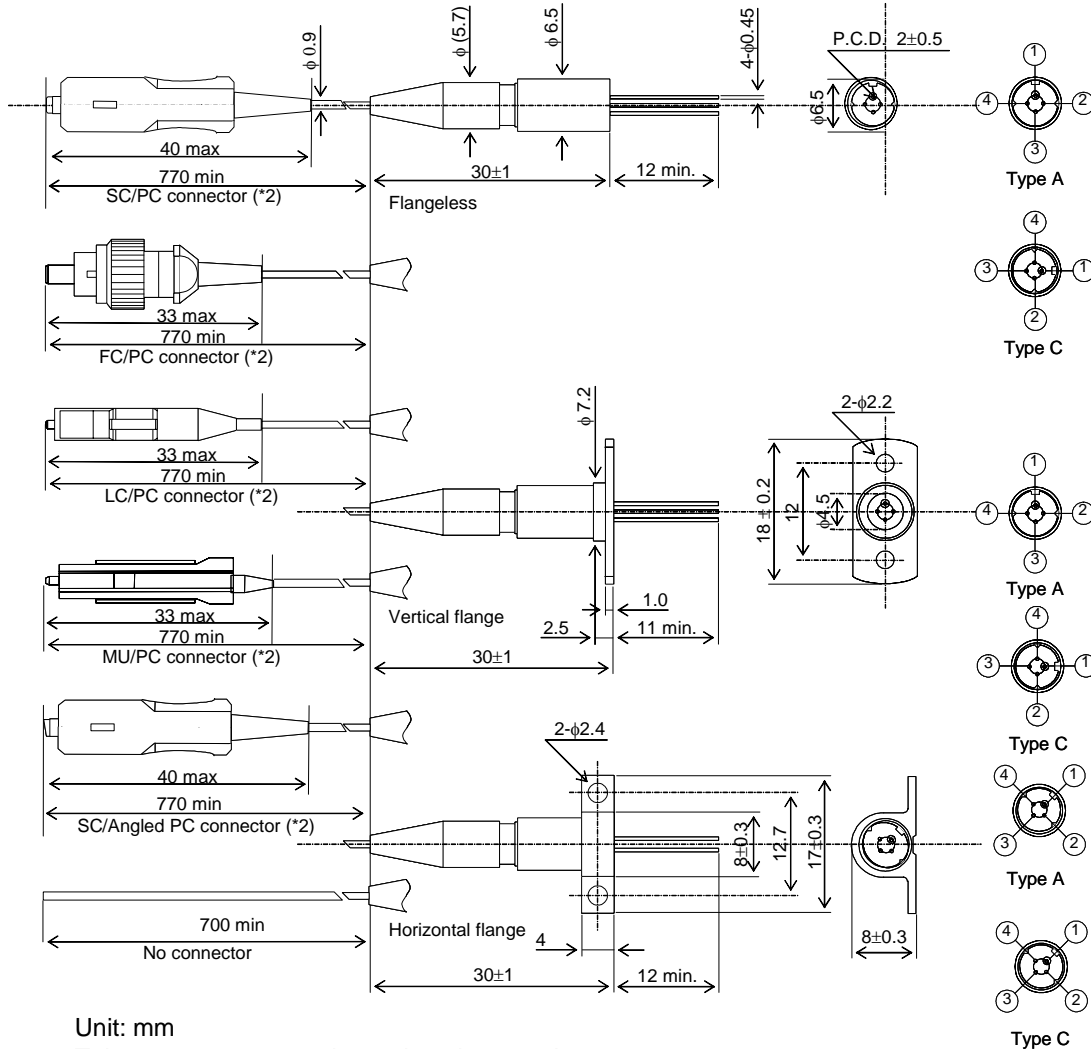

Note: *2. IEC and JIS compliant. Detailed design not specified in the IEC and JIS standards is a subject to change without notice.

9. For More Information

U.S.A.

ExceLight Communications Inc.

4021 Stirrup Creek Drive, Suite 200, Durham NC, 27703

U.S.A.

Tel. (919) 361-1600

Fax. (919) 361-1619

E-mail: info@excelight.com

URL: <http://www.excelight.com>

Europe

Sumitomo Electric Europe Ltd.

220 Centennial Park, Centennial Avenue, Elstree, Herts, WD6 3SL

United Kingdom

Tel. (020) 8953-8118

Fax. (020) 8207-5950

URL: <http://www.sumielectric.com>

Japan

Sumitomo Electric Industries, Ltd. (Opto-electronic Products Sales Dept.)

3-12, Moto-Akasaka 1-chome, Minato-ku Tokyo, 107-8468

Japan

Tel. (03) 3423-5031

Fax. (03) 3423-5247

E-mail: product_info@ppd.sei.co.jp

URL: http://www.sei.co.jp/Electro-optic/index_e.html

Revision Record

Document No.	Date of issue	Description	Incorporated by	Checked by	Approved by
HUW0724107-01A	Jan./14/08	Initial issue.	Y. Yamasaki	T. Takagi N. Fukushima	H. Michikoshi