

PREPARED BY:      DATE	<b>SHARP</b>	SPEC No. LD- K21505
APPROVED BY:      DATE		FILE No.
		ISSUE: May, 25, 2009
		PAGE : 24pages
	AVC LIQUID CRYSTAL DISPLAY GROUP SHARP CORPORATION SPECIFICATION	MODULE DEVELOPMENT CENTER AVC LIQUID CRYSTAL DISPLAY GROUP

**DEVICE SPECIFICATION FOR**

**TFT-LCD module**

**Model No. LK460D3LA28**

CUSTOMER'S APPROVAL

DATE \_\_\_\_\_

PRESENTED

BY \_\_\_\_\_

BY T. Suzuki

T.SUZUKI  
General manager  
MODULE DEVELOPMENT CENTER  
AVC LIQUID CRYSTAL DISPLAY GROUP  
SHARP CORPORATION



## 1. Application

This specification applies to the color 46.0" TFT-LCD module LK460D3LA28.

- \* This specification is proprietary products of SHARP CORPORATION ("SHARP") and include materials protected under copyright of SHARP. Do not reproduce or cause any third party to reproduce them in any form or by any means, electronic or mechanical, for any purpose, in whole or in part, without the express written permission of SHARP.
- \* In case of using the device for applications such as control and safety equipment for transportation (aircraft, trains, automobiles, etc.), rescue and security equipment and various safety related equipment which require higher reliability and safety, take into consideration that appropriate measures such as fail-safe functions and redundant system design should be taken.
- \* Do not use the device for equipment that requires an extreme level of reliability, such as aerospace applications, telecommunication equipment (trunk lines), nuclear power control equipment and medical or other equipment for life support.
- \* SHARP assumes no responsibility for any damage resulting from the use of the device that does not comply with the instructions and the precautions specified in these specification.
- \* Contact and consult with a SHARP sales representative for any questions about this device.

## 2. Overview

This LCD module is a color active matrix LCD module incorporating amorphous silicon TFT (Thin Film Transistor). It is composed of a color TFT-LCD panel, driver ICs, control circuit, power supply circuit, inverter circuit and back light system etc. Graphics and texts can be displayed on a 1920×RGB×1080 dots panel with about one billion colors by using LVDS (Low Voltage Differential Signaling) to interface, +12V of DC supply voltages.

This LCD module also includes the DC/AC inverter to drive the CCFT. (+24V of DC supply voltage)

And in order to improve the response time of LCD, This LCD module applies the Over Shoot driving (O/S driving) technology for the control circuit. In the O/S driving technology, signals are being applied to the Liquid Crystal according to a pre-fixed process as an image signal of the present frame when a difference is found between image signal of the previous frame and that of the current frame after comparing them.

With this technology, image signals can be set so that liquid crystal response completes within one frame. As a result, motion blur reduces and clearer display performance can be realized.

## 3. Mechanical Specifications

Parameter	Specifications	Unit
Display size	116.8 (Diagonal)	cm
	46.0 (Diagonal)	inch
Active area	1018.08(H) x 572.67 (V)	mm
Pixel Format	1920(H) x 1080(V) (1pixel = R + G + B dot)	pixel
Pixel pitch	0.53025(H) x 0.53025 (V)	mm
Pixel configuration	R, G, B vertical stripe	
Display mode	Normally black	
Unit Outline Dimensions (*1)	1083.0(W) x 624.7(H) x 53.4(D)	mm
Mass	11.5 ±1.0	kg
Surface treatment	Low Haze Anti glare Haze value:8% Hard coating: 3H	

(\*1) Outline dimensions are shown in Fig.1 (excluding protruding portion)

## 4. Input Terminals

### 4.1. TFT panel driving

CN1 (Interface signals and +12V DC power supply) (Shown in Fig.1)

Using connector : FI-RE51S-HF (Japan Aviation Electronics Ind., Ltd.)

Matching connector : FI-RE51HL, FI-RE51CL (Japan Aviation Electronics Ind., Ltd.)

or equivalent device

Matching LVDS transmitter : THC63LVD1023 or equivalent device

Pin No.	Symbol	Function	Remark
1	GND		
2	Reserved	It is required to set non-connection(OPEN)	
3	Reserved	It is required to set non-connection(OPEN)	
4	Reserved	It is required to set non-connection(OPEN)	
5	Reserved	It is required to set non-connection(OPEN)	
6	Reserved	It is required to set non-connection(OPEN)	
7	SELLVDS	Select LVDS data order [Note2,3]	Pull UP : 3.3V
8	Reserved	It is required to set non-connection(OPEN)	
9	Reserved	It is required to set non-connection(OPEN)	
10	FRAME	Frame frequency setting 0:60Hz 1:50Hz [Note1]	Pull down : GND
11	GND		
12	AIN0-	Aport (-)LVDS CH0 differential data input	
13	AIN0+	Aport (+)LVDS CH0 differential data input	
14	AIN1-	Aport (-)LVDS CH1 differential data input	
15	AIN1+	Aport (+)LVDS CH1 differential data input	
16	AIN2-	Aport (-)LVDS CH2 differential data input	
17	AIN2+	Aport (+)LVDS CH2 differential data input	
18	GND		
19	ACK-	Aport LVDS Clock signal(-)	
20	ACK+	Aport LVDS Clock signal(+)	
21	GND		
22	AIN3-	Aport (-)LVDS CH3 differential data input	
23	AIN3+	Aport (+)LVDS CH3 differential data input	
24	AIN4-	Aport (-)LVDS CH4 differential data input	
25	AIN4+	Aport (+)LVDS CH4 differential data input	
26	GND		
27	GND		
28	BIN0-	Bport (-)LVDS CH0 differential data input	
29	BIN0+	Bport (+)LVDS CH0 differential data input	
30	BIN1-	Bport (-)LVDS CH1 differential data input	
31	BIN1+	Bport (+)LVDS CH1 differential data input	
32	BIN2-	Bport (-)LVDS CH2 differential data input	
33	BIN2+	Bport (+)LVDS CH2 differential data input	
34	GND		
35	BCK-	Bport LVDS Clock signal(-)	
36	BCK+	Bport LVDS Clock signal(+)	
37	GND		
38	BIN3-	Bport (-)LVDS CH3 differential data input	
39	BIN3+	Bport (+)LVDS CH3 differential data input	
40	BIN4-	Bport (-)LVDS CH4 differential data input	
41	BIN4+	Bport (+)LVDS CH4 differential data input	
42	GND		
43	GND		

44	GND		
45	GND		
46	GND		
47	VCC	+12V Power Supply	
48	VCC	+12V Power Supply	
49	VCC	+12V Power Supply	
50	VCC	+12V Power Supply	
51	VCC	+12V Power Supply	

[note] GND of a liquid crystal panel drive part has connected with a module chassis.

[Note 1] The equivalent circuit figure of the terminal

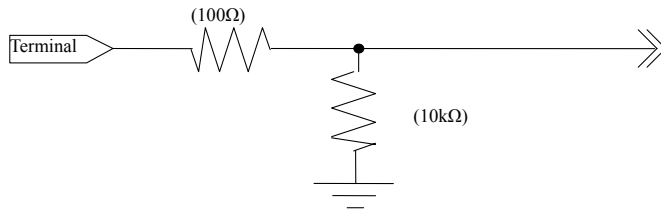

[Note 2] The equivalent circuit figure of the terminal

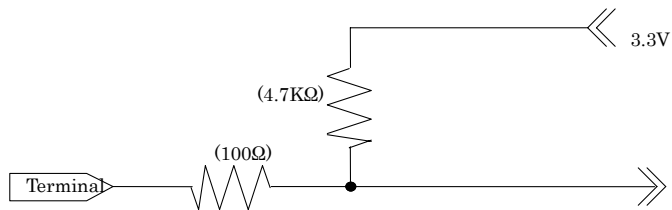

[Note 3] LVDS Data order

SELLVDS		
Data	L(GND)	H(3.3V) or Open
TA0	R0(LSB)	R4
TA1	R1	R5
TA2	R2	R6
TA3	R3	R7
TA4	R4	R8
TA5	R5	R9(MSB)
TA6	G0(LSB)	G4
TB0	G1	G5
TB1	G2	G6
TB2	G3	G7
TB3	G4	G8
TB4	G5	G9(MSB)
TB5	B0(LSB)	B4
TB6	B1	B5
TC0	B2	B6
TC1	B3	B7
TC2	B4	B8
TC3	B5	B9(MSB)
TC4	NA	NA
TC5	NA	NA
TC6	DE(*)	DE(*)
TD0	R6	R2
TD1	R7	R3
TD2	G6	G2
TD3	G7	G3
TD4	B6	B2
TD5	B7	B3
TD6	NA	NA
TE0	R8	R0(LSB)
TE1	R9(MSB)	R1
TE2	G8	G0(LSB)
TE3	G9(MSB)	G1
TE4	B8	B0(LSB)
TE5	B9(MSB)	B1
TE6	NA	NA

NA: Not Available

(\*)Since the display position is prescribed by the rise of DE(Display Enable)signal, please do not fix DE signal during operation at "High".

**SELLVDS= Low (GND)**

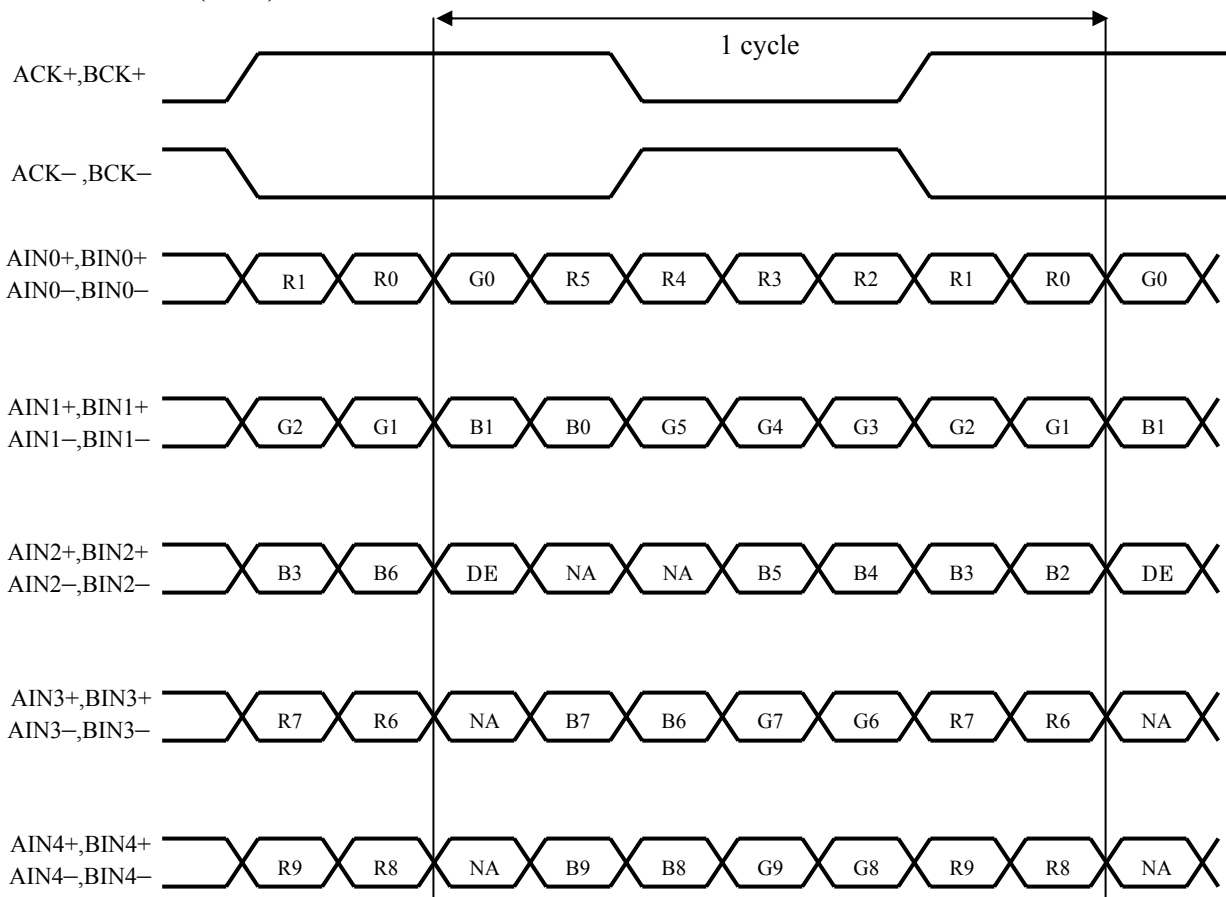

**SELLVDS= High (3.3V) or OPEN**

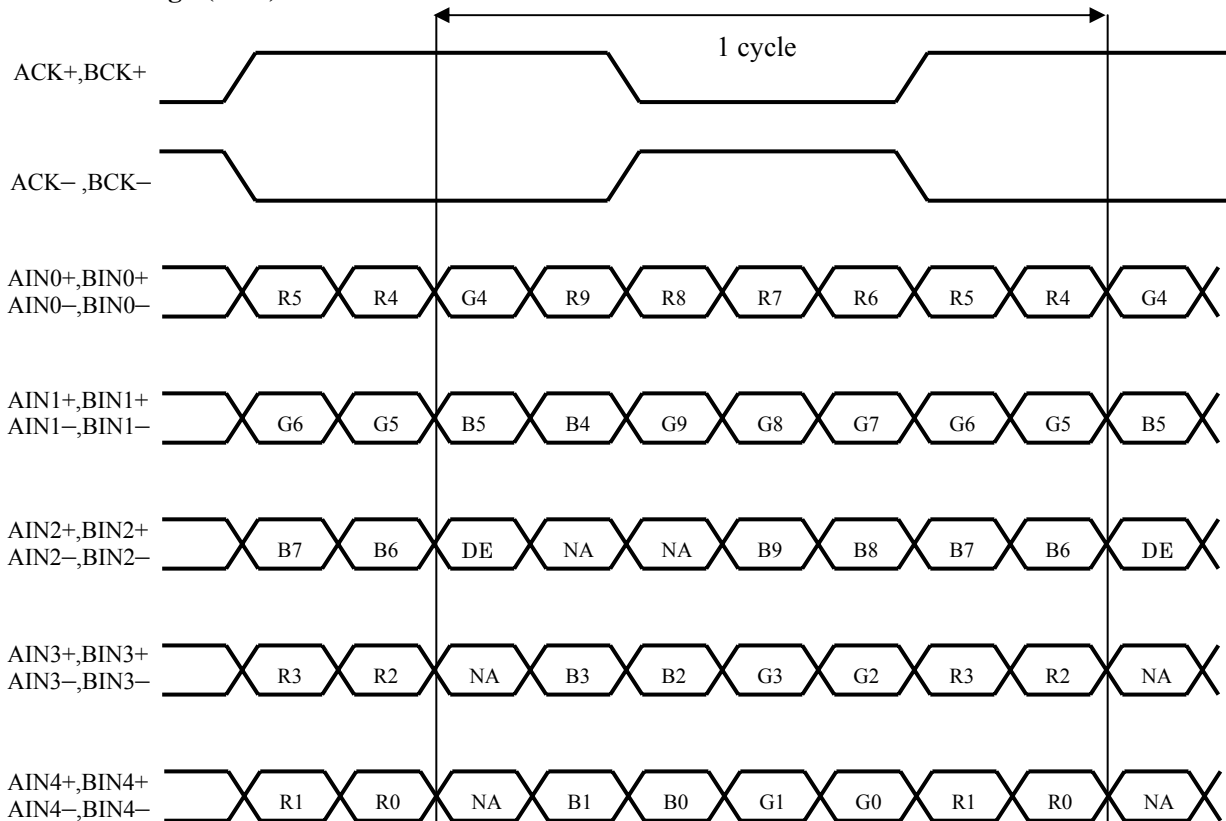

DE: Display Enable, NA: Not Available (Fixed Low)

4.2. Interface block diagram

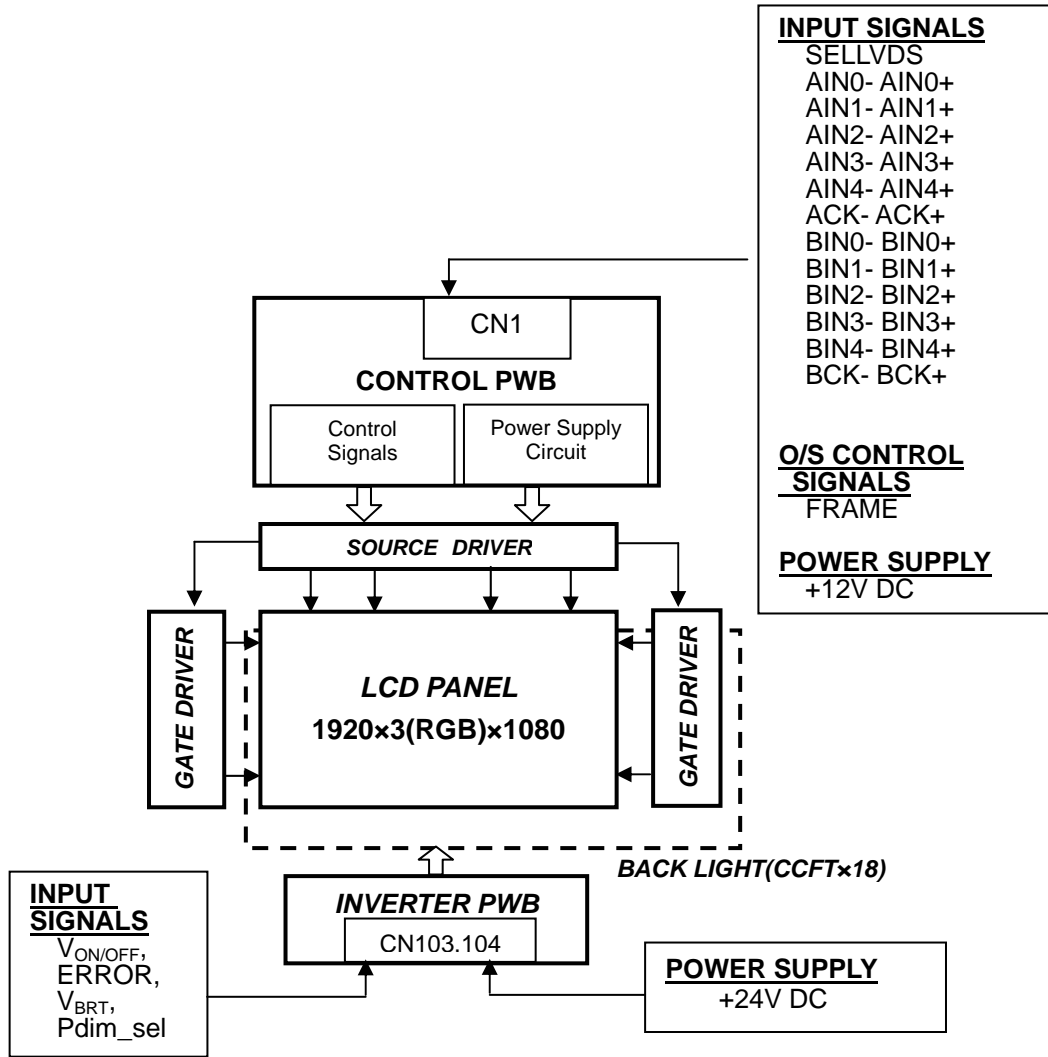



## 4.3. Backlight driving

CN103 (+24V DC power supply and inverter control)

Using connector: S14B-PHA-SM-TB (LF) (SN)

Matching connector: PHAR-14 /PHR-14(JST) or equivalent connector

Pin No.	Symbol	Function	Default(OPEN)	Input Impedance	Remark
1	V <sub>INV</sub>	+24V	-		
2	V <sub>INV</sub>	+24V	-		
3	V <sub>INV</sub>	+24V	-		
4	V <sub>INV</sub>	+24V	-		
5	V <sub>INV</sub>	+24V	-		
6	GND		-		
7	GND		-		
8	GND		-		
9	GND		-		
10	GND		-		
11	ERROR	ERROR DETECT	Normal : LOW, Fail : Open collector		
12	V <sub>ON/OFF</sub>	Inverter ON/OFF	Inverter OFF	75kohm	[Note 1]
13	V <sub>BRT</sub>	Brightness Control	3.3V : pull up Duty(Brightness) 100%	600kohm	[Note 3]
14	Pdim_sel	Brightness Control Selection	3.3V : pull up Selected Analog PWM	67kohm	[Note 2]

\*GND of an inverter board is not connected to GND of a module chassis and a liquid crystal panel drive part.

CN104(+24V DC power supply)

Using connector: S14B-PHA-SM-TB (LF) (SN)

Matching connector: PHAR-14/PHR-14 (JST) or equivalent connector

Pin No.	Symbol	Function	Default (OPEN)	Input Impedance	Remark
1	V <sub>INV</sub>	+24V	-		
2	V <sub>INV</sub>	+24V	-		
3	V <sub>INV</sub>	+24V	-		
4	V <sub>INV</sub>	+24V	-		
5	V <sub>INV</sub>	+24V	-		
6	GND		-		
7	GND		-		
8	GND		-		
9	GND		-		
10	GND		-		
11	Reserved	For LCD module internal usage, should be open			
12	Reserved	For LCD module internal usage, should be open			
13	Reserved	For LCD module internal usage, should be open			
14	Reserved	For LCD module internal usage, should be open			

[Note 1] Inverter ON/OFF

Input voltage	Function
0V	Inverter : OFF
3.3V	Inverter : ON

[Note 2] Brightness Control Selection

Pin No.14 is used for the selection of dimming control for V<sub>BRT</sub> pin (Pin No.13).

Input voltage	V <sub>BRT</sub>
0V	Pulse dimming
3.3V	Analog dimming

[Note 3] Brightness Control

1. Analog Dimming

Brightness control is regulated by analog input voltage (0V to 3.15V).

T<sub>a</sub>=25°C

		MIN	TYP	MAX	Function
Input voltage (V <sub>BRT</sub> )	[V]	0V	<->	3.15V	PMW frequency : 110 ± 10Hz 0V: Dark - 3.15V: Bright
[Reference] Brightness ratio	[ % ]	6	<->	100	

2. Pulse Dimming

Pin No.13 is used for the control of the PWM duty with input pulse from 95Hz to 350Hz.

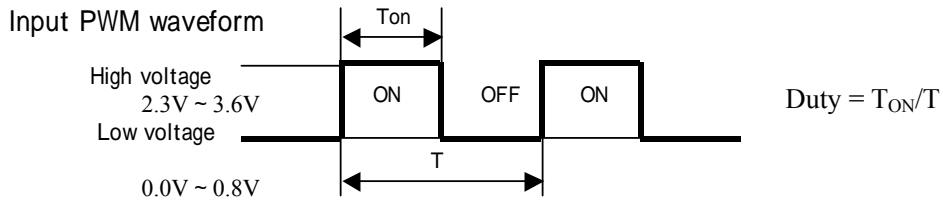

		MIN	TYP	MAX	Remark
Pulse signal	[Hz]	95	110	350	V <sub>inv</sub> =24V T <sub>a</sub> =25°C Pulse signal=100Hz/120Hz
DUTY(T <sub>ON</sub> /T)	[%]	15	<->	100	
Dimming level (Brightness ratio)	[%]	6	<->	100	

[Note] In case of using Pulse Dimming, be careful so that the V<sub>BRT</sub> signal (Pin 13) doesn't have glitch.

#### 4.4. The back light system characteristics

The back light system is direct type with 18 CCFTs (Cold Cathode Fluorescent Tube).

The characteristics of the lamp are shown in the following table. The value mentioned below is at the case of one CCFT.

Item	Symbol	Min.	Typ.	Max.	Unit	Remarks
Life time	T <sub>L</sub>	-	60000	-	Hour	[Note]

[Note]

- Lamp life time is defined as the time when brightness becomes 50% of the original value in the continuous operation under the condition of Ta=25°C and brightness control(V<sub>BRT</sub>=100%).
- Above value is applicable when the long side of LCD module is placed horizontally (Landscape position). (Lamp lifetime may vary if LCD module is in portrait position due to the change of mercury density inside the lamp.)

## 5. Absolute Maximum Ratings

Parameter	Symbol	Condition	Ratings	Unit	Remark
Input voltage (for Control)	V <sub>I</sub>	Ta=25°C	-0.3 ~ 3.6	V	[Note 1]
12V supply voltage (for Control)	V <sub>CC</sub>	Ta=25°C	0 ~ +14	V	
Input voltage (for Inverter)	V <sub>ON</sub> V <sub>BRT</sub>	Ta=25°C	0 ~ +6	V	
24V supply voltage (for Inverter)	V <sub>INV</sub>	Ta=25°C	0 ~ +29	V	
Storage temperature	T <sub>stg</sub>	-	-25 ~ +60	°C	[Note 2]
Operation temperature (Ambient)	T <sub>opa</sub>	-	0 ~ +50	°C	

[Note 1] SELLVDS, FRAME

[Note 2] Humidity 95%RH Max.(Ta≤40°C)

Maximum wet-bulb temperature at 39°C or less.(Ta>40°C)

No condensation.

6. Electrical Characteristics

6.1. Control circuit driving

Ta=25°C

Parameter		Symbol	Min.	Typ.	Max.	Unit	Remark
+12V supply voltage	Supply voltage	Vcc	11.4	12	12.6	V	[Note 1]
	Current dissipation	Icc	-	0.7	2.0	A	[Note 2]
	Inrush current	IRUSH	-	5.0	-	A	[Note 7]
Permissible input ripple voltage		VRP	-	-	100	mV <sub>P-P</sub>	Vcc = +12.0V
Differential input threshold voltage	High	VTH	-	-	100	mV	V <sub>CM</sub> = +1.2V [Note 6]
	Low	VTL	-100	-	-	mV	
Input Low voltage		VIL	0	-	1.0	V	[Note 3]
Input High voltage		VIH	2.3	-	3.3	V	
Input leak current (Low)		IIL1	-	-	400	μA	V <sub>I</sub> = 0V [Note 4]
		IIL2	-	-	100	μA	V <sub>I</sub> = 0V [Note 5]
Input leak current (High)		IIH1	-	-	100	μA	V <sub>I</sub> = 3.3V [Note 4]
		IIH2	-	-	400	μA	V <sub>I</sub> = 3.3V [Note 5]
Terminal resistor		RT	-	100	-	Ω	Differential input

[Note]V<sub>CM</sub>: Common mode voltage of LVDS driver.

[Note 1]

Input voltage sequences

- 0 < t1 ≤ 20ms
- 10 < t2 ≤ 50ms
- 10 < t3 ≤ 50ms
- 0 < t4 ≤ 1s
- t5 ≥ 300ms
- t6 ≥ 0
- t7 ≥ 300ms

Dip conditions for supply voltage

- a) 6.5V ≤ Vcc < 10.8V
- td ≤ 10ms
- b) Vcc < 6.5V

Dip conditions for supply voltage is based on input voltage sequence.

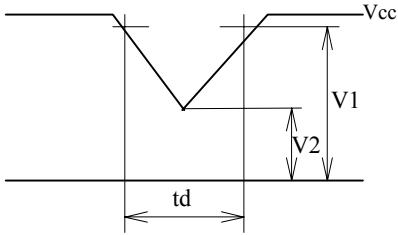
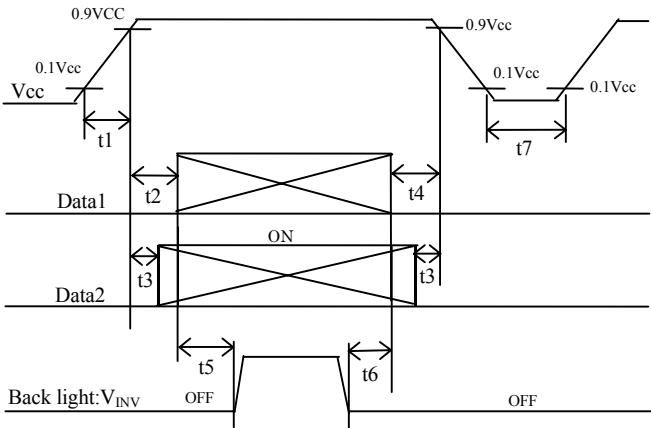

V1:10.8V  
V2:6.5V

Data1: ACK±, AIN0±, AIN1±, AIN2±, AIN3±, AIN4±, BCK±, BIN0±, BIN1±, BIN2±, BIN3±, BIN4±  
 \*V<sub>CM</sub> voltage pursues the sequence mentioned above  
 Data2: SELLVDS, FRAME

[Note] About the relation between data input and back light lighting, please base on the above-mentioned input sequence. When back light is switched on before panel operation or after a panel operation stop, it may not display normally. But this phenomenon is not based on change of an incoming signal, and does not give damage to a liquid crystal display.

[Note 2] Typical current situation: 1023 gray-bar patterns. (Vcc = +12.0V)

The explanation of RGB gray scale is seen in section 8.

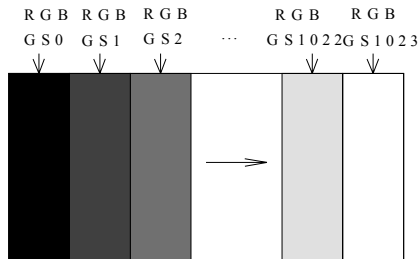

Vcc = +12.0V  
 CK = 74.25MHz  
 Th = 14.8μs

[Note 3] SELLVDS, FRAME

[Note 4] SELLVDS

[Note 5] FRAME

[Note 6] ACK±, AIN0±, AIN1±, AIN2±, AIN3±, AIN4±, BCK±, BIN0±, BIN1±, BIN2±, BIN3±, BIN4±

[Note 7] Vcc12V inrush current waveform

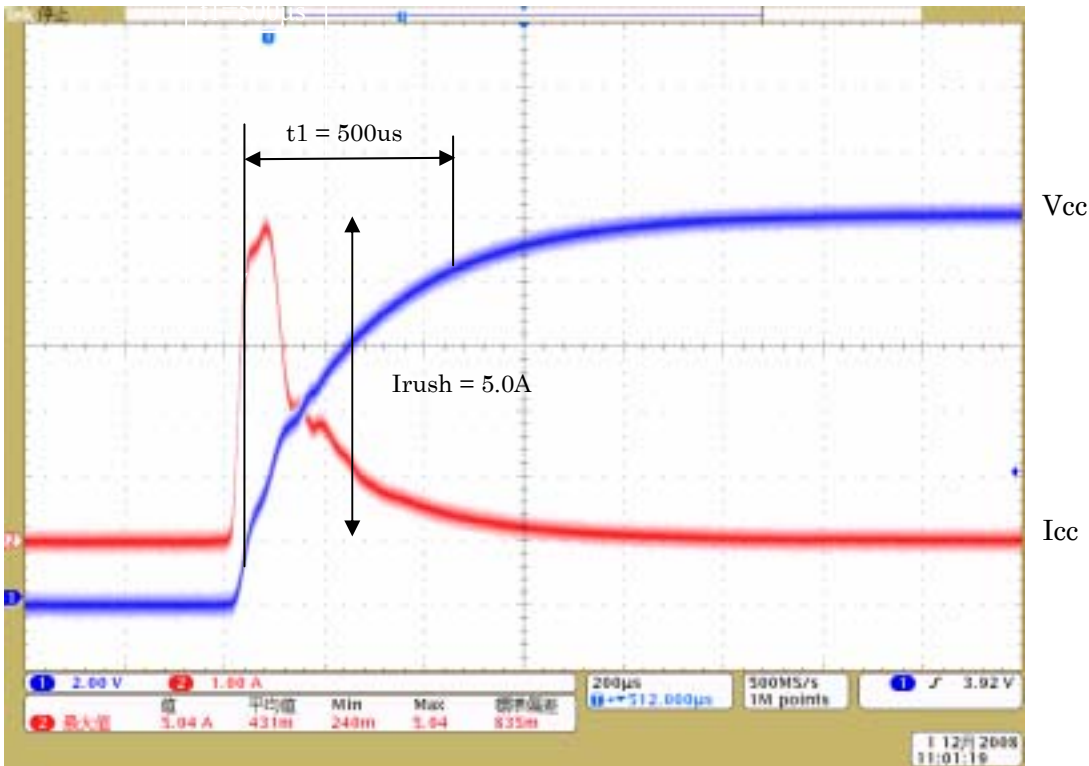

6.2. Inverter driving for back light

The back light system is direct type with 18 CCFTs (Cold Cathode Fluorescent Tube).

Parameter	Symbol	Min.	Typ.	Max.	Unit	Remark	
+ 24V	Current dissipation 1	I <sub>INV 1</sub>	-	8.5	9.2	A	V <sub>INV</sub> = 24V, Ta = 25°C DUTY = 100% [Note 1,2]
	Current dissipation 2	I <sub>INV 2</sub>	-	7.5	8.2	A	
	Supply voltage	V <sub>INV</sub>	22.8	24.0	25.2	V	
Permissible input ripple voltage	V <sub>RF</sub>	-	-	300	mV <sub>p-p</sub>	V <sub>INV</sub> = +24.0V	
Input voltage (Low)	V <sub>ONL</sub>	0	-	0.8	V	V <sub>ON/OFF</sub> , V <sub>BRT</sub> , Pdim_sel	
Input voltage (High)	V <sub>ONH</sub>	2.3	-	3.6	V		

[Note 1] 1) V<sub>INV</sub> turn-on condition

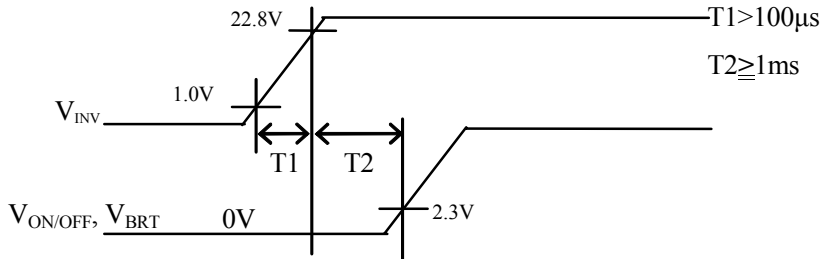

2) V<sub>INV</sub>-turn-off condition

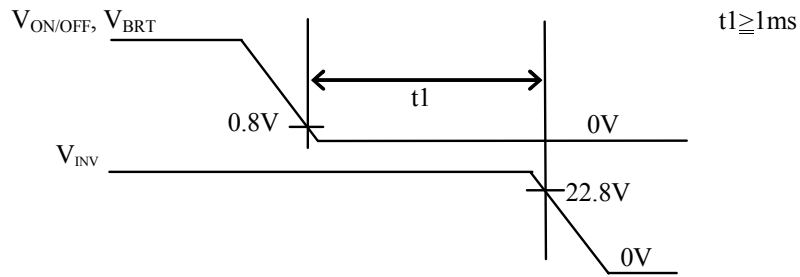

[Note 2] Current dissipation 1 : Definition within 60 minutes after turn on. (Rush current is excluded.)

Current dissipation 2 : Definition more than 60 minutes after turn on.

## 7. Timing characteristics of input signals

### 7.1. Timing characteristics

Timing diagrams of input signal are shown in Fig.2.

Parameter		Symbol	Min.	Typ.	Max.	Unit	Remark
Clock	Frequency	1/Tc	69	74.25	76	MHz	
Data enable signal	Horizontal period	TH	1084	1100	1200	clock	
			14.6	14.8	16.1	μs	
	Horizontal period (High)	THd	960	960	960	clock	
	Vertical period	TV	1109	1125	1400	line	
Vertical period (High)	TVd	1080	1080	1080	line		

[Note]-Please turn off the module after it shows the black screen.

-Please make sure that length of vertical period should become of an integral multiple of horizontal length of period. Otherwise, the screen may not display properly.

-As for your final setting of driving timing, we will conduct operation check test at our side, please inform your final setting.

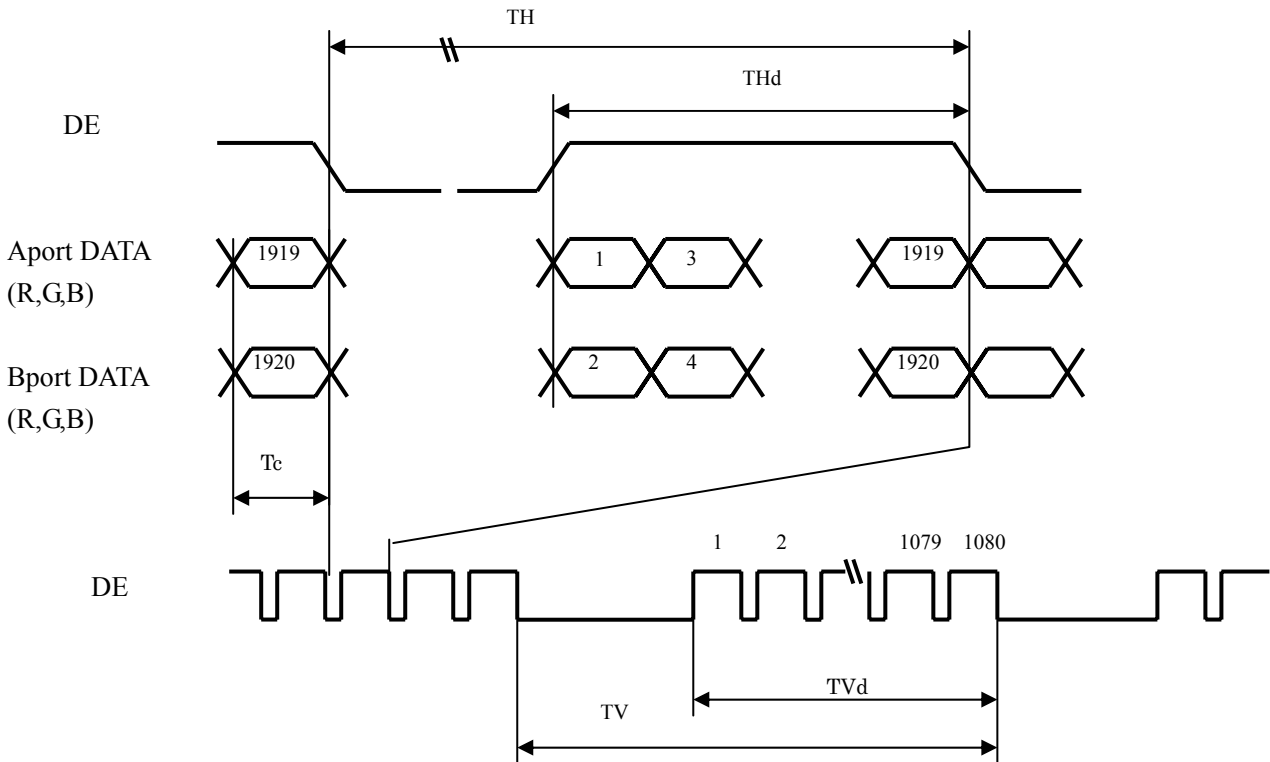
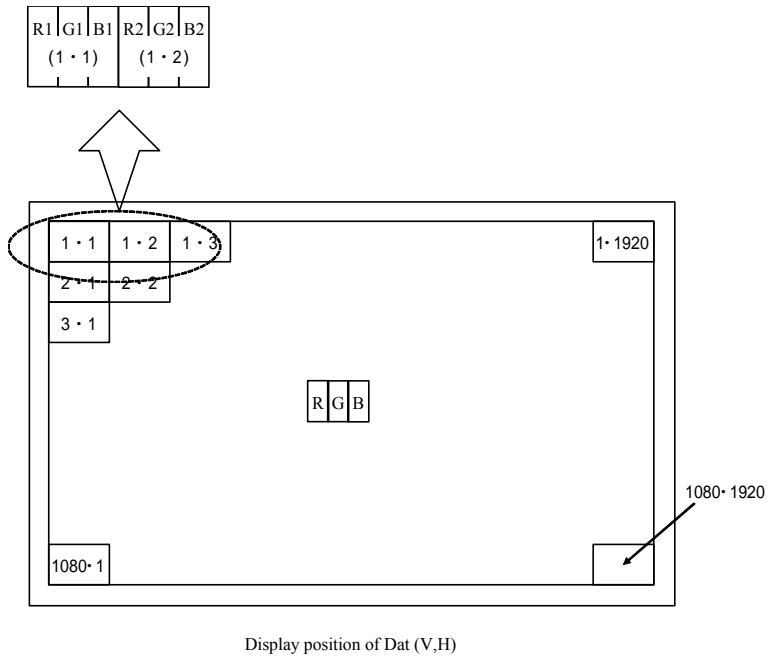

Fig.2 Timing characteristics of input signals

## 7.2. Input data signal and display position on the screen





Input Signal, Basic Display Colors and Gray Scale of Each Color

Colors & Gray scale	Data signal																														
	Gray Scale	R0	R1	R2	R3	R4	R5	R6	R7	R8	R9	G0	G1	G2	G3	G4	G5	G6	G7	G8	G9	B0	B1	B2	B3	B4	B5	B6	B7	B8	B9
Basic Color	Black	-	0	0	0	0	0	0	0	0	0	0	0	0	0	0	0	0	0	0	0	0	0	0	0	0	0	0	0	0	0
	Blue	-	0	0	0	0	0	0	0	0	0	0	0	0	0	0	0	0	0	0	0	1	1	1	1	1	1	1	1	1	1
	Green	-	0	0	0	0	0	0	0	0	0	1	1	1	1	1	1	1	1	1	1	0	0	0	0	0	0	0	0	0	0
	Cyan	-	0	0	0	0	0	0	0	0	0	1	1	1	1	1	1	1	1	1	1	1	1	1	1	1	1	1	1	1	1
	Red	-	1	1	1	1	1	1	1	1	1	0	0	0	0	0	0	0	0	0	0	0	0	0	0	0	0	0	0	0	0
	Magenta	-	1	1	1	1	1	1	1	1	1	0	0	0	0	0	0	0	0	0	0	1	1	1	1	1	1	1	1	1	1
	Yellow	-	1	1	1	1	1	1	1	1	1	1	1	1	1	1	1	1	1	1	1	0	0	0	0	0	0	0	0	0	0
	White	-	1	1	1	1	1	1	1	1	1	1	1	1	1	1	1	1	1	1	1	1	1	1	1	1	1	1	1	1	1
Gray Scale of Red	Black	GS0	0	0	0	0	0	0	0	0	0	0	0	0	0	0	0	0	0	0	0	0	0	0	0	0	0	0	0	0	
	↑	GS1	1	0	0	0	0	0	0	0	0	0	0	0	0	0	0	0	0	0	0	0	0	0	0	0	0	0	0	0	
	Darker	GS2	0	1	0	0	0	0	0	0	0	0	0	0	0	0	0	0	0	0	0	0	0	0	0	0	0	0	0	0	
	↑	↓																													
	↓	↓																													
	Brighter	GS1021	1	0	1	1	1	1	1	1	0	0	0	0	0	0	0	0	0	0	0	0	0	0	0	0	0	0	0	0	
	↓	GS1022	0	1	1	1	1	1	1	1	0	0	0	0	0	0	0	0	0	0	0	0	0	0	0	0	0	0	0	0	
	Red	GS1023	1	1	1	1	1	1	1	1	0	0	0	0	0	0	0	0	0	0	0	0	0	0	0	0	0	0	0	0	
Gray Scale of Green	Black	GS0	0	0	0	0	0	0	0	0	0	0	0	0	0	0	0	0	0	0	0	0	0	0	0	0	0	0	0		
	↑	GS1	0	0	0	0	0	0	0	1	0	0	0	0	0	0	0	0	0	0	0	0	0	0	0	0	0	0	0		
	Darker	GS2	0	0	0	0	0	0	0	0	1	0	0	0	0	0	0	0	0	0	0	0	0	0	0	0	0	0	0		
	↑	↓																													
	↓	↓																													
	Brighter	GS1021	0	0	0	0	0	0	0	1	0	1	1	1	1	1	1	1	1	0	0	0	0	0	0	0	0	0	0		
	↓	GS1022	0	0	0	0	0	0	0	0	1	1	1	1	1	1	1	1	1	0	0	0	0	0	0	0	0	0	0		
	Green	GS1023	0	0	0	0	0	0	0	1	1	1	1	1	1	1	1	1	1	0	0	0	0	0	0	0	0	0	0		
Gray Scale of Blue	Black	GS0	0	0	0	0	0	0	0	0	0	0	0	0	0	0	0	0	0	0	0	0	0	0	0	0	0	0			
	↑	GS1	0	0	0	0	0	0	0	0	0	0	0	0	0	0	0	0	1	0	0	0	0	0	0	0	0	0			
	Darker	GS2	0	0	0	0	0	0	0	0	0	0	0	0	0	0	0	0	0	1	0	0	0	0	0	0	0	0			
	↑	↓																													
	↓	↓																													
	Brighter	GS1021	0	0	0	0	0	0	0	0	0	0	0	0	0	0	0	0	1	0	1	1	1	1	1	1	1	1			
	↓	GS1022	0	0	0	0	0	0	0	0	0	0	0	0	0	0	0	0	0	1	1	1	1	1	1	1	1	1			
	Blue	GS1023	0	0	0	0	0	0	0	0	0	0	0	0	0	0	0	0	1	1	1	1	1	1	1	1	1	1			

0: Low level voltage, 1: High level voltage.

Each basic color can be displayed in 1024 gray scales from 10 bits data signals. According to the combination of total 30 bits data signals, the one billion colors display can be achieved on the screen.

8. Optical characteristics

Ta=25°C, V<sub>CC</sub>=12.0V, V<sub>INV</sub>=24.0V, V<sub>BRT</sub>=100%, Timing:60Hz (typ. value)

Parameter		Symbol	Condition	Min.	Typ.	Max.	Unit	Remark
Viewing angle range	Horizontal	$\theta_{21}$ $\theta_{22}$	CR <sub>≥</sub> 10	70	88	-	Deg.	[Note1,4]
	Vertical	$\theta_{11}$ $\theta_{12}$		70	88	-	Deg.	
Contrast ratio		CR <sub>n</sub>	$\theta=0$ deg.	2000	3000	-		[Note2,4]
Response time		$\tau_{rd}$		-	6	12	ms	[Note3,4,5]
Chromaticity	White	x		0.248	0.278	0.308	-	[Note4]
		y		0.255	0.285	0.315	-	
	Red	x		0.612	0.642	0.672	-	
		y		0.314	0.344	0.374	-	
	Green	x		0.251	0.281	0.311	-	
		y		0.575	0.605	0.635	-	
	Blue	x		0.113	0.143	0.173	-	
		y		0.043	0.073	0.103	-	
Luminance	White	Y <sub>L</sub>	400	500	-	cd/m <sup>2</sup>		
Luminance uniformity	White	$\delta w$	-	-	1.25	-	[Note 6]	

Measurement condition: Set the value of V<sub>BRT</sub> to maximum luminance of white.

\*The measurement shall be executed 60 minutes after lighting at rating.

[Note]The optical characteristics are measured using the following equipment.

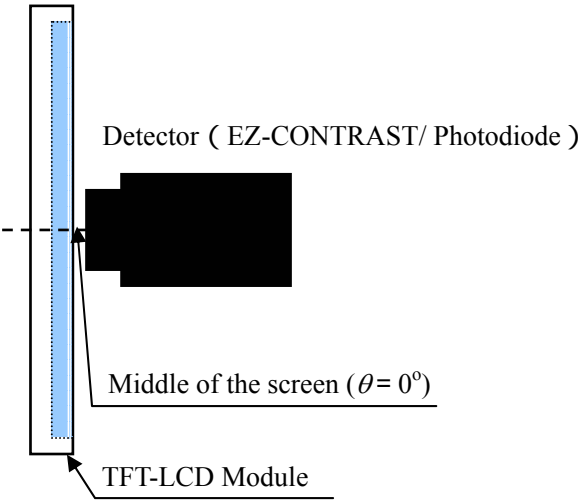

Fig.3-1 Measurement of viewing angle range and Response time.

Viewing angle range: EZ-CONTRAST  
Response time: Photodiode

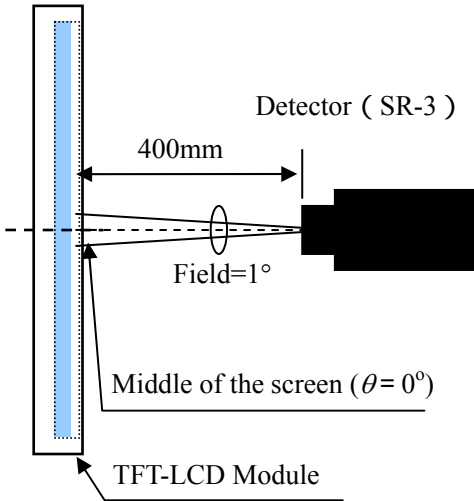
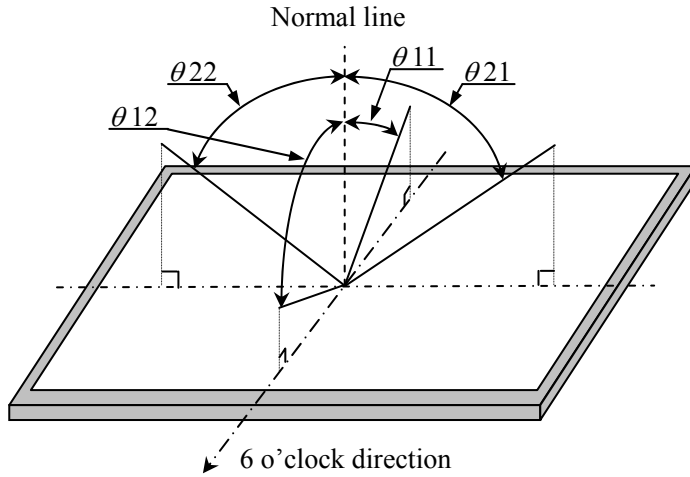

Fig.3-2 Measurement of Contrast, Luminance, Chromaticity.

[Note 1] Definitions of viewing angle range :



[Note 2] Definition of contrast ratio :

The contrast ratio is defined as the following.

$$\text{Contrast Ratio} = \frac{\text{Luminance (brightness) with all pixels white}}{\text{Luminance (brightness) with all pixels black}}$$

[Note 3] Definition of response time

The response time ( $\tau_{rd}$ ) is defined as the following figure and shall be measured by switching the input signal for “any level of gray (0%, 25%, 50%, 75% and 100%)” and “any level of gray (0%, 25%, 50%, 75% and 100%)”.

	0%	25%	50%	75%	100%
0%		tr:0%-25%	tr:0%-50%	tr:0%-75%	tr:0%-100%
25%	td: 25%-0%		tr: 25%-50%	tr:25%-75%	tr: 25%-100%
50%	td: 50%-0%	td: 50%-25%		tr: 50%-75%	tr: 50%-100%
75%	td: 75%-0%	td: 75%-25%	td: 75%-50%		tr: 75%-100%
100%	td: 100%-0%	td: 100%-25%	td: 100%-50%	td:100%-75%	

t\*:x-y : response time from level of gray(x) to level of gray(y)

$$\tau_{rd} = \sum(\text{tr} \cdot \text{d}:x-y)/20$$

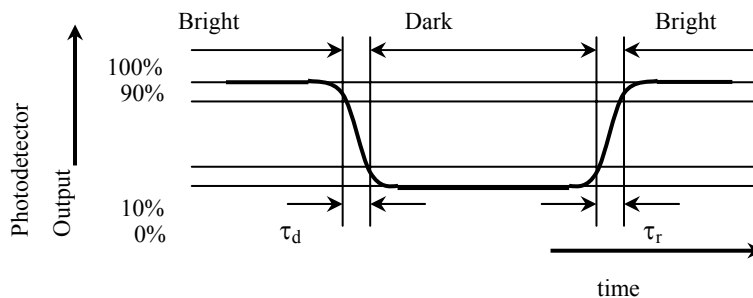

[Note 4] This shall be measured at center of the screen.

[Note 5] This value is valid when O/S driving is used at typical input time value.

[Note 6] Definition of white uniformity ;

White uniformity is defined as the following with five measurements. (A~E)

$$\delta w = \frac{\text{Maximum luminance of five points (brightness)}}{\text{Minimum luminance of five points (brightness)}}$$

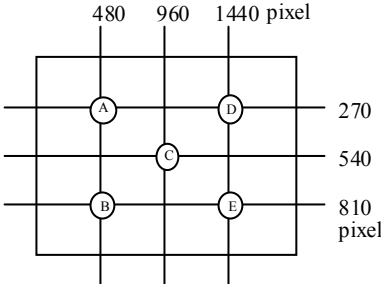

9. Handling Precautions of the module

- a) Be sure to turn off the power supply when inserting or disconnecting the cable.
- b) This product is using the parts (inverter, CCFT etc), which generate the high voltage. Therefore, during operating, please don't touch these parts.
- c) Brightness control voltage is switched for "ON" and "OFF", as shown in Fig.4. Voltage difference generated by this switching,  $V_{INV}$ , may affect a sound output, etc. when the power supply is shared between the inverter and its surrounding circuit. So, separate the power supply of the inverter circuit with the one of its surrounding circuit.

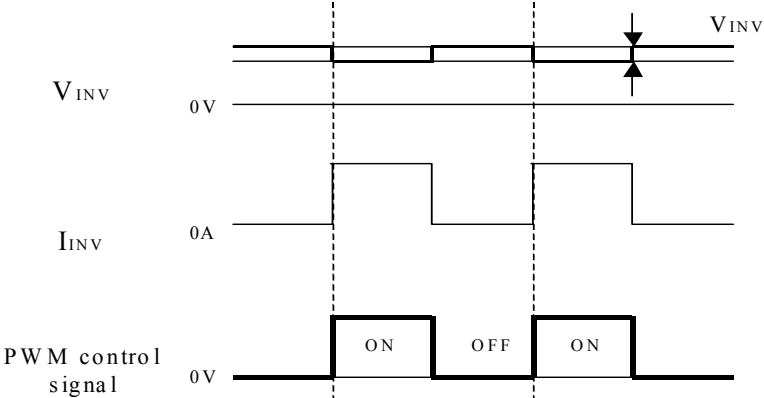

Fig.4 Brightness control voltage.

\*Since inverter board's GND is not connected to the frame of the LCD module, please connect it with the Customer's GND of inverter power supply.

- d) Be sure to design the cabinet so that the module can be installed without any extra stress such as warp or twist.
- e) Since the front polarizer is easily damaged, pay attention not to scratch it.
- f) Since long contact with water may cause discoloration or spots, wipe off water drop immediately.
- g) When the panel surface is soiled, wipe it with absorbent cotton or other soft cloth.
- h) Since the panel is made of glass, it may break or crack if dropped or bumped on hard surface. Handle with care.
- i) Since CMOS LSI is used in This LCD module, take care of static electricity and take the human earth into consideration when handling.
- j) This LCD module has some printed circuit boards (PCBs) on the back side, take care to keep them form any stress or pressure when handling or installing the module; otherwise some of electronic parts on the PCBs may be damaged.
- k) Observe all other precautionary requirements in handling components.

- l) When some pressure is added onto the module from rear side constantly, it causes display non-uniformity issue, functional defect, etc. So, please avoid such design.
- m) When giving a touch to the panel at power on supply, it may cause some kinds of degradation. In that case, once turn off the power supply, and turn on after several seconds again, and that is disappear.
- n) When handling LCD modules and assembling them into cabinets, please be noted that long-term storage in the environment of oxidization or deoxidization gas and the use of such materials as reagent, solvent, adhesive, resin, etc. which generate these gasses, may cause corrosion and discoloration of the LCD modules.
- o) This LCD module is designed to prevent dust from entering into it. However, there would be a possibility to have a bad effect on display performance in case of having dust inside of LCD module.
- p) This LCD module pass over the rust.

## 10. Packing form

- a) Piling number of cartons : 2 maximum
- b) Packing quantity in one carton : 8 pcs.
- c) Carton size : 1190(W) × 1160 (D) × 870(H) [mm]
- d) Total mass of one carton filled with full modules : 120 kg (typ.)

Packing form are shown in Fig.5

## 11. Reliability test item

No.	Test item	Condition
1	High temperature storage test	Ta=60°C 240h
2	Low temperature storage test	Ta=-25°C 240h
3	High temperature and high humidity operation test	Ta=40°C 95%RH 240h (No condensation)
4	High temperature operation test	Ta=50°C 240h
5	Low temperature operation test	Ta=0°C 240h
6	Vibration test (non-operation)	Frequency : 10~57Hz/Vibration width (one side): 0.075mm : 58~500Hz/Acceleration: 9.8 m/s <sup>2</sup> Sweep time: 11 minutes Test period: 3 hours (1h for each direction of X, Y, Z)
7	Shock test (non-operation)	Maximum acceleration: 294m/s <sup>2</sup> Pulse width : 11ms, sinusoidal half wave Direction: +/-X, +/-Y, +/-Z, once for each direction.
8	ESD	* At the following conditions, it is a thing without incorrect operation and destruction. (1)Non-operation : Contact electric discharge ±10kV Non-contact electric discharge ±20kV (2)Operation : Contact electric discharge ±8kV Non-contact electric discharge ±15kV Conditions: 150pF, 330ohm

[Result evaluation criteria]

Under the display quality test condition with normal operation state, there shall be no change, which may affect practical display function.

[Note]

These items apply to the single module.

12. Others

1) Lot No. Label ;

The label that displays SHARP, product model (LK460D3LA28), a product number is stuck on the back of the module.



How to express Lot No.

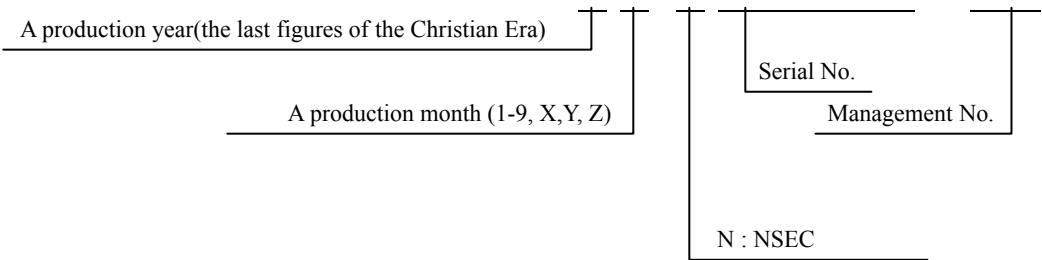

2) Packing Label

[LK460D3LA29X] NSEC PRODUCTION

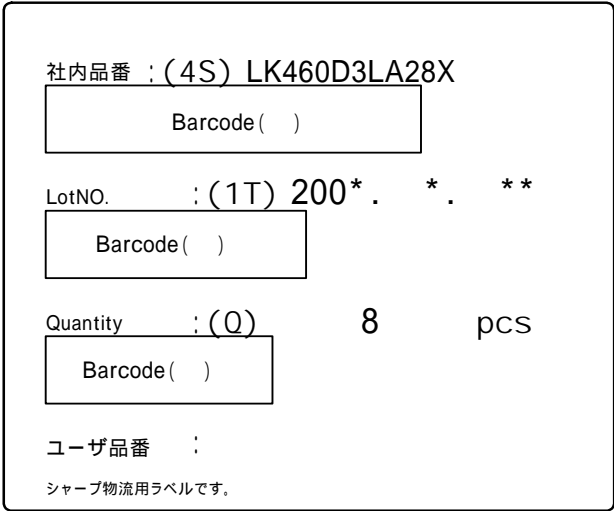

Management No.  
Lot No. (Date)  
Quantity

- 3) Adjusting volume has been set optimally before shipment, so do not change any adjusted value. If adjusted value is changed, the specification may not be satisfied.
- 4) Disassembling the module can cause permanent damage and should be strictly avoided.
- 5) Please be careful since image retention may occur when a fixed pattern is displayed for a long time.
- 6) The chemical compound, which causes the destruction of ozone layer, is not being used.

- 7) Cold cathode fluorescent lamp in LCD PANEL contains a small amount of mercury. Please follow local ordinances or regulations for disposal. This sentence is displayed on the backside of the module.

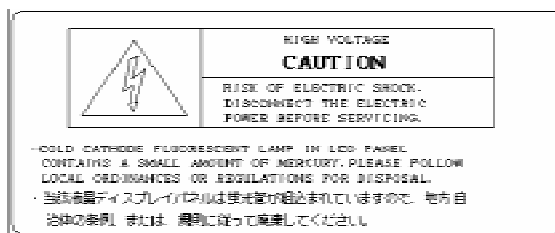

- 8) This LCD is appropriate to UL. Below figure shows the UL label.

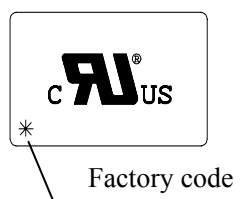

- 9) When any question or issue occurs, it shall be solved by mutual discussion.

- 10) This LCD module is corresponded to RoHS.

RoHS marking is on the carton front side.

### 13. Carton storage condition

Temperature	0°C to 40°C
Humidity	95%RH or less
Reference condition	: 20°C to 35°C, 85%RH or less (summer) : 5°C to 15°C, 85%RH or less (winter) • the total storage time (40°C,95%RH) : 240H or less
Sunlight	Be sure to shelter a product from the direct sunlight.
Atmosphere	Harmful gas, such as acid and alkali which bites electronic components and/or wires must not be detected.
Notes	Be sure to put cartons on palette or base, don't put it on floor, and store them with removing from wall Please take care of ventilation in storehouse and around cartons, and control changing temperature is within limits of natural environment
Storage life	1 year

# LD-K21505-22

NOTE:  
 1. UNSPECIFIED TOLERANCE TO BE  $\pm 1.7$   
 2. Maximum depth of mounting screws on emboss places  
 is 6.0mm.  
 3. Maximum torque on user holes is:  
 M5:12.0kgf.cm  
 M4:10.0kgf.cm

EMBOSSES FOR MOUNTING  
 HEIGHT=7.0 / 8PLACES

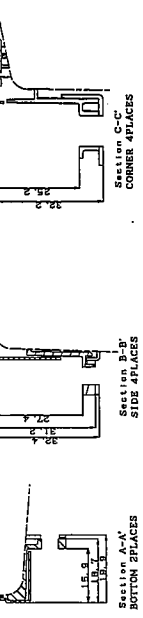
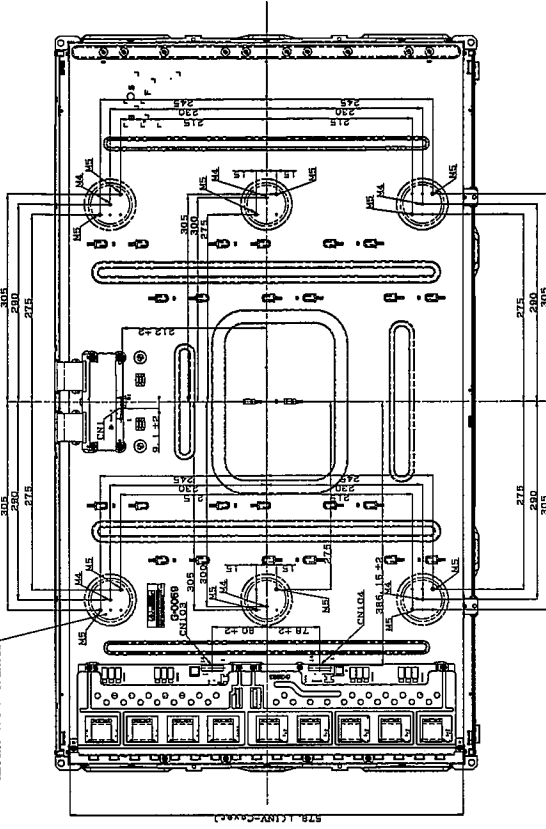
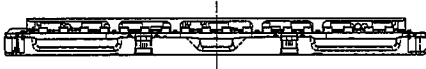
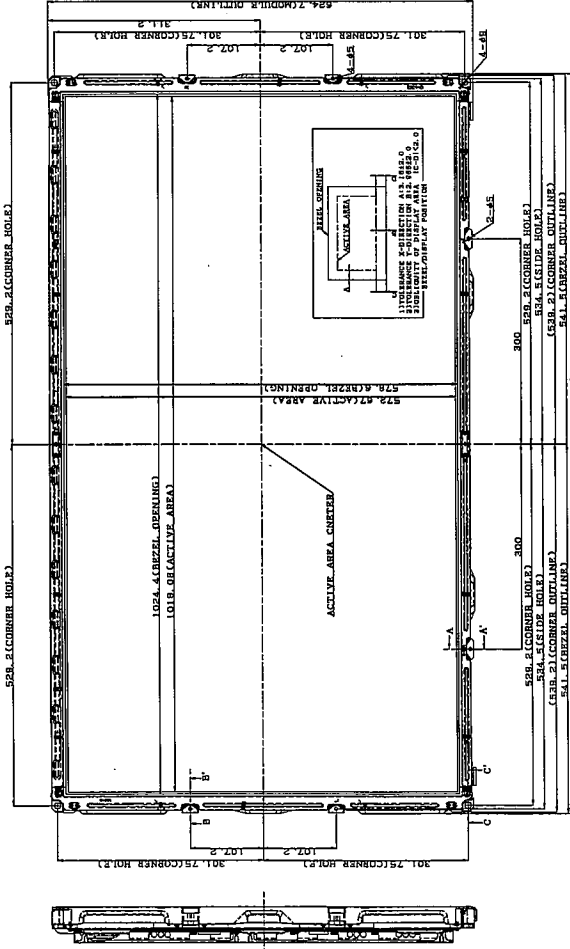
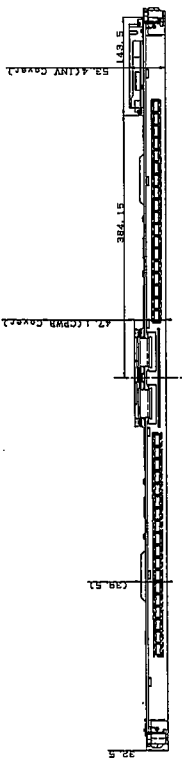
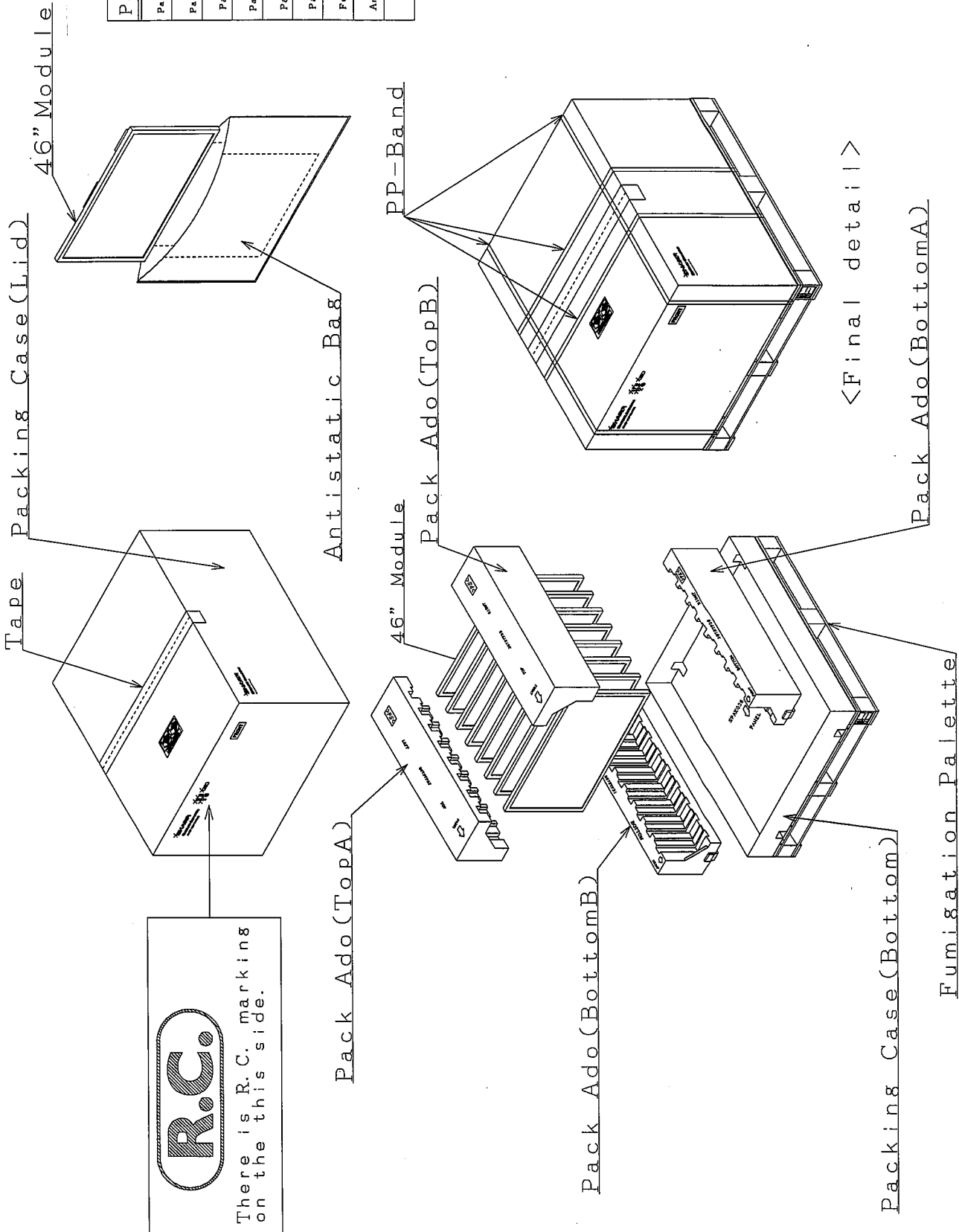

Fig. 1  
 TFT-LCD MODULE OUTLINE DIMENSIONS  
 LK460D3LA2x



# LD-K21505-23



Parts Name	Material
Packing Case (Bottom)	Cardboard
Packing Case (Lid)	Cardboard
Pack Ado (BottomA)	PS
Pack Ado (BottomB)	PS
Pack Ado (TopA)	PS
Pack Ado (TopB)	PS
Fumigation Palette	Fumigation wood
Antistatic Bag	PE (t=20μ)

**R.C.**  
 There is R. C. marking  
 on the this side.

Fig. 5 Module packing form

The reliability test form  
(Shock test & Vibration test)

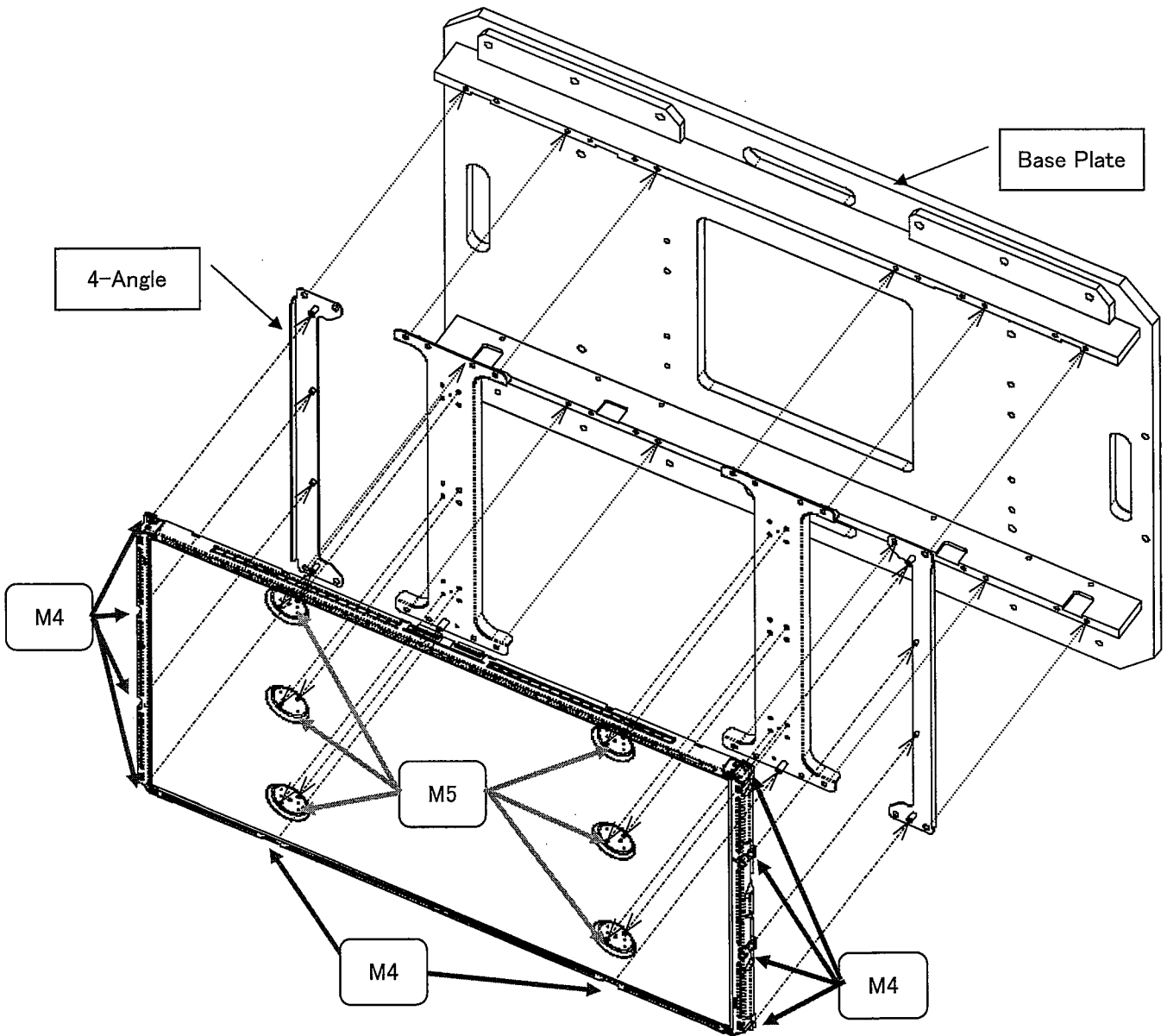

M5: 12 Places  
M4: 10 Places