



D4120P

Preliminary

NPN SILICON TRANSISTOR

MEDIUM VOLTAGE FAST-SWITCHING NPN TRANSISTOR

DESCRIPTION

The UTC **D4120P** is a medium voltage fast-switching NPN power transistor. It is characterized by medium breakdown voltage, high current capability, high switching speed and high reliability.

The UTC **D4120P** is intended to be used in energy-saving lights, electronic ballasts, a power transform or a common power amplifier, etc.

FEATURES

- * Medium breakdown voltage
- * High current capability
- * High switching speed
- * High reliability
- * RoHS-compliant product

EQUIVALENT CIRCUIT

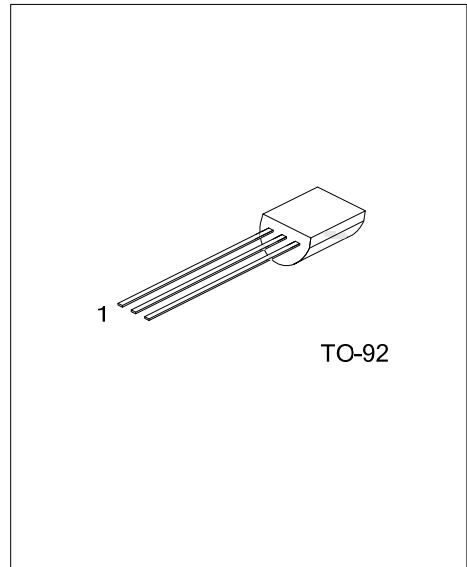
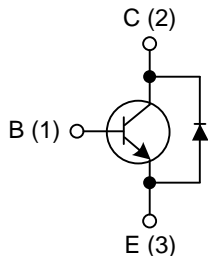

ORDERING INFORMATION

Ordering Number		Package	Pin Assignment			Packing
Lead Free	Halogen Free		1	2	3	
D4120PL-T92-B	D4120PG-T92-B	TO-92	B	C	E	Tape Box
D4120PL-T92-K	D4120PG-T92-K	TO-92	B	C	E	Bulk
D4120PL-T92-R	D4120PG-T92-R	TO-92	B	C	E	Tape Reel

<p>D4120PL-T92-B</p> <p>(1)Packing Type (2)Package Type (3)Halogen Free</p>	<p>(1) B: Tape Box, K: Bluk, R: Tape Reel (2) T92: TO-92 (3) Halogen Free, L: Lead Free</p>
---	---

■ ABSOLUTE MAXIMUM RATINGS ($T_C=25^\circ\text{C}$)

PARAMETER	SYMBOL	RATINGS	UNIT
Collector-Base Voltage	V_{CBO}	350	V
Collector-Emitter Voltage	V_{CEO}	200	V
Emitter-Base Voltage	V_{EBO}	7	V
Continuous Collector Current	I_C	1.5	A
Collector Power Dissipation	P_C	1	W
Junction Temperature	T_J	150	$^\circ\text{C}$
Storage Temperature	T_{STG}	-55~150	$^\circ\text{C}$

Note: Absolute maximum ratings are those values beyond which the device could be permanently damaged. Absolute maximum ratings are stress ratings only and functional device operation is not implied.

■ THERMAL DATA

PARAMETER	SYMBOL	RATINGS	UNIT
Junction to Ambient	θ_{JA}	125	$^\circ\text{C/W}$

■ ELECTRICAL CHARACTERISTICS ($T_C=25^\circ\text{C}$)

PARAMETER	SYMBOL	TEST CONDITIONS	MIN	TYP	MAX	UNIT
Collector-Emitter Sustaining Voltage	$V_{(BR)CEO}$	$I_C=10\text{mA}, I_B=0$	200			V
Collector -Base Breakdown Voltage	$V_{(BR)EBO}$	$I_C=1\text{mA}, I_E=0$	350			V
Collector -Base Breakdown Voltage	$V_{(BR)CBO}$	$I_C=0, I_E=1\text{mA}$	7			V
Collector Cut-Off Current	I_{CBO}	$V_{CB}=300\text{V}, I_E=0$			100	μA
Collect Emitter Cut-off Current	I_{CEO}	$V_{CE}=200\text{V}, I_B=0$			50	μA
Emitter Cut-Off Current	I_{EBO}	$V_{EB}=7\text{V}, I_C=0$			10	μA
Static Forward Current Transfer Ratio	$h_{FE(1)}$	$I_C=0.2\text{A}, V_{CE}=5\text{V}$	8		50	
	$h_{FE(2)}$	$I_C=1.5\text{A}, V_{CE}=5\text{V}$	5			
Collector-Emitter Saturation Voltage	$V_{CE(sat)(1)}$	$I_C=0.4\text{A}, I_B=0.1\text{A}$			0.5	V
	$V_{CE(sat)(2)}$	$I_C=1\text{A}, I_B=0.5\text{A}$			2	V
Base-Emitter Saturation Voltage	$V_{BE(sat)}$	$I_C=1\text{A}, I_B=0.25\text{A}$			1.5	V
Fall Time	t_f	$V_{CC}=24\text{V}, I_C=0.5\text{A}, I_{B1}=-I_{B2}=0.1\text{A}$			0.5	μS
Storage Time	T_{stg}	$V_{CC}=24\text{V}, I_C=0.5\text{A}, I_{B1}=-I_{B2}=0.1\text{A}$			4	μS
Input Resistance	f_T	$V_{CE}=10\text{V}, I_C=0.5\text{A},$	4			MHz

UTC assumes no responsibility for equipment failures that result from using products at values that exceed, even momentarily, rated values (such as maximum ratings, operating condition ranges, or other parameters) listed in products specifications of any and all UTC products described or contained herein. UTC products are not designed for use in life support appliances, devices or systems where malfunction of these products can be reasonably expected to result in personal injury. Reproduction in whole or in part is prohibited without the prior written consent of the copyright owner. The information presented in this document does not form part of any quotation or contract, is believed to be accurate and reliable and may be changed without notice.