

**COIL FORMERS**

**General data CP-P30/19 coil former**

PARAMETER	SPECIFICATION
Coil former material	polybutyleneterephthalate (PBT), glass reinforced, flame retardant in accordance with "UL 94V-0"; UL file number E45329 (R)
Maximum operating temperature	155 C, "IEC 60085", class F

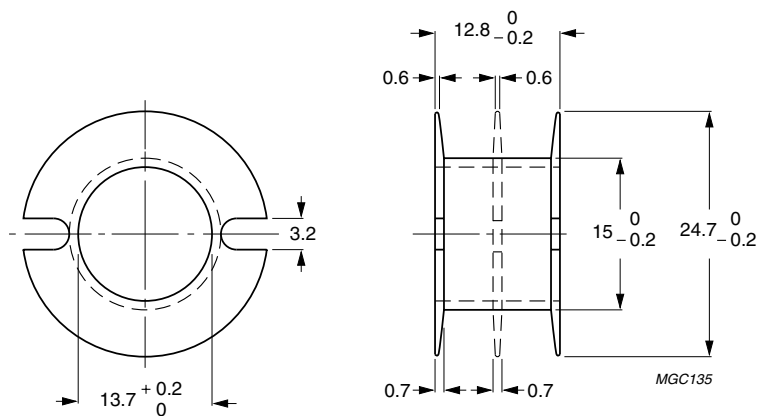

Dimensions in mm.

Fig.2 Coil former: CP-P30/19.

**Winding data for P30/19 coil former**

NUMBER OF SECTIONS	MINIMUM WINDING AREA (mm <sup>2</sup> )	NOMINAL WINDING WIDTH (mm)	AVERAGE LENGTH OF TURN (mm)	TYPE NUMBER
1	53.2	11.1	62	CP-P30/19-1S
2	2 24.9	2 5.15	62	CP-P30/19-2S
3	3 15.5	3 3.2	62	CP-P30/19-3S